

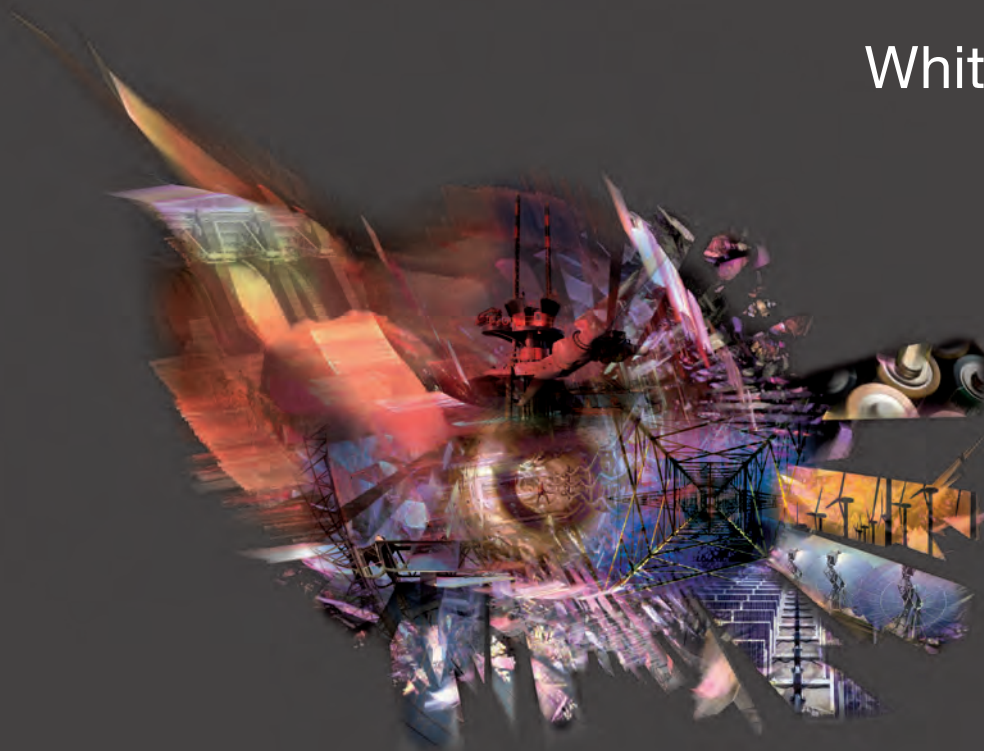

# **Grid integration of large-capacity Renewable Energy sources and use of large-capacity Electrical Energy Storage**

White paper



October 2012

The present White Paper is the third in a series whose purpose is to ensure that the IEC can continue to contribute with its standards and conformity assessment services to the solution of global problems in electrotechnology. The White Papers are developed by the IEC MSB (Market Strategy Board), responsible for analyzing and understanding the IEC's market so as to prepare the IEC strategically to face the future.

The proportion of renewable energies (RE) is called upon to increase in all major electricity markets. The reasons for this are not examined closely here, since they have been fully treated elsewhere. This paper explores what is needed to integrate large quantities of renewables into existing electricity grids, given various characteristics and difficulties which necessarily accompany such a change. Section 2 examines these characteristics, describes the difficulties and analyzes the consequent challenges for grid operators as well as for producers of electricity, both renewable and conventional.

Section 3 shows today's methods and responses to the challenges. These are extensive and applied widely and professionally; the section nevertheless concludes that they will not suffice as the proportion of renewables grows to 15 %, 25 % or even 35 % of the energy in some grids.

Thus section 4, one of the two core chapters of the paper, covers all the research, investment and other tools without which large-scale renewables cannot be successfully integrated. These range from what renewable generation needs to provide in order to be accepted, through all the control and infrastructure the grid itself needs in order to cope, to the realization

that *conventional* generation facilities also need to contribute significantly to make the whole exercise a success.

The second core part of the paper is section 5 on electrical energy storage (EES), and it extensively uses the results of the IEC White Paper on this subject published in 2011. It turns out that the various challenges and difficulties covered in section 2, and even more the avenues for the future sketched out in section 4, either depend on the use of storage or at least can benefit from it. Section 5 therefore outlines its use and usefulness for the integration of renewables and concludes – in harmony with the White Paper on storage – that significant developments are required in this area as well. The following section, section 6, briefly surveys the contribution that standards already make and can make in the future to solving the issues covered elsewhere.

Section 7 starts with a brief conclusion. Its thrust is that the electricity community knows in broad outline what will be needed to integrate large-scale renewables, but that many elements are not yet in place and much effort will be required. There follow recommendations addressed to the IEC's partners, in both the public and private sector, and to the IEC's own structures. The IEC MSB believes that future implementation of these recommendations is the factor which will constitute the greatest added value of the present White Paper.

*This White Paper was written by a project team under the MSB, in particular the experts of the State Grid Corporation of China (CN) and RASEI (the Renewable and Sustainable Energy Institute) in the University of Colorado at Boulder and NREL (US).*

<b>List of abbreviations</b>	<b>6</b>
<b>Section 1 Introduction</b>	<b>9</b>
<b>Section 2 RE generation: the present, the future and the integration challenges</b>	<b>13</b>
2.1 Drivers of RE development	14
2.1.1 Decarbonization	14
2.1.2 Energy security	15
2.1.3 Expanding energy access	16
2.2 Present status of RE generation and future projections	18
2.2.1 Wind energy	19
2.2.2 Solar energy	22
2.3 RE grid integration challenges	25
2.3.1 Non-controllable variability	28
2.3.2 Partial unpredictability	29
2.3.3 Locational dependency	30
<b>Section 3 Present: state of the art in integrating large-capacity RE</b>	<b>31</b>
3.1 General	32
3.2 RE generation technology	32
3.2.1 Wind power generation	32
3.2.2 PV power generation	38
3.2.3 Concentrated solar power generation	40
3.3 Transmission technology	43
3.3.1 AC transmission	43
3.3.2 VSC-HVDC transmission	45
3.4 Operational technologies and practices	46
3.4.1 Power forecasting	46
3.4.2 Operational practices	50
<b>Section 4 Future: technical solutions for integrating more large-capacity RE</b>	<b>57</b>
4.1 General	58
4.2 Grid-friendly RE generation	59
4.2.1 Need for grid-friendly RE generation	59

4.2.2	Advanced characteristics of RE generating units and plants	59
4.2.3	Centralized control of an RE plant cluster	61
4.2.4	Improvements in modelling RE generation	62
4.3	Improved flexibility in conventional generation	63
4.3.1	Need for more flexibility in conventional generation	63
4.3.2	Assessment of generation flexibility	63
4.3.3	Generation planning for both adequate capacity and adequate flexibility	65
4.4	Transmission expansion	67
4.4.1	Needs for transmission expansion	67
4.4.2	Application of new transmission technologies	67
4.4.3	Developments in transmission planning	72
4.5	Operational enhancement	74
4.5.1	Need for operational enhancement	74
4.5.2	More accurate RE power forecasts	75
4.5.3	Enhancement of operational tools and practices	76
4.6	Demand response	79
4.6.1	Demand response applications for RE integration	79
4.6.2	Demand response practices and trends	80
4.6.3	Technologies supporting more demand response	82
4.7	Summary	83
<b>Section 5 Application of large-capacity EES to support RE integration</b>		<b>85</b>
5.1	General	86
5.2	Promising large-capacity EES technologies	86
5.3	Roles of EES in RE integration	88
5.3.1	Grid-side roles of EES	88
5.3.2	Generation-side roles of EES	92
5.3.3	Demand-side roles of EES	95
5.4	Technology needs of large-capacity EES applications	96
5.5	Summary	98
<b>Section 6 Standards for large-capacity RE integration</b>		<b>99</b>
6.1	General	100
6.2	Present situation	100
6.3	Future needs	103

## **Section 7 Conclusions and recommendations 105**

---

7.1	Conclusions	106
7.2	Recommendations addressed to policy-makers and regulators	106
	Recommendation 7.2.1 – Coordinating all actors	107
	Recommendation 7.2.2 – Single framework for connecting and controlling renewables	107
	Recommendation 7.2.3 – Regulations to enable integration	107
7.3	Recommendations addressed to utilities, industry and research	107
	Recommendation 7.3.1 – Enhanced transmission as a precondition for renewables	107
	Recommendation 7.3.2 – Stochastic forecasting	107
	Recommendation 7.3.3 – Research for forecasting and complex modelling	108
	Recommendation 7.3.4 – Research for cluster connection and control	108
	Recommendation 7.3.5 – Research into EES	108
	Recommendation 7.3.6 – Forecasting the demand side	108
7.4	Recommendations addressed to the IEC and its committees	108
	Recommendation 7.4.1 – Technical contribution to the RE integration framework	108
	Recommendation 7.4.2 – Rapid progress in RE integration standards	108
	Recommendation 7.4.3 – Synergy with industry associations on RE integration	108

## **References 109**

---

**Technical and scientific terms**

<b>AC</b>	Alternating current
<b>AGC</b>	Automatic generation control
<b>AMI</b>	Advanced metering infrastructure
<b>BMS</b>	Battery management system
<b>CA</b>	Contingency analysis
<b>CAAGR</b>	Compound average annual growth rate
<b>CAES</b>	Compressed air energy storage
<b>CECRE</b>	(Spanish for) Renewable energy power control centre
<b>CSC-HVDC</b>	Current source converter HVDC
<b>CSP</b>	Concentrated solar power
<b>CSR</b>	Controllable shunt reactor
<b>DC</b>	Direct current
<b>DFIG</b>	Doubly fed induction generator
<b>DLC</b>	Double layer capacitor
<b>DR</b>	Demand response
<b>DSA</b>	Dynamic security analysis
<b>EEE</b>	Electrical energy efficiency
<b>EES</b>	Electrical energy storage
<b>ELCC</b>	Effective load carrying capacity
<b>EMS</b>	Energy management system
<b>EUE</b>	Expected unserved energy
<b>EV</b>	Electric vehicle
<b>EVPP</b>	Electric vehicle virtual power plant
<b>FACTS</b>	Flexible AC transmission system
<b>FES</b>	Flywheel energy storage
<b>FIT</b>	Feed-in tariff
<b>GEMAS</b>	(Spanish for) Maximum admissible wind power generation system
<b>GHG</b>	Greenhouse gas
<b>HVAC</b>	High voltage alternating current
<b>HVDC</b>	High voltage direct current
<b>IGBT</b>	Insulated gate bipolar transistor
<b>IRRE</b>	Insufficient ramping resource expectation
<b>LA</b>	Lead acid
<b>LCC-HVDC</b>	Line commutated converter HVDC
<b>LFP</b>	Lithium iron phosphate (LiFePO <sub>4</sub> )
<b>LFR</b>	Linear Fresnel reflector
<b>Li-ion</b>	Lithium ion
<b>LOLE</b>	Loss of load expectation
<b>LVRT</b>	Low voltage ride through
<b>MTDC</b>	Multi-terminal DC
<b>NaS</b>	Sodium sulphur
<b>NGCC</b>	Natural gas combined cycle

<b>NWP</b>	Numerical weather prediction
<b>PCS</b>	Power conversion system
<b>PHS</b>	Pumped hydro storage
<b>PIRP</b>	Participating intermittent resource program
<b>PV</b>	Photovoltaic
<b>RE</b>	Renewable energy/ies
<b>RFB</b>	Redox flow battery
<b>RMSE</b>	Root mean square error
<b>SCADA</b>	Supervisory control and data acquisition
<b>SCED</b>	Security constrained economic dispatch
<b>SCGT</b>	Simple cycle gas turbine
<b>SCIG</b>	Squirrel cage induction generator
<b>SMES</b>	Superconducting magnetic energy storage
<b>SNG</b>	Synthetic natural gas
<b>STATCOM</b>	Static synchronous compensator
<b>SVC</b>	Static var compensator
<b>TCSC</b>	Thyristor controlled series compensator
<b>TSA</b>	Transient stability analysis
<b>UC</b>	Unit commitment
<b>UHVAC</b>	Ultra-high voltage AC
<b>UHVDC</b>	Ultra-high voltage DC
<b>V2G</b>	Vehicle-to-grid
<b>VPP</b>	Virtual power plant
<b>VRFB</b>	Vanadium redox flow battery
<b>VSA</b>	Voltage stability analysis
<b>VSC-HVDC</b>	Voltage source converter HVDC
<b>WPP</b>	Wind power plant
<b>WRIG</b>	Wound rotor induction generator
<b>WSAT</b>	Wind security assessment tool
<b>WT</b>	Wind turbine
<b>WTG</b>	Wind turbine generator

### **Organizations, institutions and companies**

<b>AESO</b>	Alberta Electric System Operator
<b>AQSIQ</b>	Administration of Quality Supervision, Inspection and Quarantine (of China)
<b>BPA</b>	Bonneville Power Authority
<b>BCTC</b>	British Columbia Transmission Corporation
<b>CAB</b>	Conformity Assessment Board (of IEC)
<b>CAISO</b>	California Independent System Operator
<b>CanWEA</b>	Canadian Wind Energy Association
<b>CEPRI</b>	China Electric Power Research Institute
<b>CSPG</b>	China Southern Power Grid
<b>EPE</b>	Energy Research Corporation (of Brazil)

<b>EWEA</b>	European Wind Energy Association
<b>FERC</b>	Federal Energy Regulatory Commission (of US)
<b>GIVAR</b>	Grid Integration of Variable Renewables Project (of IEA)
<b>IEA</b>	International Energy Agency
<b>IEC</b>	International Electrotechnical Commission
<b>IEEE</b>	Institute of Electrical and Electronics Engineers
<b>IOU</b>	Investor-owned utility
<b>IPCC</b>	Intergovernmental Panel on Climate Change
<b>ISO</b>	International Organization for Standardization
<b>ISO</b>	Independent system operator
<b>IVGTf</b>	Integration of Variable Generation Task Force (of NERC)
<b>JWD</b>	Japan Wind Development Co.
<b>MSB</b>	Market Strategy Board (of IEC)
<b>NDRC</b>	National Development and Reform Commission (of China)
<b>NEA</b>	National Energy Administration (of China)
<b>NERC</b>	North American Electric Reliability Corporation
<b>OECD</b>	Organisation for Economic Co-operation and Development
<b>ONS</b>	The Operator of the National Electricity System (of Brazil)
<b>NYISO</b>	New York Independent System Operator
<b>PES</b>	Power & Energy Society (of IEEE)
<b>PMA</b>	Power marketing administration
<b>REE</b>	Red Eléctrica de España
<b>RTO</b>	Regional transmission organization
<b>SAC</b>	Standardization Administration of China
<b>SGCC</b>	State Grid Corporation of China
<b>SMB</b>	Standardization Management Board (of IEC)
<b>TC</b>	Technical Committee (of IEC)
<b>TEPCO</b>	Tokyo Electric Power Company
<b>TSC</b>	TSO Security Cooperation
<b>TSO</b>	Transmission system operator
<b>UWIG</b>	Utility Wing Integration Group
<b>WAPA</b>	Western Area Power Administration (of US)
<b>WECC</b>	Western Electricity Coordinating Council



# SECTION 1

## **Introduction**

This report discusses the challenges of synthesizing the development and operation of RE and EES resources with the planning and operation of the rest of the power grid, including existing generation resources, customer requirements and the transmission system itself. The generation of electricity from RE sources includes technologies such as hydropower, wind power, solar power, tidal and wave power, geothermal power, and power from renewable biomass. Wind and solar power are the focus of this report, for two reasons. First, they are among the renewable generation types – wind, solar, and wave – that are subject to natural variability in their energy sources. This variability creates distinct challenges for integration into the larger power system, namely nondispatchability. Secondly, wind and solar are relatively mature for use in large capacities and in wide areas, and so have a significant impact on the power grid that is likely to increase over time.

Integration of RE is a poly-nodal problem involving multiple decision-makers at a variety of spatial and temporal scales and widely varying degrees of coordination. These decision-makers include operators of RE and energy storage resources, grid operators, energy market operators and transmission planning bodies. As such, grid integration is not performed by any one entity in the power system, but instead involves the actions of a variety of entities, some highly coordinated and others discrete. The burgeoning development of smart grids adds still more tools, options and players to the mix. Many of these actors engage with various technology standards, practices, procedures and policies for the operation of individual generators, RE clusters, substations, and the broader electrical energy system.

This report, produced by the International Electrotechnical Commission (IEC) Market Strategy Board (MSB), is the third in a series of MSB White Papers which already includes:

- 1) Coping with the Energy Challenge (September 2010), hereafter referred to as the “MSB EEE Report”;
- 2) Electrical Energy Storage (December 2011), hereafter referred to as the “MSB EES Report”.

The report’s primary goal is to provide a comprehensive, global view on the state of the art and future directions for grid integration of large-capacity RE sources and the application of large-capacity energy storage for that purpose. It is directed towards the IEC’s partners worldwide, as well as to its own Standardization Management Board (SMB) and Conformity Assessment Board (CAB), such that they may act to support grid integration efforts around the world and provide guidance to the electric utility industry and policy-makers.

The report is divided into seven sections: (1) Introduction; (2) RE generation: the present, the future and the integration challenges; (3) Present: state of the art in integrating large-capacity RE; (4) Future: technical solutions for integrating more large-capacity RE; (5) Application of large-capacity EES to support RE integration; (6) Standards for large-capacity RE integration; and (7) Conclusions and recommendations. Sections 1 and 2 provide background information about the report, the state of RE generation, and the challenges of integrating RE sources into the grid. Section 3



describes the key practices and technologies presently involved in grid integration of large-capacity RE. Section 4, the heart of the report, explores the future technology and practice needs of the grid as RE penetration increases. Section 5 discusses the role of energy storage as a supportive technology for grid integration of RE, and maps its supportive roles onto the general needs identified in Section 4. Section 6 connects the information from the previous

five sections with relevant IEC standards activities, and identifies future standards needs. Section 7 provides a strategic overview and recommendations to the relevant policy-makers, regulators, power utilities, industry and research communities, as well as the IEC's own committees.



# SECTION 2

**RE generation:  
the present, the future and  
the integration challenges**

## 2.1 Drivers of RE development

RE is a growing component of electricity grids around the world due to its contributions to (1) energy system decarbonization, (2) long-term energy security, and (3) expansion of energy access to new energy consumers in the developing world. As stated in the MSB EEE Report:

*In short: the challenge is ensuring energy availability and preserving the environment. The key elements are the following:*

- 1) *Stabilizing climate impact from fossil fuel use*
  - 2) *Meeting the energy demand of a growing population*
  - 3) *Bringing electricity to the 1.6 B people without access*
  - 4) *Ensuring stable and secure energy access for all nations*
  - 5) *Transporting electricity long distances from where it is generated to where it is used.*
- [msb10]

RE is implicated in all of these elements, and is critical to transforming energy grids to meet the environmental, economic and social challenges of the future. Globally, RE's share of electricity generation will increase substantially over the next two decades and beyond. Indeed, this is already occurring: governmental action at the international, national and subnational levels has created a wide variety of laws and policies to promote RE development. These include:

- carbon taxes: taxation of greenhouse gas emissions, so as to internalize the climate-disruption costs of fossil-fuel use;
- cap-and-trade systems: provision of tradable annual emissions allowances to greenhouse gas emitters coupled with reduction in the quantities of allowances issued each year;

- RE goals: mandates requiring load-serving entities to source a specified proportion of energy sold from renewable sources;
- feed-in tariffs (FiTs): guaranteed wholesale prices for RE coupled with a requirement that load-serving entities take renewable power whenever it is available;
- tax credits: credits against taxable income for generation or installation of RE;
- the development of smart grids: advances in the architecture, functionality and regulation of electricity grids so as to enable higher penetrations of RE; and
- removal of long-standing fossil fuel subsidies.

We will discuss the major public policy drivers behind RE development in turn.

### 2.1.1 Decarbonization

The need to address global climate change, a worldwide environmental phenomenon that will affect everyone on the planet, is the most public driving force for RE deployment. The Intergovernmental Panel on Climate Change (IPCC), the world's leading authority on climate change science, states in its Synthesis Report to the Fourth Assessment Report that "warming of the climate system is unequivocal, as is now evident from observations of increases in global average air and ocean temperatures, widespread melting of snow and ice and rising global average sea level", and that "most of the global average warming over the past 50 years is very likely due to anthropogenic greenhouse gas (GHG) increases and it is likely that there is a discernible human-induced warming averaged over each continent (except Antarctica)."

The MSB EEE Report notes that CO<sub>2</sub> emissions related to energy use account for 70% of total GHG emissions, and that emissions related to electricity generation approach half of that [msb10]. Consequently, governments have enacted policies to curb GHG emissions from the power sector. Because electricity generated from RE produces no GHG emissions, increasing penetrations of RE onto the electrical grid contribute to a *decarbonization* of the electricity system: a reduction in GHGs emitted per unit of energy produced. Energy system decarbonization in turn slows the increase in concentrations of GHGs in the atmosphere and thereby mitigates the resultant radiative forcing of the climate system.

In recent years, the ostensible progress of climate change policies has stalled at the international level, with a lack of hard commitments to emission reductions from some large emitters. Nevertheless, many countries have developed incremental policies to promote RE development in the absence of full international agreement. For example, nearly 30 states in the USA have enacted their own RE goals in the absence of federal action; Germany has long used aggressive feed-in tariff requirements that oblige power companies to purchase renewably-generated energy at fixed rates; and China has set a capacity goal of 150 GW-180 GW of wind power and 20 GW of solar photovoltaic (PV) power for 2020. These goals and policies will result in significant growth in RE that will affect the operation of the power grid.

### 2.1.2 Energy security

Driven by the wind, the sun and the waves, RE has no fuel costs. This zero-fuel-cost aspect of RE manifests itself in two benefits. First,

average energy costs tend to decline over time for renewable generation, as variable costs are limited to operations and maintenance and do not include fuel. Secondly, RE assets are insulated from fluctuations in fossil fuel prices, which are historically volatile and subject to geopolitical disruptions. Coal, gas and oil-fired generation costs, in contrast, increase when the cost of the relevant fuel increases. Figure 2-1 depicts the International Energy Agency's (IEA) projections<sup>1</sup> for the share of world electricity generation by fuel up to 2035, and shows a displacement of coal and oil-based generation's shares by wind, biomass and other renewables as governments continue to promote RE.

Because fossil fuel supplies are both unevenly distributed and ultimately exhaustible, many countries have identified a long-term energy-security proposition in gradually decreasing dependence on them in the production of electricity. In comparison to fossil resources, renewable resources are better distributed throughout the world and do not diminish as they are used. A country's investment in RE results in a zero-fuel-cost generation resource that is domestically located. Thus even countries with substantial fossil fuel resources, such as China, have set aggressive wind power targets. And despite a recent boom in natural gas production in the USA, states have made no indication of any intent to remove RE goals. RE can also prove useful for short-term energy security concerns. Many electric utilities have diversified their generation mixes with renewables so as to hedge against volatile fossil fuel prices on the oil, gas and coal markets.

---

<sup>1</sup> These projections come from IEA's New Policies Scenario, the centrepiece of IEA's analysis in its World Energy Outlook. The new policies scenario accounts for future policy developments that drive world energy sources toward greater sustainability.

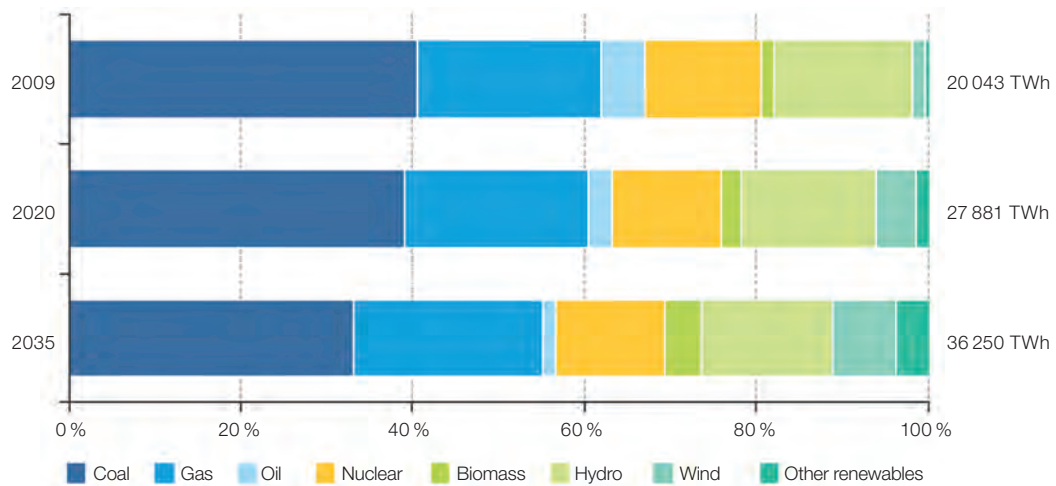

Figure 2-1 – Share of world electricity generation by fuel in IEA's New Policies Scenario  
[weo11]

### 2.1.3 Expanding energy access

Energy demand in developing countries is growing rapidly (see Figure 2-2). IEA's New Policies Scenario projects electricity demand in non-OECD countries to increase at a compound average annual growth rate (CAAGR) of 3.5% to 2035. Total non-OECD electricity demand nearly triples from 8 000 TWh in 2009 to almost 20 000 TWh by 2035 (see Figure 2-3). Asian electricity demand grows the most rapidly, with a 4.2% CAAGR in the same period. In addition to the needs outlined in the previous subsections for cleaner energy and more secure energy, the world simply needs *more* energy as more people in the developing world gain access to it.

As global energy demand increases, RE provides one means among many of adding energy assets to the system alongside growth of other resources. IEA's New Policies Scenario projects a near tripling of global use of RE, from 3 900 TWh in 2009 to 11 100 TWh in 2035, and growth in renewables accounts for nearly half of the total increase in generation by 2035. Indeed, under this scenario, a full third of global electricity generation will be supplied by RE (including hydroelectricity) by 2035. Figure 2-4 provides a breakdown of incremental renewables growth by technology. Note the large increase in wind power.



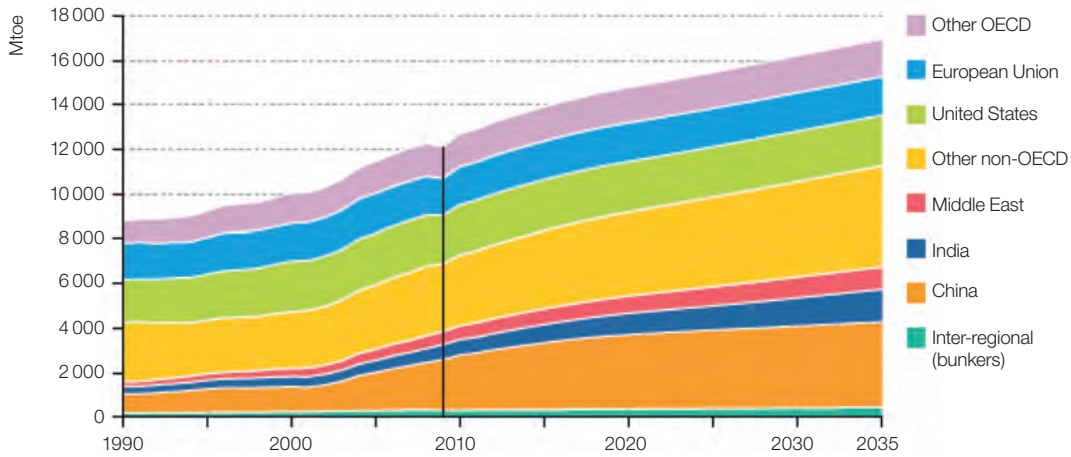

Figure 2-2 – World primary energy demand by region in IEA's New Policies Scenario  
[weo11]

			New Policies Scenario		Current Policies Scenario		450 Scenario	
	1990	2009	2035	2009-2035**	2035	2009-2035**	2035	2009-2035**
<b>OECD</b>	<b>6 593</b>	<b>9 193</b>	<b>12 005</b>	<b>1.0%</b>	<b>12 554</b>	<b>1.2%</b>	<b>11 343</b>	<b>0.8%</b>
Americas	3 255	4 477	5 940	1.1%	6 119	1.2%	5 612	0.9%
United States	2 713	3 725	4 787	1.0%	4 898	1.1%	4 505	0.7%
Europe	2 321	3 088	4 028	1.0%	4 244	1.2%	3 802	0.8%
Asia Oceania	1 017	1 628	2 037	0.9%	2 191	1.1%	1 930	0.7%
Japan	759	950	1 158	0.8%	1 225	1.0%	1 075	0.5%
<b>Non-OECD</b>	<b>3 492</b>	<b>8 024</b>	<b>19 717</b>	<b>3.5%</b>	<b>21 798</b>	<b>3.9%</b>	<b>16 978</b>	<b>2.9%</b>
E. Europe/ Eurasia	1 585	1 280	1 934	1.6%	2 238	2.2%	1 742	1.2%
Russia	909	791	1 198	1.6%	1 401	2.2%	1 057	1.1%
Asia	1 049	4 796	13 876	4.2%	15 334	4.6%	11 666	3.5%
China	559	3 263	9 070	4.0%	10 201	4.5%	7 447	3.2%
India	212	632	2 465	5.4%	2 590	5.6%	2 117	4.8%
Middle East	190	600	1 393	3.3%	1 525	3.7%	1 264	2.9%
Africa	263	532	1 084	2.8%	1 152	3.0%	1 000	2.5%
Latin America	404	816	1 430	2.2%	1 550	2.5%	1 306	1.8%
Brazil	211	408	750	2.4%	792	2.6%	675	2.0%
<b>World</b>	<b>10 084</b>	<b>17 217</b>	<b>31 722</b>	<b>2.4%</b>	<b>34 352</b>	<b>2.7%</b>	<b>28 321</b>	<b>1.9%</b>
European Union	2 227	2 793	3 530	0.9%	3 716	1.1%	3 351	0.7%

\*Electricity demand is calculated as the total gross electricity generated less own use in the production of electricity and transmission and distribution losses. \*\*Compound average annual growth rate.

Figure 2-3 – Electricity demand by region in IEA's WEO 2011 Scenario (TWh)  
[weo11]

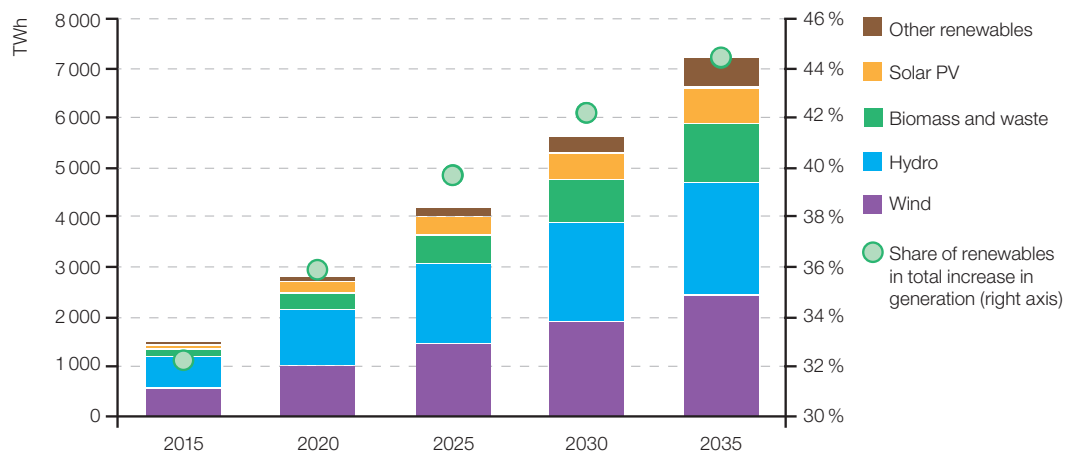

Figure 2-4 – Incremental global renewables-based electricity generation relative to 2009 by technology in IEA's New Policies Scenario  
[weo11]

While a world where a majority of electricity generation is based on renewable sources is far beyond the horizon, it is clear that the confluence of government policy, utility planning and global demand growth has the potential to increase penetrations of RE substantially on electricity grids worldwide. This shift in generation portfolios will have profound effects on the operation of the grid, which will in turn affect the operation of RE resources themselves as well as the operation of other resources and equipment connected to the grid.

## 2.2 Present status of RE generation and future projections

At 3 902 TWh, RE accounted for 19.46% of the world's electricity generation in 2009. Hydroelectricity, by far the largest contributor among the renewables, accounted for over 83% of that share. Biomass, wind and solar PV combined accounted for only 15% of the global

RE contribution, or 2.9% of world electricity generation [weo11]. Thus, while RE as a whole comprises a substantial portion of global electricity generation, the proportion of RE that comes from variable sources such as wind and solar is still relatively limited. Consequently most power system operators to date have had relatively small amounts of variable generation to integrate. As we examine here, however, the situation may change materially by 2035.

The IEA projects that global electricity production from renewables (including hydroelectricity) will grow to 8 108 TWh by 2025, an over-100% increase from 2009. By 2035, that figure rises to 11 100 TWh, as illustrated in Figure 2-5. These estimates are based on IEA's New Policies Scenario, which takes into account recently announced commitments and plans, even if they are yet to be formally adopted and implemented [weo11]. The New Policies Scenario is the central scenario for IEA's World Energy Outlook 2011, and assumes a global CO<sub>2</sub> price of 30 USD to 45 USD per tonne.

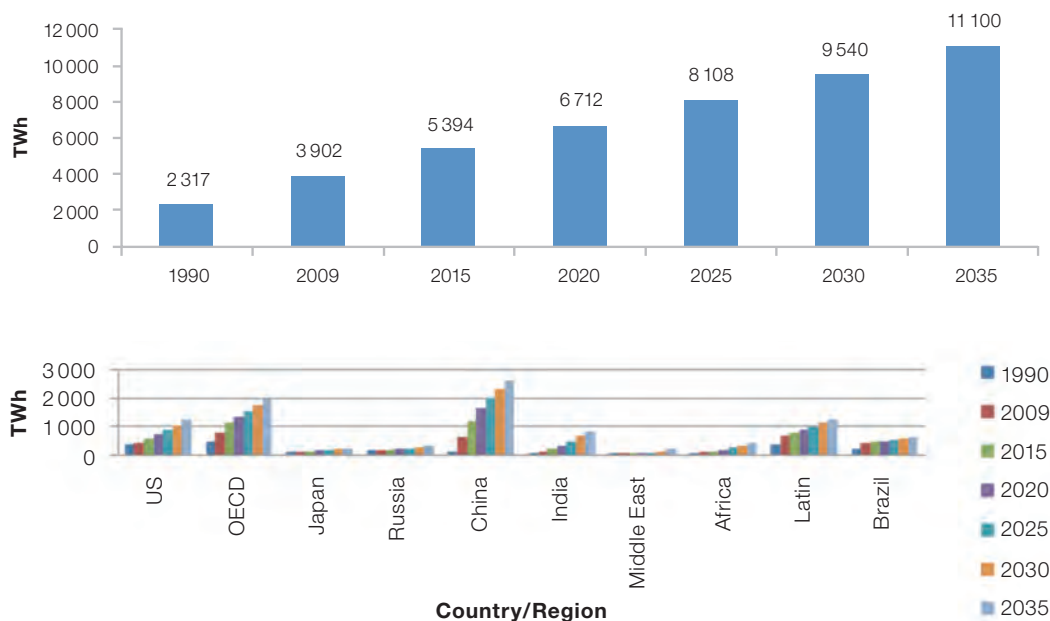

Figures 2-5 and 2-6 – RE generation globally and by country/region to 2035  
[weo11]

Figure 2-6 displays the projected growth of RE generation by region or country [weo11]. Notably, while the USA, OECD Europe, Latin America and China have relatively similar numbers in 2009, the growth rates are dramatically different. China's growth substantially outpaces OECD Europe's, and OECD Europe's growth substantially outpaces that of the USA and Latin America. Africa and the Middle East see relatively little growth in renewables. India exhibits an aggressive growth rate, but begins 2009 with smaller numbers than other regions, and so does not see the same degree of absolute growth as neighbouring China.

It is important to note that charts in this subsection referring to present RE capacities reflect the state of the market in 2009, which is the most recent year for which present data is available from the IEA. However, RE capacity has already expanded substantially since then,

with some notable developments in 2010. We discuss these developments in the text when relevant.

### 2.2.1 Wind energy

Wind energy plants around the world produced 273 TWh of electricity in 2009, from an estimated installed capacity of 159 GW. IEA's estimates of 2009 wind energy generation and capacity by region and country are provided in Figures 2-7 and 2-8 [weo11]. Wind power developments in 2010 have been substantial: China installed over 16 GW of new wind capacity in 2010, bringing its total to 42 GW. This exceeded the US 2010 total of 40 GW, and made China the world leader in wind capacity for the first time. Europe installed nearly 10 GW of wind in 2010, bringing its total capacity to 86 GW, over half of which is located in Germany and Spain [smp11].

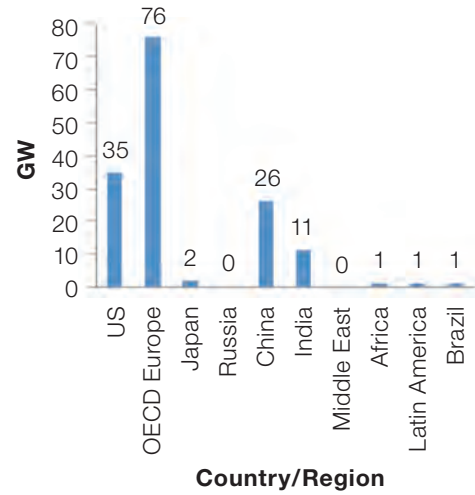
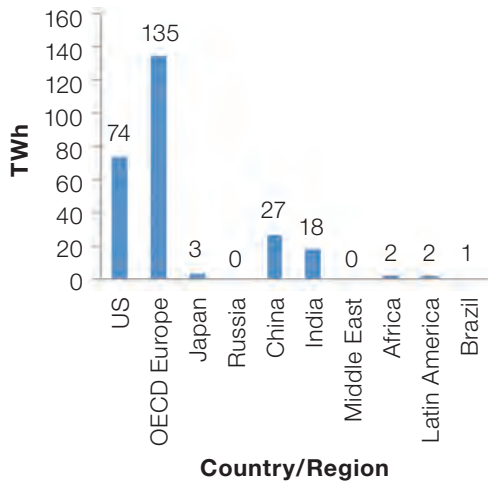

Figures 2-7 and 2-8 – Wind energy generation and capacity by country/region in 2009 [weo11]

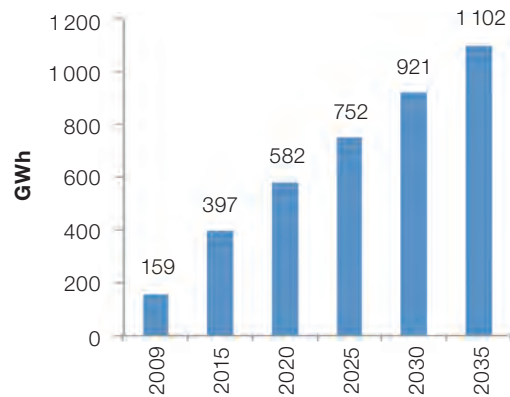
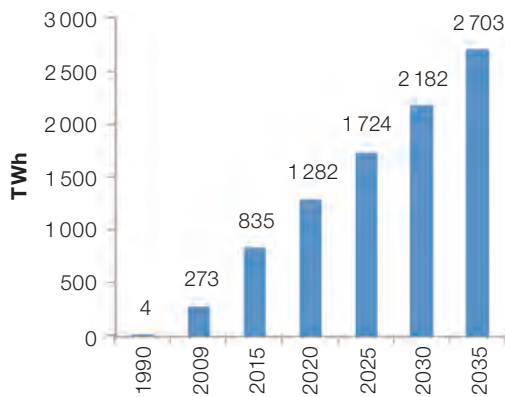

Figures 2-9 and 2-10 – Global wind energy generation and capacity projections to 2035 [weo11]

IEA's New Policies Scenario projects 1 282 TWh of annual wind-generated electricity globally by 2020 [weo11], a 369% increase from 2009. By 2030 that figure reaches 2 182 TWh, a near-doubling of the 2020 estimate over the course

of a decade, as shown in Figure 2-9 [weo11]. In terms of capacity, IEA projects growth from 159 GW in 2009 to 582 GW in 2020, reaching 1 102 GW by 2035, as shown in Figure 2-10 [weo11].

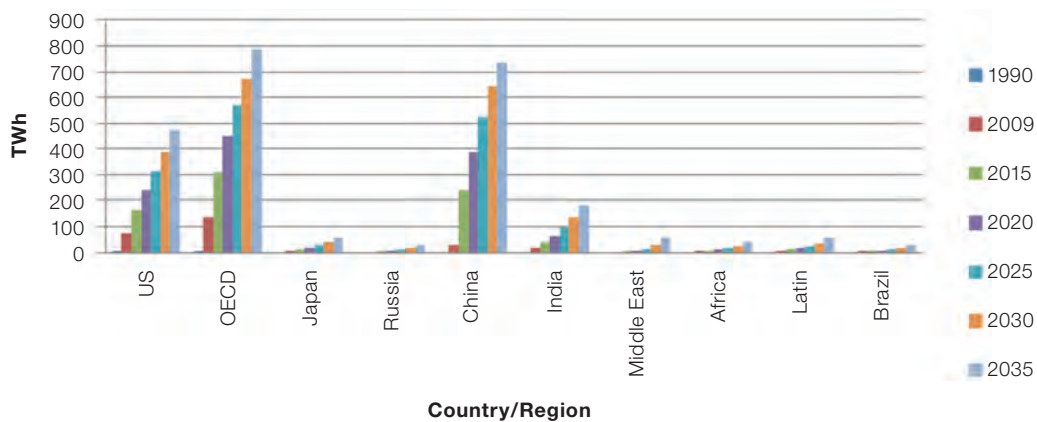

Figure 2-11 – Wind energy generation to 2035 by region/country  
[weo11]

Wind capacity growth over this period is dominated overwhelmingly by China, OECD Europe and the USA, as shown in Figure 2-11. Indeed, while the current disparity between these countries and the rest of the world in wind capacity is stark, it is dwarfed by future growth estimates, by which the leaders will outpace the others by orders of magnitude. OECD Europe and China maintain growth in lockstep through 2035, leaving the USA somewhat behind, though still a major player. It is also apparent that Latin America's growth in renewables overall does not translate to a significant growth in wind.

Regionally, the OECD European countries together show the strongest wind growth, slightly outpacing China. 76 GW of European wind power produced 135 TWh of electricity in 2009 [weo11]. Germany, Spain, Italy and France are the major contributors to wind energy capacity in this region [gwe10]. In Europe, the majority of wind farms developed during the past ten years have been onshore and small-capacity. With many wind-rich areas now thoroughly exploited, European wind developers are turning their attention to large-capacity offshore wind farms with centralized integration to the power grid.

By 2020, IEA projects wind capacity of 209 GW and 449 TWh of generation in Europe. By 2030, capacity reaches 289 GW and generation reaches 675 TWh [weo11]. Germany has set a target of 45.75 GW of wind capacity for 2020 [ger10], and Spain a target of 38 GW [esp10]. These plans contribute substantially to Europe's regional estimate, particularly in the next decade.

If we examine single countries rather than regions, China is the world's *tour de force* in wind power development. 26 GW of wind power supplied 27 TWh of electricity in China in 2009, ranking it third globally in wind capacity. A year later, China had jumped into first place with a total of 42 GW in 2010 [smp11] [weo11]. China is set to lead the world in wind generation and wind capacity by 2035. The IEA predicts China will produce 388 TWh of electricity from wind in 2020, and the National Energy Administration (NEA) of China has set a target of 150-180 GW of wind capacity by the same date [sgc12], which matches IEA's estimate of China's installed wind capacity of 180 GW. By 2030, IEA projects that China will reach 280 GW of wind capacity, just behind estimates for the combined European countries [weo11].

US wind capacity stood at 35 GW in 2009, generating 74 TWh of electricity [weo11]. Most of US wind capacity is concentrated in the states of Texas, Iowa, California, Michigan and Washington, and is onshore [wpa12]. As a result of declining energy demand, an economic recession and a precipitous drop in North American natural gas prices, the USA did not keep pace with Europe and China in 2010, installing only 5 GW to Europe's 10 GW and China's 16 GW. Still, the USA is expected to remain a significant player in wind. IEA projects that US wind generation will grow to 165 TWh by 2015, more than double its 2009 value. By 2030, the capacity grows to 388 TWh from 151 GW [weo11].

Japan's 2 GW of wind capacity produced 3 TWh of electricity in 2009 [weo11]. IEA estimates Japanese wind capacity to grow to 7 GW by 2020, producing 18 TWh of electricity, and to 15 GW by 2030, producing 41 TWh of electricity [weo11]. Though these numbers are dwarfed by those from geographically larger regions such as China, OECD Europe and the USA, it is worth noting that the expected rate of increase of wind generation and capacity on the Japanese grid is dramatic: generation is expected to grow by 650 % between 2009 and 2030 under the IEA's New Policies Scenario.

The figures above do not differentiate between onshore and offshore wind. However, the sorts of integration challenges presented may differ between onshore and offshore wind projects, specifically with regard to the need for special transmission technologies for offshore plants. We therefore briefly examine the offshore segment of the wind market, which at present exists almost entirely in Europe, with a few projects in China. Europe's offshore wind capacity stood

at 4 GW at the end of 2011, with an additional 6 GW under construction at the time and 17 GW consented to by EU member states [ewe11]. The majority of these projects are in the UK, Denmark and Germany, with some projects in Belgium, the Netherlands and Sweden. The European Wind Energy Association (EWEA), an industry association, projects that Europe will have 40 GW of offshore wind by 2020 producing 148 TWh of energy, and 150 GW producing 562 TWh by 2030. While industry estimates must be taken with the proverbial grain of salt, these numbers at least plausibly harmonize with IEA's OECD European wind (off- and onshore) projections of 209 GW by 2020 and 298 GW by 2030. EWEA itself identifies the availability of high voltage direct current transmission (HVDC) as a critical bottleneck for the development of offshore wind in Europe.

### 2.2.2 Solar energy

Grid-relevant solar energy technologies can be divided into two types: PV and concentrated solar power (CSP). PV generates electricity directly, converting sunlight to electricity through a semiconductor such as silicon. CSP technologies produce electricity by reflecting and concentrating sunlight onto a fluid, which then heats and boils water, the steam from which then drives a turbine that produces electricity. Presently, CSP has a lower contribution to RE production than solar PV. We will discuss each market in turn, beginning with the larger PV market.

Solar PV generated 20 TWh of electricity from 22 GW of global capacity in 2009 (see Figures 2-12 and 2-13) [weo11]. The OECD Europe region far surpassed all other regions in both capacity and generation, despite its relatively weak solar

resource. This apparent discrepancy is explained by highly favourable policy environments for solar PV in many European countries.

Though solar PV capacity is many times smaller than wind capacity at present, it is expected to grow at a faster pace than wind over the next

several decades. The IEA projects solar PV generation of 230 TWh from 184 GW of capacity in 2020, an over 1000 % generation increase from 2009. By 2030, those figures reach 551 TWh and 385 GW, more than double the 2020 estimates. Figures 2-14 and 2-15 display IEA's projections for solar PV energy production to 2035 [weo11].

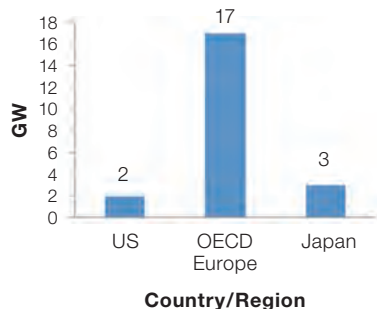
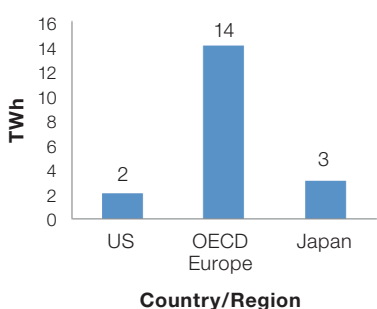

Figures 2-12 and 2-13 – Solar PV energy generation and capacity in 2009 by country/region [weo11]

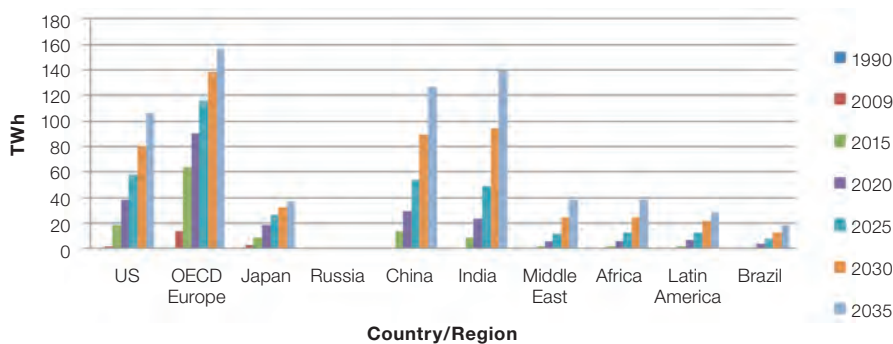
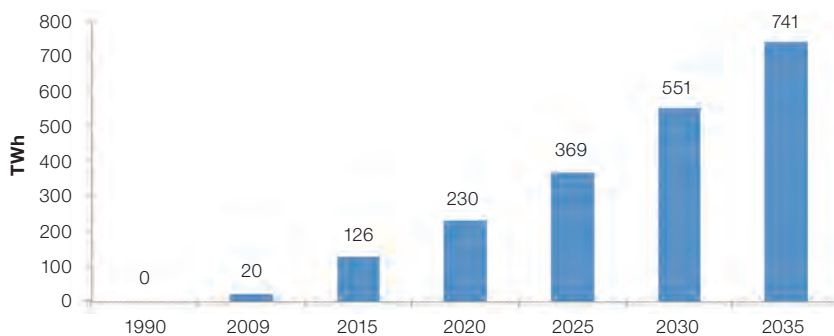

Figures 2-14 and 2-15 – Energy generation from solar PV globally and by country/region [weo11]



In the OECD Europe region, solar PV produced 14 TWh of electricity from 17 GW of solar PV capacity in 2009 [weo11]. Favourable government policies and pricing have led to higher penetrations, particularly in Spain, Italy and Germany. In Germany, the government has opted for a feed-in tariff, in which the utilities pay the owner of a solar PV system a set tariff for renewable power over a period of time [obo12]. Consequently, solar PV provided 3% of the total power in Germany in 2011 [eck11]. Germany led the world in PV capacity in 2009 with 9 785 MW. Spain's 2009 capacity figure, at 3 386 MW, was lower but still substantial in comparison to other countries [epa10]. Italy has ramped up solar PV capacity dramatically since then, reaching 12 750 MW and producing 10 TWh of energy in 2011 [gse12].

IEA projects 90 TWh from 84 GW of OECD European capacity by 2020 and 139 TWh from 115 GW by 2030 [weo11]. Germany expects its solar PV capacity to reach 52 GW by 2020 [ger10], and Spain estimates 8.4 GW by the same year [esp10]. It is worth noting that Europe's generation capacity factors (the ratio of energy generated from a given unit of power) for solar PV are lower than those for the USA. This disparity is explained by differences in the quality of the resource: the USA receives much more sunlight than Europe. Nevertheless, Europe's policy environment provides substantially more support to solar power, particularly in Germany and Spain, than does the US policy environment, explaining the capacity estimate differences as well as the ultimately higher generation estimates for Europe.

US solar PV generated 2 TWh of electricity from 2 GW of capacity in 2009 [weo11]. IEA estimates US solar PV generation at 38 TWh from 25 GW

of capacity in 2020 and 81 TWh from 50 GW of capacity in 2030. [weo11] Note that the 2030 estimate for US solar PV capacity is roughly a third of estimated US wind power capacity in the same year.

Japan generated 3 TWh of its electricity from solar PV sources in 2009 from 3 GW of capacity [weo11]. By 2010, Japan had increased its solar PV capacity to 3.6 GW. This increase is attributable to a subsidy programme for residential PV system installations and another programme to purchase surplus PV power from small systems at double the retail electricity price [yam11]. IEA projects 18 TWh of electricity from 17 GW of Japanese solar PV by 2020, and 32 TWh from 28 GW by 2030 [weo11].

China did not produce any significant amounts of electricity from solar PV in 2009, but that is changing rapidly, as it has become a manufacturing leader in the technology. IEA projects that China will produce 29 TWh from 20 GW of solar PV by 2020, and 89 TWh from 58 GW by 2030 [weo11]. This places China behind the USA in solar PV generation in 2020, but ahead of it by 2030 [weo11]. China's National Development and Reform Commission has set targets for China to achieve 10 GW of solar capacity in 2015, and 50 GW of solar capacity installed by 2020 [won11].

CSP's market is much smaller than wind power or solar PV, and it is less challenging to integrate into the power system due to its thermal aspects, which reduce variability in output. CSP produced 1 TWh of electricity in 2009 from a global capacity of 1 GW, located primarily in the USA, though Spain has since taken the lead [weo11].



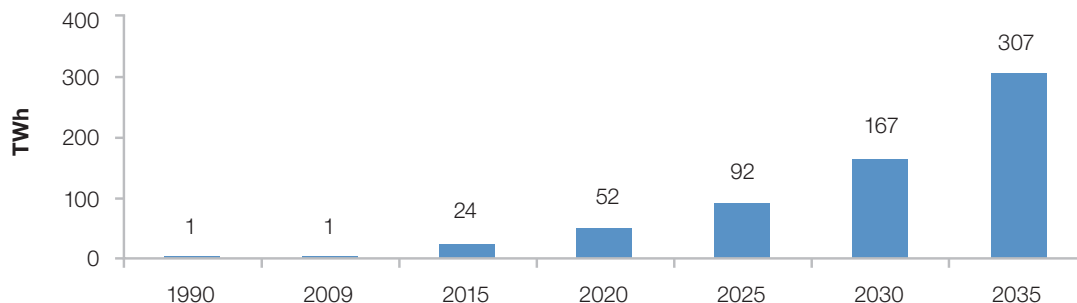

Figure 2-16 – Global CSP energy generation to 2035  
[weo11]

CSP generation estimates are lower than those for PV, but exhibit similar strength in growth rates. IEA projects 52 TWh of CSP-generated energy from 14 GW of capacity in 2020, and 167 TWh from 45 GW in 2030. Figure 2-16 displays IEA's projections for global CSP generation to 2035 [weo11].

Spain led the world in 2010 in CSP capacity at over 632 MW. Spanish CSP capacity grew by 400 MW in 2010 due to a Royal Decree from the Spanish government that provided incentives for solar energy. In 2011, it began construction on nearly 1 GW of additional CSP capacity [rep11]. IEA projects 14 TWh of electricity from 4 GW of CSP sources in OECD Europe by 2020. In 2030, that rises to 36 TWh from 10 GW. The Spanish government, however, estimates that Spain alone will install 5 GW of CSP to produce 15.35 TWh by 2020, more than IEA's projection for all of Europe [esp10].

IEA projections for US CSP closely track those for OECD Europe, with 14 TWh from 4 GW in 2020, and 30 TWh from 8 GW in 2030.

### 2.3 RE grid integration challenges

Wind and solar generation both experience intermittency, a combination of *non-controllable variability* and *partial unpredictability*, and depend on resources that are *location-dependent* [per11]. These three distinct aspects, explained below, each create distinct challenges for generation owners and grid operators in integrating wind and solar generation.

- **Non-controllable variability:** Wind and solar output varies in a way that generation operators cannot control, because wind speeds and available sunlight may vary from moment to moment, affecting moment-to-moment power output. This fluctuation in power output results in the need for additional energy to balance supply and demand on the grid on an instantaneous basis, as well as ancillary services such as frequency regulation and voltage support. Figure 2-17 provides a graphical example of hourly wind power variability.

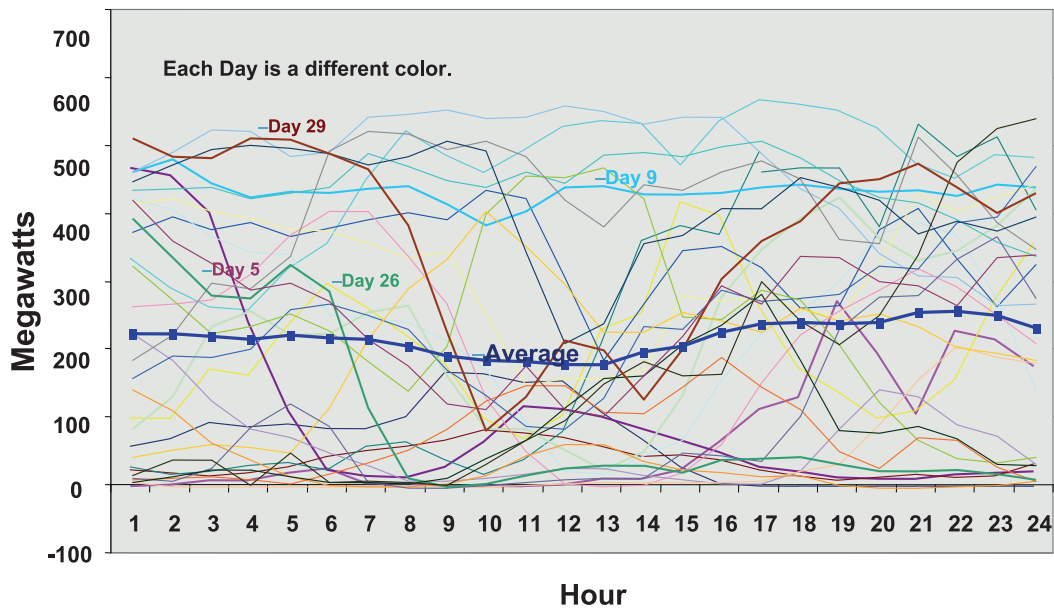

Figure 2-17 – Hourly wind power output on 29 different days in April 2005 at the Tehachapi wind plant in California

[haw06]

- Partial unpredictability:** The availability of wind and sunlight is partially unpredictable. A wind turbine may only produce electricity when the wind is blowing, and solar PV systems require the presence of sunlight in order to operate. Figure 2-18 shows how actual wind power can differ from forecasts, even when multiple forecast scenarios are considered. Unpredictability can be managed through improved weather and generation forecasting technologies, the maintenance of reserves that stand ready to provide additional power when RE generation produces less energy than predicted, and the availability of dispatchable load to “soak up” excess power when RE generation produces more energy than predicted.
- Location dependence:** The best wind and solar resources are based in specific locations and, unlike coal, gas, oil or uranium, cannot be transported to a generation site that is grid-optimal. Generation must be co-located with the resource itself, and often these locations are far from the places where the power will ultimately be used. New transmission capacity is often required to connect wind and solar resources to the rest of the grid. Transmission costs are especially important for offshore wind resources, and such lines often necessitate the use of special technologies not found in land-based transmission lines. The global map in Figure 2-19 displays the latest data on mean land-based wind speeds around the world.

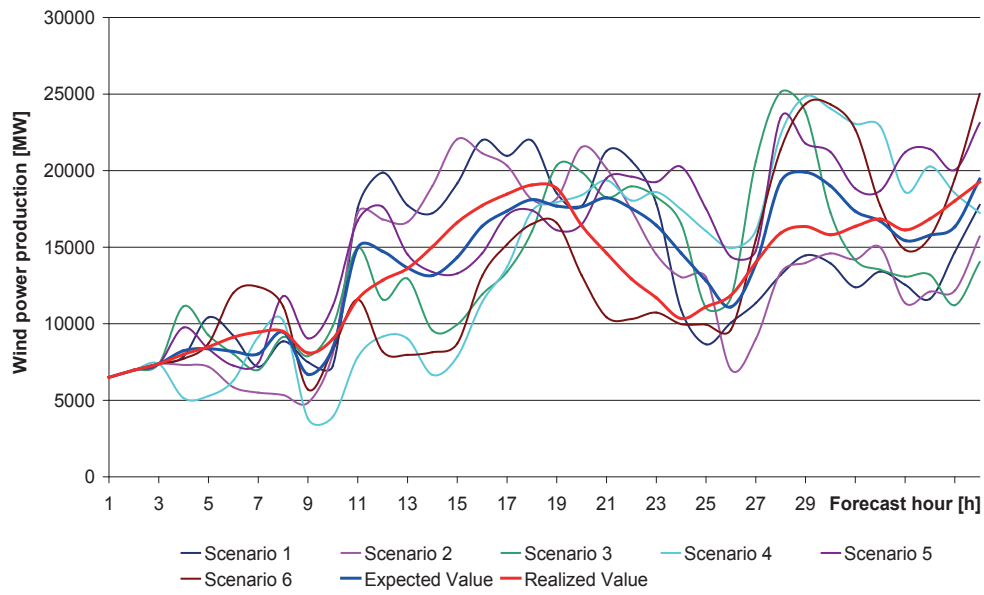

Figure 2-18 – Example of a day-ahead forecast scenario tree for the wind power forecast for the PJM region of the United States  
[mei10]

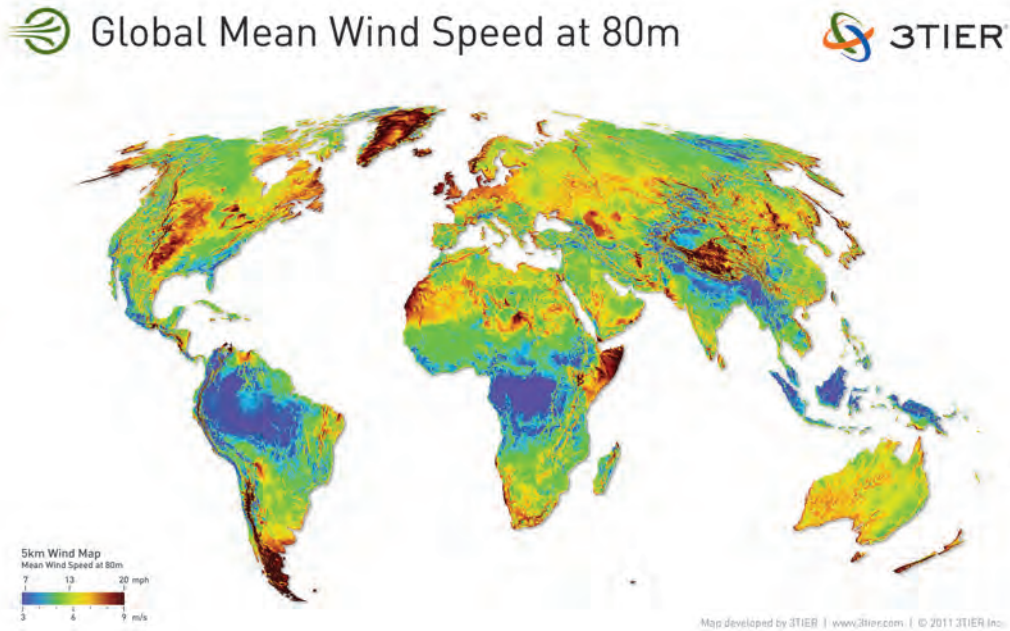

Figure 2-19 – Global mean wind speed at 80 m altitude  
[tie12]

Because the presence of wind and sunlight are both temporally and spatially outside human control, integrating wind and solar generation resources into the electricity grid involves managing other controllable operations that may affect many other parts of the grid, including conventional generation. These operations and activities occur along a multitude of time scales, from seconds to years, and include new dispatch strategies for rampable generation resources, load management, provision of ancillary services for frequency and voltage control, expansion of transmission capacity, utilization of energy storage technologies, and linking of grid operator dispatch planning with weather and resource forecasting [per11].

The essential insight to integration of variable RE is that its variability imposes the need for greater flexibility on the rest of the grid, from other (controllable) generators to transmission capacity to loads. Discussion of variable generation operation alone is insufficient to describe the full impact of high penetrations of RE on power system operation. Thus this report explores RE integration from both a plant operator and a system operator perspective, so as to identify the full range of operations involved.

### 2.3.1 Non-controllable variability

*Variability* in the context of wind and solar resources refers to the fact that their output is not constant. It is distinct from *unpredictability*, which we discuss in the following section. Even if operators could predict the output of wind and solar plants perfectly, that output would still be variable, and pose specific challenges to the grid operator, which we introduce here [per11].

On the seconds to minutes time scale, grid operators must deal with fluctuations in frequency and voltage on the transmission system that, if left unchecked, would damage the system as well as equipment on it. To do so, operators may order generators to inject power (active or reactive) into the grid not for sale to consumers, but in order to balance the actual and forecasted generation of power, which is necessary to maintain frequency and voltage on the grid. These *ancillary services* go by a plethora of names and specific descriptions. Typical services for an impressionistic overview include:

- frequency regulation: occurs on a seconds-to-minutes basis, and is done through automatic generation control (AGC) signals to generators;
- spinning reserves: generators available to provide power typically within 10 minutes. These reserves are used when another generator on the system goes down or deactivates unexpectedly;
- non-spinning reserves: these generators serve the same function as spinning reserves, but have a slower response time;
- voltage support: generators used for reactive power to raise voltage when necessary;
- black-start capacity: generators available to re-start the power system in case of a cascading black-out.

Additionally, grid operators must track *loads* – demand for electricity on the consumption side of the grid – and ensure that generation matches load at all times. This *load following* function becomes particularly important at times of day when demand for electricity increases substantially, such as morning, a hot afternoon, or evening. Load following may be provided through a class of ancillary service or

through a “fast energy market”, depending on the system operator.

These functions are not new. Grid operators have been regulating frequency and voltage, maintaining reserves and following shifts in load since the development of the electricity grid. This is because loads themselves are variable, and even conventional, controllable generation experiences problems and cannot perform as scheduled all of the time. Consumers demand electricity in ways that, while predictable, are not controllable and have some degree of variability. Thus wind and solar generation does not introduce entirely novel problems with which operators have never grappled. Indeed, at low penetrations, the integration challenges are primarily device and local-grid specific, such as subsynchronous resonance and harmonics, which the turbine itself may cause. These issues are explained in greater detail in section 3, and their solutions tend to be device-specific rather than grid-level.

However, high penetrations of wind and solar generation will add *more* variability to the energy system than grid operators have traditionally managed in the past, and thus increase demand for ancillary services and balancing energy overall. It is more difficult, and sometimes impossible, to manage such challenges at the device level, and so grid-level actions, technologies and strategies are often needed. Wind and solar resources in sufficient amounts may also complicate load following functions when large demand shifts coincide with weather events that alter power output from wind or solar resources. Grid operators located in more remote regions and serving smaller loads may have less flexibility to provide ancillary services and load following than their larger counterparts. Compounding matters, plentiful RE resources are often located

in these remote locations. The IEA and other bodies have recommended consolidation of grid operators, in order to integrate RE sources over larger areas and so reduce the variance of the power produced, as well as easing of market restrictions on sales of ancillary services as a solution to this problem [iea09].

### 2.3.2 Partial unpredictability

Partial unpredictability, also called *uncertainty*, is distinct from variability. The variability of wind and solar generation is ever-present, a result of reliance on the ever-changing wind and sun, and affects the system at the moment-to-moment time scale as a cloud passes over a PV plant or the wind drops. Partial unpredictability, on the other hand, refers to our inability to predict with exactness whether the wind and sun will be generally available for energy production an hour or a day from now. This hour-to-day uncertainty is significant because grid operators manage the great majority of energy on the grid through “unit commitment”, the process of scheduling generation in advance, generally hours to a full day ahead of time, in order to meet the expected load. When actual production does not match the forecast, the grid operator must balance the difference. RE generation increases the cost of this function by increasing the spread between predicted and supplied energy, a cost that is ultimately borne by consumers.

Unit commitment at present is largely *deterministic*, meaning that once a generator is scheduled to run, its full capacity is expected to be available for use. This practice reflects the relative predictability and controllability of traditional coal, gas and hydropower generation resources. Operators ensure the availability of

reserves – generators that withhold the supply of energy and so stand ready to balance the system in an emergency – so as to protect against a potential transmission line or generator outage.

But the process of unit commitment and the calculation of reserves needed to ensure reliability becomes more complex when dealing with *stochastic* (uncertain) generation, whose output at the committed time carries some degree of uncertainty. *Forecasting* technologies aim to predict weather and thus generation output from wind and solar resources at various time-scales more accurately, and communicate those predictions to grid operators in a manner that allows the operator to more effectively schedule and dispatch resources. Properly anticipating wind and solar output levels allows the operator to modify the scheduling of other generators so as to more optimally utilize all assets under the grid operator's purview. The operator must, for example, ensure that reserves are available not only to cover transmission line or generator outages, but also to respond to still unanticipated changes in wind and solar output. Assisting the operator in this process are *advanced unit commitment methods*, which aim to prepare the system for multiple potential and uncertain outcomes that cannot be predicted by the forecasting technologies. Unlike deterministic unit commitment processes, advanced unit commitment methods must take into account the stochastic nature of wind and solar generation and their relative concentration on the system in recommending the scheduling of other resources. Ultimately, the goal of advanced unit commitment is to cost-effectively maintain sufficient flexibility on the system, such that the integration of RE resources neither exposes the system to unacceptable reliability risks nor over-schedules reserves in a way that unnecessarily burns fuel and emits pollution.

### 2.3.3 Locational dependency

Far removed from the day-to-day management of the grid is its long-term planning – specifically the siting and utilization of new transmission lines. Here RE generation plays a significant role and introduces new challenges. Because wind and solar resources are often located in remote locations, far from load centres, developing sufficient transmission to move RE to markets is critical to their integration.

Transmission planning processes are highly varied, and tend to be influenced by regional politics. For example, a transmission line may provide capacity for energy produced in one country or state, passed through another, and consumed in yet another. These disparities in generation capacity, transmission location and load size between locations can make the development of transmission for RE contentious and complex, particularly with respect to cost allocation.

Because new transmission lines built out to RE generation resources will carry primarily renewably generated, variable and partially unpredictable electricity, technical needs arise regarding the transmission technology to be used.

On the other hand, distributed energy resources provide for an alternative vision of the future grid, where energy is generated and used locally on a *micro-grid*, avoiding the cost of line losses and the high capital cost of transmission lines. In such a schema, the electricity grid could be conceptualized as a collection of independent micro-grids with vastly reduced long-distance energy transmission needs.

# SECTION 3

**Present: state of the art in  
integrating large-capacity RE**



### 3.1 General

Although on a system-wide level RE power plants generate electricity just like any other power plants, RE power has quite distinctive characteristics in generation, transmission and operation technology when compared to conventional generation. Understanding these distinctive characteristics and their interaction with the other parts of the power system is the basis for the integration of large-capacity RE power in the grid.

In this chapter, the state of the art of the technologies and practices related to large-capacity RE integration is described to facilitate the understanding of their interaction with the power grid. This discussion is further divided into the RE generation technology itself, the

transmission technology and the operational technology and practices.

### 3.2 RE generation technology

#### 3.2.1 Wind power generation

##### 1) Basics of wind power generation

Wind turbine generators (WTGs) extract energy from wind and convert it into electricity via an aerodynamic rotor, which is connected by a transmission system to an electric generator [iea11]. Today's mainstream WTGs have three blades rotating on a horizontal axis, upwind of the tower (see Figures 3-1 and 3-2). Two-blade WTGs (see Figure 3-3) and vertical-axis WTGs (see Figure 3-4) are also available.



Figure 3-1 – A standard WTG with three blades and horizontal axis  
(SGCC)



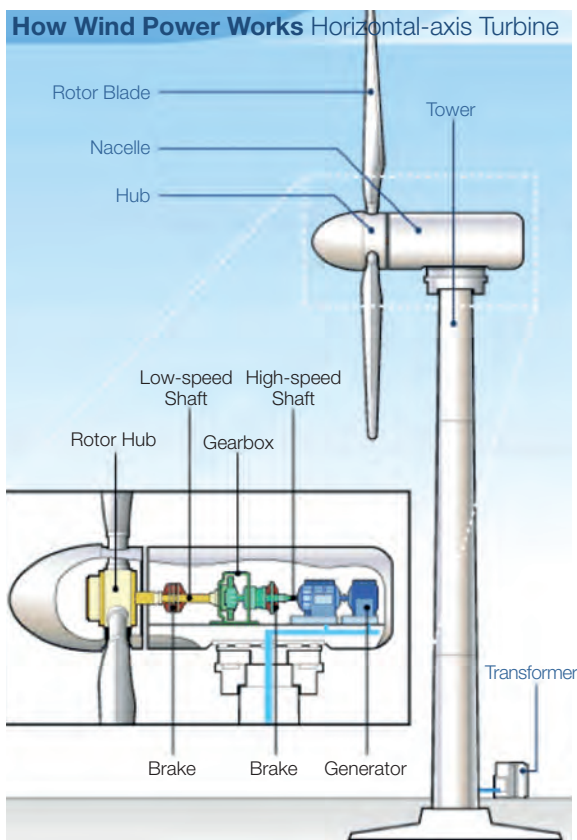

Figure 3-2 – Structure diagram of a WTG  
(HowStuffworks)



Figure 3-4 – Vertical-axis turbine  
(Xu Ji)

In general, a WTG can begin to produce power in winds of about 3 m/s and reach its maximum output around 10 m/s to 13 m/s. Power output from a WTG increases by the third power of wind speed, i.e. a 10% increase in wind speed increases available energy by 33%, and is directly proportional to the rotor-swept area (the area swept by the rotating blades). Power output can be controlled both by rotating the nacelle horizontally (yawing) to adapt to changes in wind direction, and rotating the blades around their long axes (pitching) to adapt to changes in wind strength.



Figure 3-3 – Two-blade WTG  
(Ming Yang)

The capacity of WTGs has doubled approximately every five years, but a slowdown in this rate is likely for onshore applications due to transport, weight and installation constraints. Typical commercial WTGs at present have a capacity of 1.5 MW-3 MW; larger ones can reach 5 MW-6 MW, with a rotor diameter of up to 126 metres [iea11].

Since a single WTG has limited capacity, much less than a conventional power generator, a wind power plant (WPP, usually called “wind farm”)

normally consists of many WTGs connected together by overhead lines or cables. Their power output is collected and transmitted to the grid through an alternating current (AC) or

direct current (DC) line, after voltage step-up at the substation in the WPP (see Figure 3-5). Some WPPs now have a capacity comparable to that of conventional power generators.

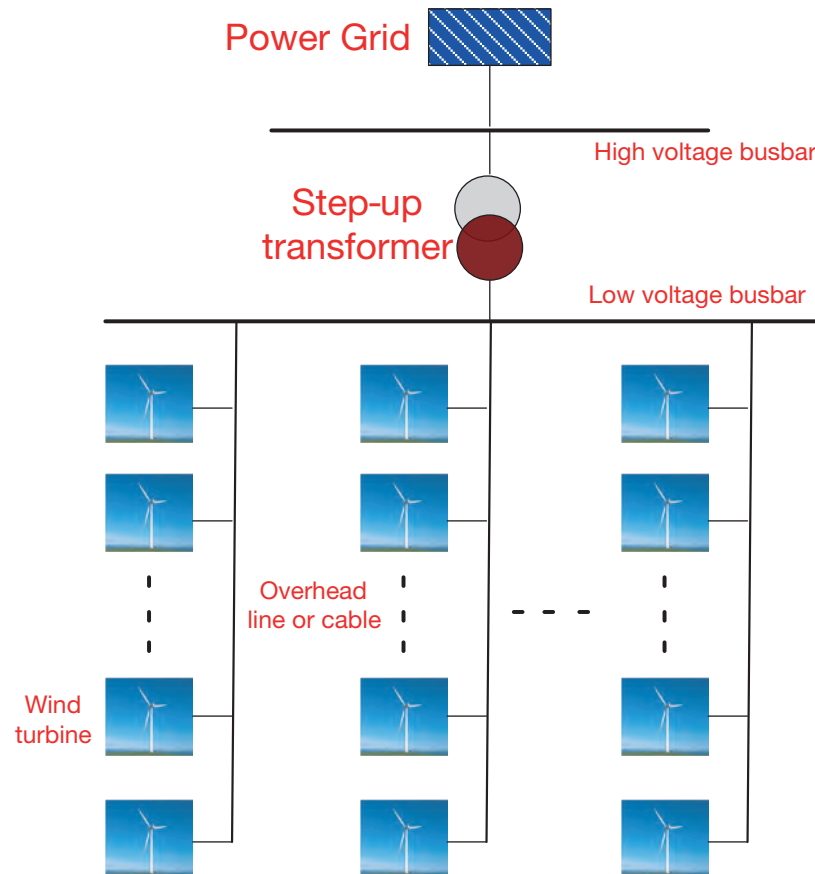

Figure 3-5 – Structure diagram of a wind farm (SGCC)

## 2) Types and characteristics of major WTGs

WTGs currently in operation mainly include the following four types. Each type has some unique characteristics due to its features in topology [ewe05] [ner09] [sge11].

**Type 1 – Fixed speed induction generator:** Introduced and widely used in the 1980s, type 1

WTGs (see Figure 3-6) are based on a squirrel cage induction generator (SCIG). They can only slightly vary their rotation speed (1%-2%), i.e. they are almost “fixed speed”, thus their output fluctuates as wind speed varies. To alleviate this problem, a double-speed version of the type 1 WTG was developed. Original type 1 WTGs have few control options but passive stall. Active stall designs can be adopted in improved type 1

WTGs, where the blades can pitch towards stall by a control system. Because induction generators absorb a lot of reactive power when generating

active power, type 1 WTGs are generally equipped with reactive power compensators.

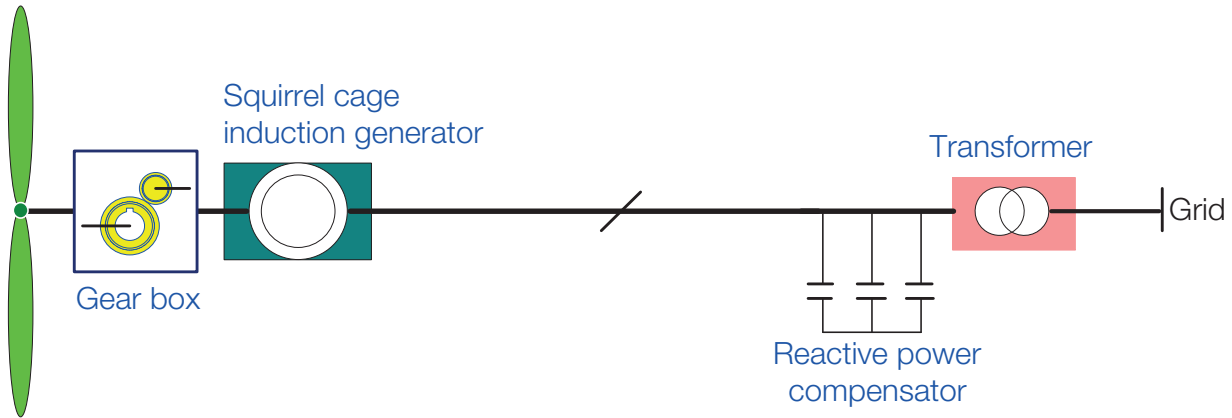

Figure 3-6 – Topology of a fixed speed induction generator (SGCC)

**Type 2 – Variable-slip induction generator:**

Introduced in the 1980s and 1990s, type 2 WTGs (see Figure 3-7) are equipped with a wound rotor induction generator (WRIG). Power electronics are applied to control the magnitude of the WRIG's rotor current, which allows a speed variation of

10% up and down, improving power quality and reducing the mechanical loading of the turbine components. Type 2 WTGs are equipped with an active pitch control system. Like type 1 WTGs, type 2 WTGs are also generally equipped with reactive power compensators.

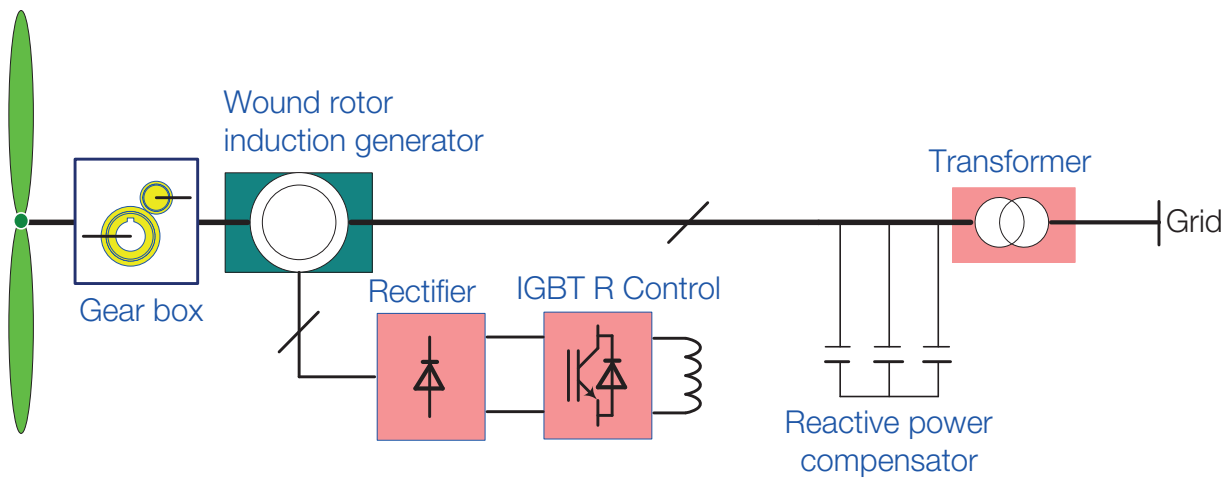

Figure 3-7 – Topology of a variable-slip induction generator (SGCC)

**Type 3 – Doubly fed induction generator (DFIG):** As the most popular WTGs at present, type 3 WTGs (see Figure 3-8) combine the advantages of previous WTG designs with advances in power electronics. The WRIG's rotor is connected to the grid through a back-to-back insulated gate bipolar transistor (IGBT) power converter that controls both the magnitude and frequency of the rotor current. Up to about 40 % of the power output goes through the converter

to the grid, the rest directly to the grid. This design can provide approximately 40 % up and down speed variation, maximizing wind energy capture. The converter provides decoupled control of active and reactive power, enabling flexible voltage control without additional reactive power compensation, as well as fast voltage recovery and voltage ride-through. Pitch control is also incorporated.

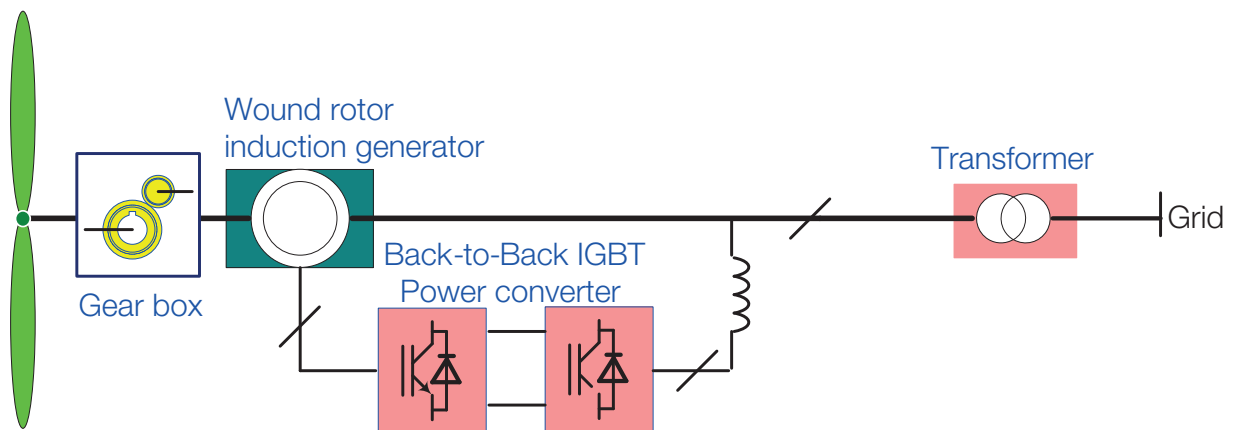

Figure 3-8 – Topology of a doubly fed induction generator (SGCC)

**Type 4 – Full-power conversion WTG:** In a type 4 WTG (see Figure 3-9), the stator of the generator is connected to the grid via a full-power back-to-back IGBT power converter, which means all the power output goes to the grid through the converter. The generator may be a synchronous generator with wound rotors, a permanent magnet generator or a SCIG. The gear box may be classical (drive-train), a low

speed step-up one (half direct-drive), or there may even be no gear box (direct drive). A type 4 WTG has similar characteristics to type 3 and, since it is completely decoupled from the grid, it can provide an even wider range of speed variation as well as reactive power and voltage control capability. In addition, its output current can be modulated to zero, thereby limiting the short-circuit current contribution to the grid.

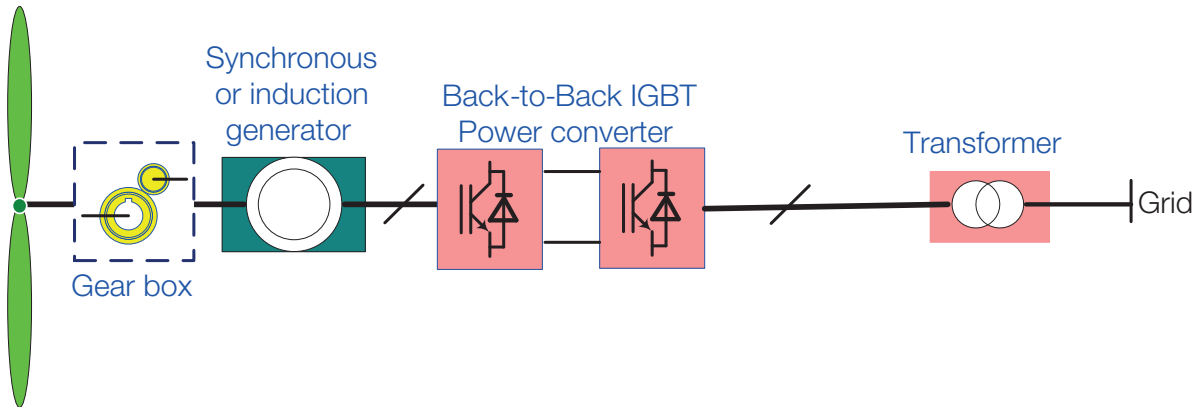

Figure 3-9 – Topology of a full-power conversion WTG (SGCC)

### 3) Offshore wind power generation

Offshore sites generally have better wind resources than onshore sites, so WTGs installed in offshore sites can achieve significantly more full-load hours. Offshore wind farm development can also relax many constraints faced by onshore wind farms, such as transport and land occupation. Today’s offshore WTGs are essentially large onshore ones with, for example, enhanced corrosion protection. A specific offshore wind power industry is developing and a specific offshore supply chain is emerging [iea11]. A number of WTG manufacturers have now developed large WTGs with a capacity of more than 3 MW for the offshore wind power market, and some have been installed for trials. Future WTGs will be even larger and specially tailored for offshore applications. Offshore wind farms will also be large in scale compared to onshore wind farms. For instance, several planned projects in the North Sea and the East China Sea have capacities of well over 1 000 MW.

However, a number of issues make the construction of offshore wind farms more

challenging and costly than onshore wind farms, such as support structures for the large turbines, difficult weather conditions, lengthy and costly transmission cables and extended transmission systems, high wind speed and deep water, environmental issues and the impact on other marine stakeholders [iea11]. In spite of this, offshore wind power is growing and will grow more rapidly in the future with improvements in the technology.



Figure 3-10 – The Shanghai Donghaidaqiao offshore wind farm (SGCC)

### 3.2.2 PV power generation

#### 1) Basics of PV power generation

Made of semiconductor materials, a photovoltaic (PV) cell directly converts solar energy into direct-current electricity. When sunlight shines on an individual PV cell, the energy that the cell absorbs from the sunlight is transferred to electrons in the atoms of the semiconductor material. These energized electrons then become a part of the electrical current in the circuit, generating electricity.

PV cells are connected in series and in parallel to one another to form PV modules with capacities of typically 50 W-200 W. PV modules, combined with a set of additional application-dependent system components (e.g. inverters, sun trackers, batteries, electrical components and mounting systems), form a PV system, which is highly modular, with capacities ranging from a few watts to tens of megawatts [iea11]. Large utility-scale PV systems are usually called PV power stations. The structure diagram of a PV power station is given in Figure 3-11.

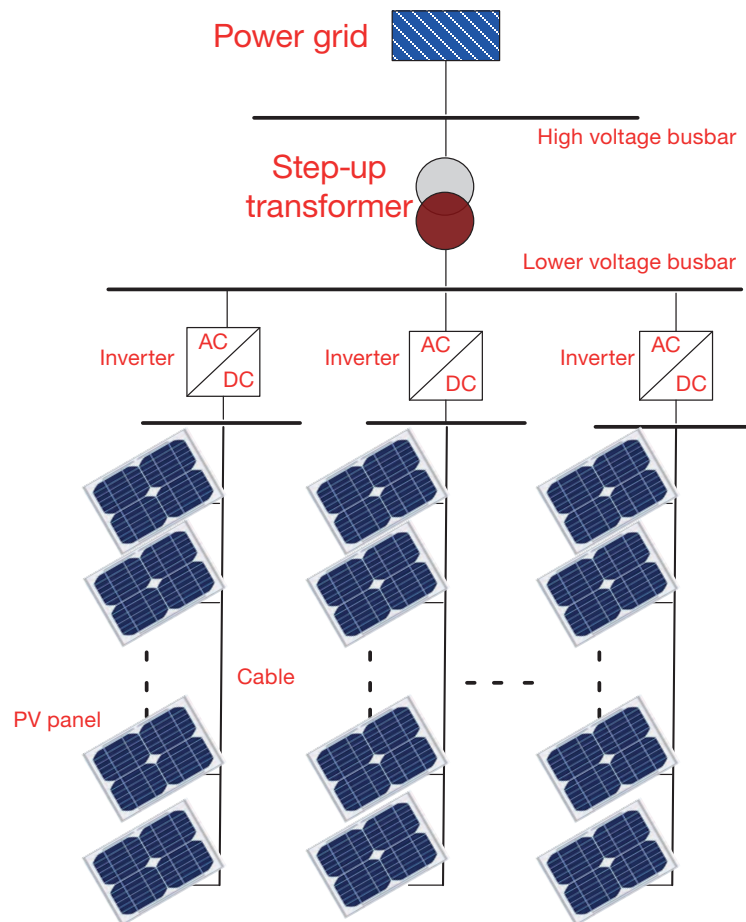

Figure 3-11 – Structure diagram of a PV power station



## 2) Types of PV power generation technologies

According to the materials and design, current PV power generation technologies can be classified into crystalline silicon, thin-film and concentrating PV (see Figures 3-12 and 3-13). Crystalline silicon PV is currently the best-established PV technology, with an energy conversion efficiency of up to 20%. More recently, thin-film PV, which can also use non-silicon semiconductor materials, is gaining

attention. Although thin-film PV generally has a lower efficiency than silicon PV (around 11%), it is less expensive and less energy-intensive to manufacture and is also more flexible for versatile applications. Concentrating PV, in which sunlight is concentrated and strengthened by a lens before it reaches the PV cells, is on the edge of entering full market deployment. Concentrating PV can reach an efficiency of up to 40%. Other technologies, such as organic PV cells, are still in the research phase [hts09] [jea11].



(a) A-Si Thin-film PV

(b) Polycrystalline silicon PV

Figure 3-12 – Thin-film and silicon PV



Figure 3-13 – Concentrating PV (SGCC)

### 3) Characteristics of PV power generation

One of the key components of PV systems is the inverter. DC output from PV systems is changed into AC by inverters. The performance of the inverter is especially important for grid-connected PV power plants, since it directly influences whether the PV power plant can meet the requirements of grid operation. Most inverters have low voltage ride through (LVRT) and flexible active and reactive power control capabilities. However, since there is no rotating component, PV systems cannot supply inertia support to the power system.

Compared to CSP described below, PV power generation (except for concentrating PV) has the advantage that it can use not only direct sunlight but also the diffuse component of sunlight to generate electricity, which allows its effective deployment in many more regions. Compared to wind power generation, PV power generation is less challenging for grid integration because sunlight is more predictable than wind. Up to now, the comparatively high cost of PV power generation has been the main barrier to its mass deployment [jea11].

#### 3.2.3 Concentrated solar power generation

##### 1) Basics of CSP generation

CSP generation, also known as solar thermal power generation, is much like conventional thermal power generation that converts thermal energy into electricity, but differs in how the thermal energy is obtained. CSP plants use various mirror configurations (with a sun tracking system) to reflect and concentrate direct-beam

sunlight to heat the working fluid flows (such as air, water, oil or molten salt) in the receivers to a high temperature, thus converting solar energy into thermal energy (see Figure 3-14).

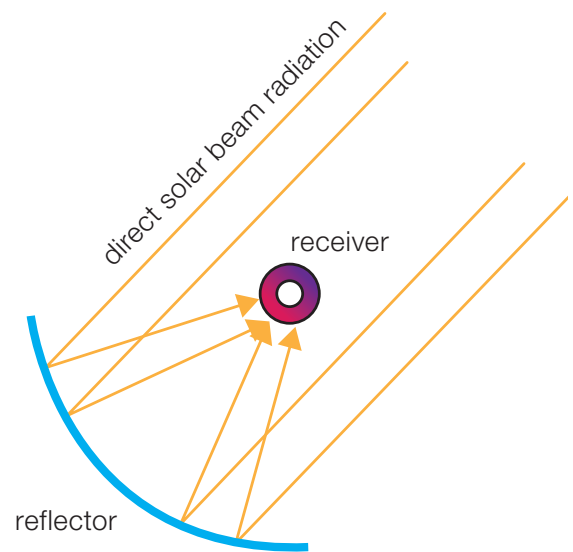

Figure 3-14 – Principle of obtaining thermal energy in CSP

[dlr05]

Using a generator driven by a steam turbine, gas turbine or heat engine, this thermal energy is then converted into electricity. CSP plants may also be equipped with thermal energy storage systems for operating during cloudy periods or at night. A typical stand-alone CSP plant has a configuration such as that in Figure 3-15.



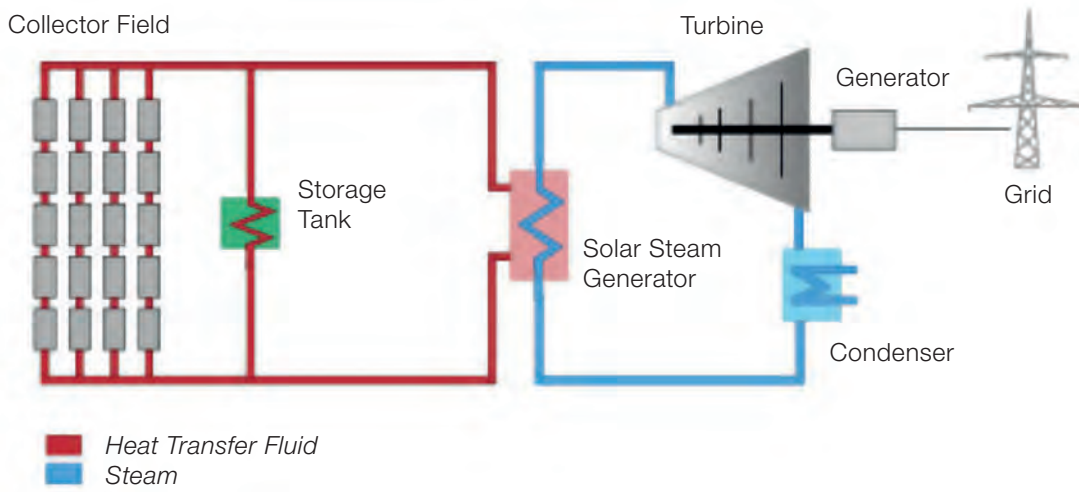

Figure 3-15 – Stand-alone CSP plant  
[gre12]

A CSP plant can also be designed as a hybrid system that uses fossil fuel to supplement the thermal output during low solar radiation periods (see Figure 3-16), making the plant output

more stable and dispatchable. It can also be integrated with a conventional combined-cycle plant to improve energy efficiency.

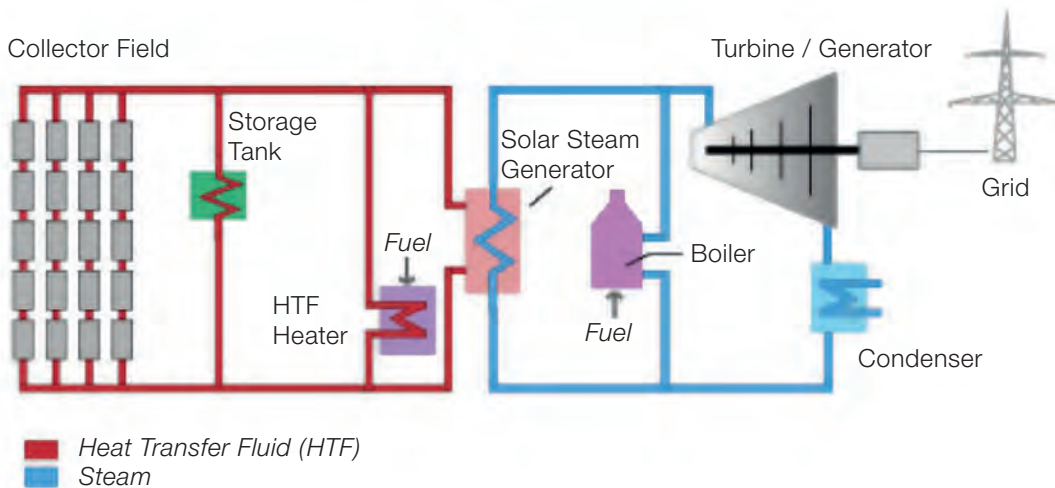
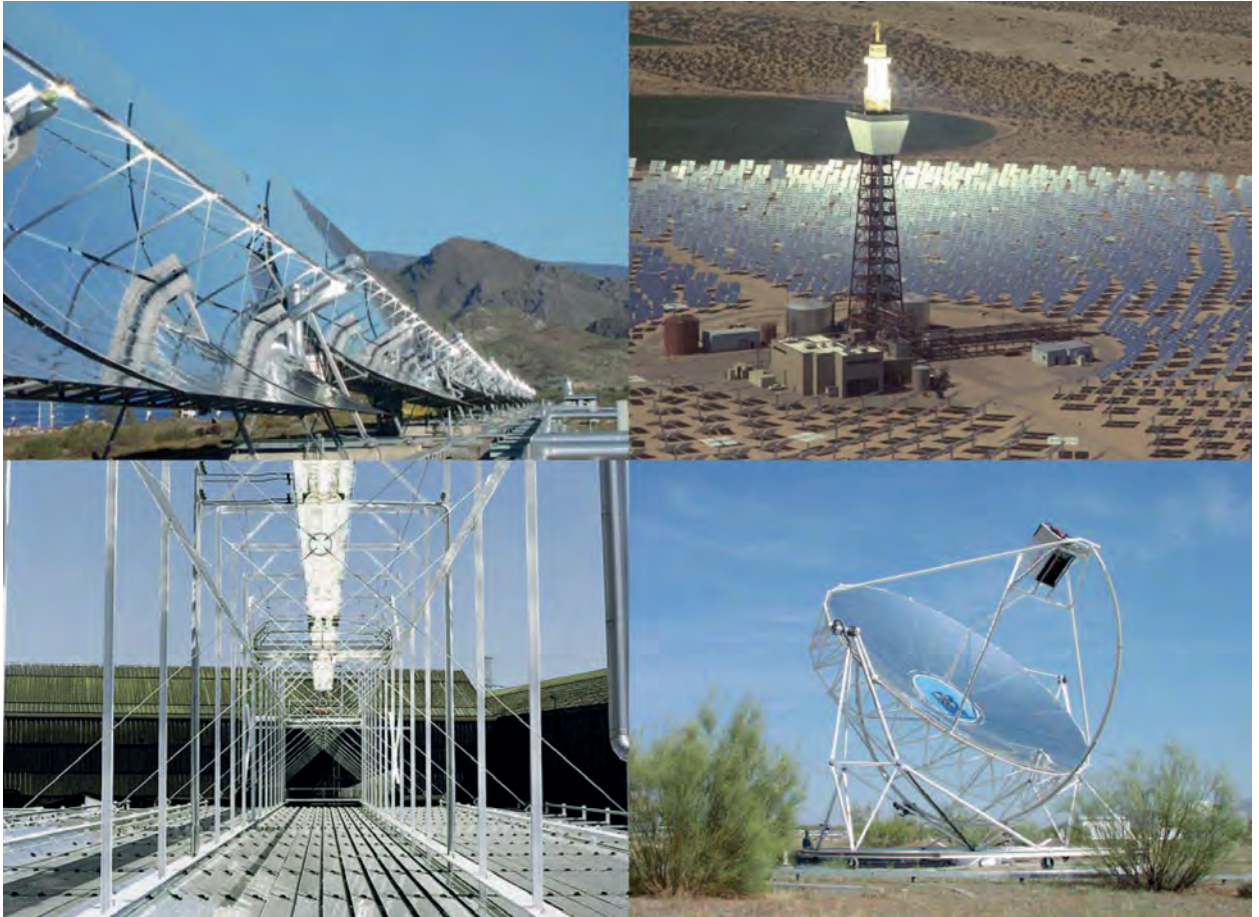

Figure 3-16 – Hybrid CSP plant  
[gre12]



(a) Parabolic trough system  
(b) Linear Fresnel reflector (LFR)

(c) Solar tower  
(d) Parabolic dish

Figure 3-17 – Types of CSP technologies  
[dlr05]

## 2) Types of CSP generation technologies

According to how the solar energy is collected, present CSP technologies can be classified into four major types [dlr05] [hts09] [jea11]: parabolic trough, linear Fresnel reflector, solar tower and parabolic dish systems (see Figure 3-17).

- **Parabolic trough systems** use long rows of parabolic mirrors to reflect and concentrate sunlight beams onto a linear receiver tube that contains the working fluids
- **Linear Fresnel reflector systems** use long rows of flat or slightly curved mirrors to concentrate the sunlight beams onto a downward-facing linear receiver tube fixed in space above the mirrors
- **Solar tower systems**, also known as central receiver systems, use numerous large, flat mirrors to concentrate sunlight beams onto a receiver at the top of a tower
- **Parabolic dish systems**, also known as dish/engine systems, concentrate sunlight

beams onto the focal point of a single dish, where the receiver and an engine/generator (such as a Stirling machine or a micro-turbine) are installed

The capacity of parabolic trough, linear Fresnel reflector and solar tower systems can reach hundreds of megawatts, while the capacity of dish/engine systems is generally in the 10 kW range, suitable only for distributed generation. The solar-to-electricity efficiency of parabolic trough systems has been demonstrated to be about 10 %-15 %, with a perspective of reaching about 18 % in the medium term.

### **3) Characteristics of CSP generation**

CSP is advantageous in that it offers a utility-scale, dispatchable and firm RE option. With the inherent energy storage capability in the form of heat that can be used to generate electricity up to hours later, and with further support from additional thermal storage systems or a hybrid system design, CSP plants can continue to produce stable electricity even when clouds block the sun or the sun sets. So it is much less challenging to integrate CSP than wind or PV generation into power systems.

Although CSP has better performance for grid integration, the relatively immature technology and the high cost are currently limiting its large-scale deployment.

One disadvantage of CSP is that it requires strong direct sunlight. As a result, adequate CSP resources are generally limited to semi-arid, hot regions or deserts. At the same time, like other thermal power generation plants, CSP requires water for cooling and condensation, which means a tremendous challenge in exploiting CSP resources in arid regions. Dry cooling (with

air) is an effective alternative, but with higher costs and lower operating efficiencies.

## **3.3 Transmission technology**

Large-capacity RE generation plants are usually far from load centres, and they therefore need long-distance power transmission. Up to now, AC transmission has been used for large-capacity RE power transmission, and voltage source converter high voltage DC (VSC-HVDC) transmission has been used for offshore wind power integration. Examples will be given in this section. Ultra-high voltage AC (UHVAC) and current source converter HV/UHVDC (CSC-HV/UHVDC) are planned to be used in large-capacity RE power transmission; these will be described in section 4.

### **3.3.1 AC transmission**

AC transmission is a mature technology. The capacity of an AC transmission line is proportional to the square of the voltage level and inversely proportional to the impedance of the line, which increases with the transmission distance. To achieve a large increase in the transmission capacity of long-distance AC lines, a natural way is to raise the voltage level. The approximate transmission capacities and distances of different voltage-level AC lines are listed in Table 3-1 [sgc07]. For small-to-medium scale RE power plants, transmission lines below 330 kV are usually used. For large-scale, long-distance RE power, transmission lines above 500 kV are usually needed. Some examples of AC transmission above 500 kV for RE integration in China and the USA are described below.

Table 3-1 – Typical transmission capacities and distances of different voltage-level AC lines

Voltage level (kV)	Capacity (MW)	Distance (km)
110	10-50	50-150
220	100-500	100-300
330	200-800	200-600
500	1 000-1 500	150-850
765	2 000-2 500	Above 500

### 1) USA

Currently, three major 500 kV transmission projects are under construction or have been approved in Southern California for RE power transmission [ete11], a summary of which is given in Table 3-2.

### 2) China

In November 2010, a 2 398 km double-circuit 750 kV transmission line was commissioned for

the interconnection of the Xinjiang power grid and the Northwest power grid as well as for the transmission of the phase I Jiuquan wind power base. Jiuquan wind power base phase I has an installed capacity of 5 160 MW. A small portion is locally consumed, while most is transmitted to the load centre of the Northwest power grid (see Figure 3-18). A second 750 kV transmission corridor is now under construction. 500 kV transmission lines have also been built for the Jilin wind power base in Northeast China.

Table 3-2 – Three AC transmission projects in California for RE power transmission

Project	RE integration capacity provided by project (MW)	Transmission line length (km)	Purpose
Sunrise Power Link	1 700	196	Enhance grid connection between Imperial Valley and San Diego, transmitting wind, solar and geothermal power from Imperial Valley and Arizona to San Diego
Tehachapi Renewable Transmission Project	5 850	530	Transmitting wind and solar power in Tehachapi area
Colorado River Devers Valley (CDV)	4 700	270	Transmitting wind and solar power in the Blythe area between California and Arizona

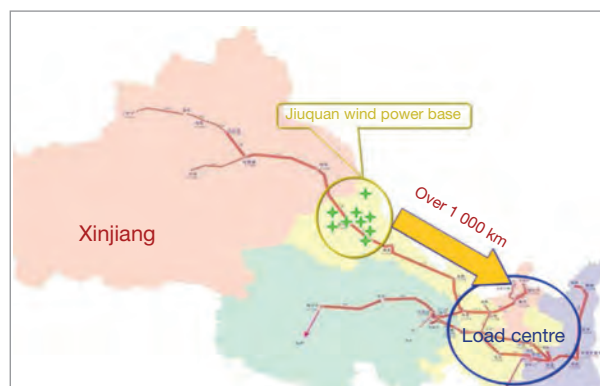

Figure 3-18 – Transmission of the phase I Jiuquan wind power base, Northwest China (SGCC)

### 3.3.2 VSC-HVDC transmission

IGBT-based VSC-HVDC differs from the conventional thyristor-based current source converter HVDC (CSC-HVDC, also known as line commutated converter HVDC (LCC-HVDC)) in that it is self-commutated via control circuits driven by pulse-width modulation, while CSC-HVDC is line-commutated, i.e. switched off when the thyristor is reversely-biased from the AC voltage [wei11]. Compared to CSC-HVDC, VSC-HVDC offers among others the following major advantages [vsc10]:

1) It can rapidly control both real and reactive power, independently, within its rated MVA capacity. As a result, it can transmit very low and even zero active power, which is suited to the frequent and wide-range output fluctuation of RE generation, while CSC-HVDC is limited by minimum startup power. VSC-HVDC terminals can generate or absorb a given amount of reactive power as instructed or according to the voltage level of the connected AC grid, providing excellent voltage support, while CSC-HVDC terminals always absorb reactive power when working, requiring large amounts of reactive power compensation.

2) It can rapidly reverse the reactive power direction merely by reversing the current direction, without changing the voltage polarity as CSC-HVDC requires. It therefore needs no changes in the topology and strategy of the converter station control system.

3) It does not require support from the connected AC grid for commutation as CSC-HVDC does, and can therefore be connected to weak or even passive AC grids, while CSC-HVDC requires the connected AC grid to be sufficiently strong.

Due to these advantages, VSC-HVDC is desirable for RE integration, especially for offshore wind power, as well as for grid interconnection and power supply to isolated systems and to crowded metropolitan areas. The fast development of RE has led to a rapid increase in VSC-HVDC projects in recent years. Some VSC-HVDC projects commissioned for RE integration are listed in Table 3-3. There were also 12 VSC-HVDC transmission projects under construction all over the world at the end of October, 2011. From 2009 onwards, the total capacity of VSC-HVDC projects under construction in the world has reached 10 GW, which is four times higher than that of the projects built before 2009.



Table 3-3 – VSC-HVDC projects commissioned for RE integration

Year	Project	Country	MW / kV / km	Remarks
1999	Gotland	Sweden	50 / ±80 / 70	Onshore wind power integration (voltage support)
2000	Tjæreborg	Denmark	7.2 / ±9 / 4.3	Onshore wind power integration (testing for offshore wind power integration)
2009	Nord E.ON 1	Germany	400 / ±150 / 203	Offshore wind power integration
2011	Shanghai Nanhui	China	18 / ±30 / 10	Offshore wind power integration

### 3.4 Operational technologies and practices

This section focuses on operational technologies and practices related to wind power, since wind power generation is currently the most widely deployed large-capacity RE generation and has significant impacts on power system operations. Much has been done to address these impacts by researchers and grid operators worldwide. Similar technologies and practices can also be used for PV and solar thermal power generation. For the operation of power systems with high penetration of large-capacity RE generation, RE power forecasting is critical for grid operators to carry out operational planning studies and ensure that adequate resources are available for managing the variability of RE output.

#### 3.4.1 Power forecasting

##### 1) Forecasting methods

Based on the time scale of the forecast, wind power forecasting can be classified as ultra-short-term forecasting, short-term forecasting

and medium/long-term forecasting. Short-term forecasting is currently the most widely used, with a time scale up to 48-72h. The principle of short-term wind power forecasting is shown in Figure 3-19. Present methods for short-term wind power forecasting generally include physical methods, statistical methods, and a hybrid of the two.

- **Physical methods** start with a numerical weather prediction (NWP) model, which provides the expected wind speed and direction at a future point in time. Further steps include the application of the NWP model results to the wind farm site, the conversion of the local wind speed to power, and the further application of the forecast to a whole region [ewe05].
- **Statistical methods** first establish the relationship between the historical NWP data and the historical power output data of wind farms via one or more learning algorithms, and then predict the wind farm power output based on this relationship.

The advantages and disadvantages of the two types of method are shown in Table 3-4.

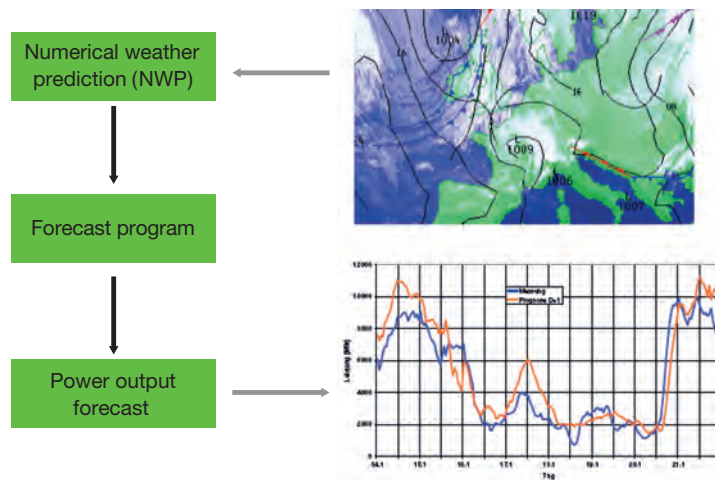

Figure 3-19 – Principle of short-term wind power forecasting (SGCC)

Table 3-4 – Advantages and disadvantages of two forecasting methods

Methods	Advantages	Disadvantages
Physical methods	<ul style="list-style-type: none"> <li>Require no historical power output data for the wind farms; suitable for new wind farms.</li> <li>Based on detailed analysis of each atmospheric process; the forecasting model can be optimized to obtain more accurate forecasts.</li> </ul>	<ul style="list-style-type: none"> <li>Very sensitive to systematic errors caused by incorrect initial information.</li> </ul>
Statistical methods	<ul style="list-style-type: none"> <li>High accuracy can be achieved if high-quality data can be obtained.</li> <li>Self-adjustment can be made to give appropriate output even if the input is not included in the training set.</li> </ul>	<ul style="list-style-type: none"> <li>Require a great deal of highly consistent historical data.</li> <li>Work like a black box, difficult to understand the learning and decision-making process and optimize the model.</li> </ul>

Some of the major short-term wind power forecasting programs available on the market are listed in Table 3-5. Although the current

programs are already able to provide valuable forecast results, further improvement is eagerly expected [ewe05].

Table 3-5 – Overview of short-term wind power forecasting programs

Program	Developer	Methods	Country	Operational since
Prediktor	RISO National Laboratory (DK)	Physical	Spain, Denmark, Ireland, Germany, USA	1994
WPPT	IMM, Technical University of Denmark	Statistical	Denmark (East and West)	1994
Previento	University of Oldenburg and Energy & Meteo System (DE)	Physical	Germany	2002
AWPPS (More-Care)	Armines/Ecole des Mines de Paris (F)	Statistical, Fuzzy-ANN	Ireland, Crete (Greece), Madeira (Portugal)	1998,2002
RAL (More-Care)	RAL (UK)	Statistical	Ireland	--
Sipreolico	University of Carlos III, Madrid; Red Eléctrica de España	Statistical	4 GW, Spain	2002
Local Pred-RegioPred	CENER (ES)	Physical	Spain	2001
Cassandra	Gamesa (ES)	Physical	Spain, Portugal, USA	2003
GH Forecaster	Garrad Hassan (UK)	Physical and Statistical	Spain, Ireland, UK, USA, Australia	2004
eWind	TrueWind (USA)	Physical and Statistical	Spain (represented though Meteosim), USA	1998
HIRPOM	University College Cork, Ireland; Danish Meteorological Institute	Statistical	Under development	--
AWPT	ISSET (DE)	Statistical, ANN	15 GW, Germany	2001
AleaWind	Aleasoft (ES)	Statistical	Spain	2004
Scirocco	Aeolis (NL)	Physical	Netherlands, Spain	2004
Meteorologica	MBB	Physical	Spain	2004
Meteotemp	No specific model name	Physical	Spain	2004
WPFS	CEPRI	Physical and Statistical	China	2009



## 2) Forecast accuracy

The accuracy of wind power forecasting can be measured by different indices. Root mean square error (RMSE) normalized to the installed wind power is most commonly used. Regardless of the forecasting method used, the forecast error (RMSE) for a single wind farm is between 10% and 20% of the installed wind power capacity for a horizon of 36 hours [ewe05].

Spatial aggregation greatly reduces forecast errors, just as it reduces variability. As seen in Figure 3-20, the level of accuracy improves as the size of the region considered for forecasting increases. This is due to spatial smoothing effects. The error reduction shown along the vertical axis in Figure 3-20 is the ratio between the RMSE of a regional prediction and the RMSE of forecasting for a single site, and is based on the measured power production of 40 wind farms in Germany. Aggregation over a 750 km region may reduce forecasting error by about 50% [eis11]. If forecasting is scaled up to apply to the aggregated

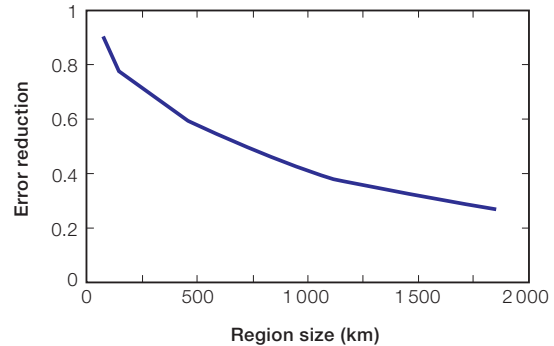

Figure 3-20 – Decrease of wind forecast error for aggregated wind power production [hol09] (energy & meteo systems)

wind power of a large area, the forecast error (RMSE) can drop to below 10% [ewe05].

On the other hand, the forecast error increases as the time horizon of the forecast increases, as shown in Figure 3-21, which also shows the improvement in forecasting techniques over the years. Generally, the error for 1-2 hours ahead for a single farm forecast can be about 5%-7%, and can reach 20% for day-ahead forecasts.

WIND FORECAST EVOLUTION – 2005-2008 (DATA FROM RED ELECTRICA ESPANA)

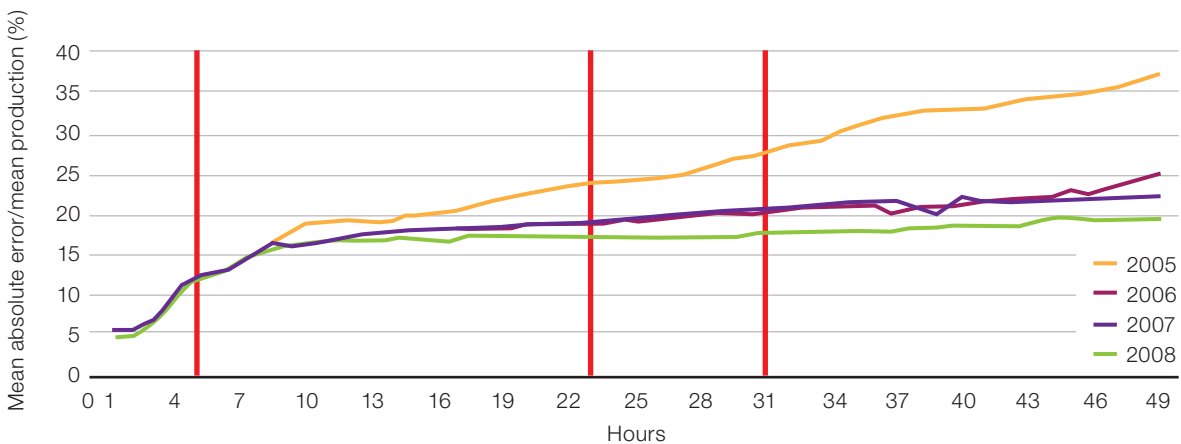

Figure 3-21 – Wind forecast error as a percentage of wind production, as a function of the time forward from the present

[uei10]

### 3.4.2 Operational practices

Due to the differences in RE generation development, the conventional generation fleet, grid structure as well as market and institutional environments, the operational practices related to RE integration are quite different in different countries or regions. Some operational practices related to wind power integration in major countries are briefly introduced below.

#### 1) China

According to the Renewable Energy Law and related regulations, wind power (and other renewables) should be given first priority in generation scheduling and dispatching under normal power system operating conditions. To meet this requirement, grid operators consider predicted wind power generation in the mid-to-long term, day-ahead and intra-day operation planning processes and fully exploit flexibility from conventional power plants, as well as the capacity of inter-grid tie-lines to accommodate the maximum wind power while maintaining system security and reliability (see Figure 3-22) [sgc11] [wei11].

The requirement is also emphasized for WPPs to be equipped with control and monitoring systems; these serve to enhance their controllability and provide operational information to grid operators. To date, all grid-connected WPPs have been equipped with control and monitoring systems that can communicate with the dispatching centres in real time.

Wind power forecasting systems have been deployed in several regional or provincial dispatching centres in the State Grid Corporation of China (SGCC), but only about 30 WPPs have established a plant-level wind power forecasting system, a situation needing to be improved by more stringent management. A SGCC NWP centre has also been established in the China Electric Power Research Institute (CEPRI) to provide weather information needed by the wind power forecasting systems. Based on wind power forecasting at different time scales, a “wind power optimal dispatching decision support system” had been developed and put into operation in the dispatching centre of the Jilin provincial power grid (see Figure 3-23).

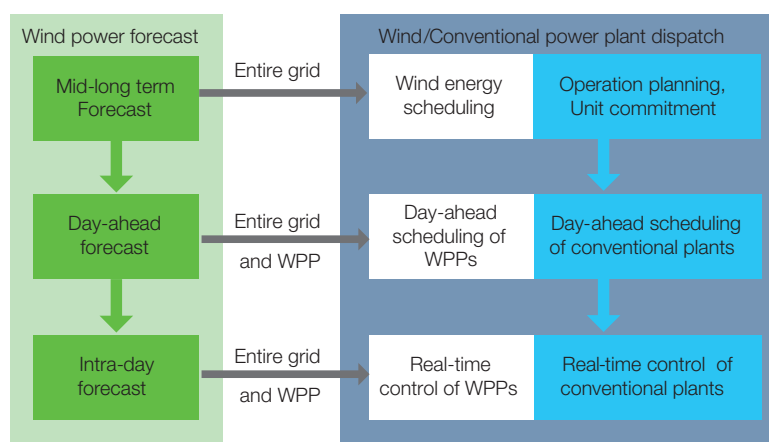

Figure 3-22 – System operation in China taking wind power into account

[sgc11]

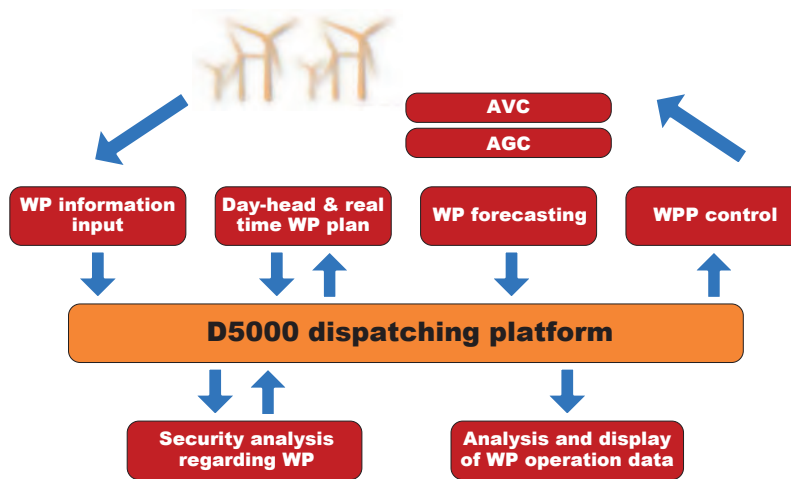

Figure 3-23 – The “wind power optimal dispatching decision support system” in Jilin [sgc11]

## 2) Denmark

Energinet.dk, the transmission system operator (TSO) of Denmark, mainly uses two wind power forecast tools: one external and one internal. The external forecast tool gives a 0-12 hour forecast every 5 minutes and a 0-48 hour forecast every hour. The input to the forecasting includes four different numerical weather predictions. The internal forecast tool includes a 0-6 hour short-term forecast and a 12-36 hour day-ahead forecast.

A well-functioning power market and an automatic dispatching system have been established throughout the north European power system including Denmark, through which the hydropower in Norway and Sweden

is often used to balance the wind power in Denmark. Figure 3-24 shows the monitoring curves of power generation and exchange, where line A is total power production based on individual 5-minute schedules from all power plants, lines B are exchange plans with neighbouring grids (Western part of Denmark (DK1) to SvK in Sweden, DK1 to Tennet in Germany, DK1 to ENDK in Denmark and DK1 to SN in Norway, from top to bottom). In general, the Nordic Power System can be balanced by trading: the additional electricity produced by WPPs is purchased at a low price and sold to the other grids at a higher price. In addition co-generation plants and electric boilers play an important role in winter in balancing the fluctuations caused by large-scale wind power.

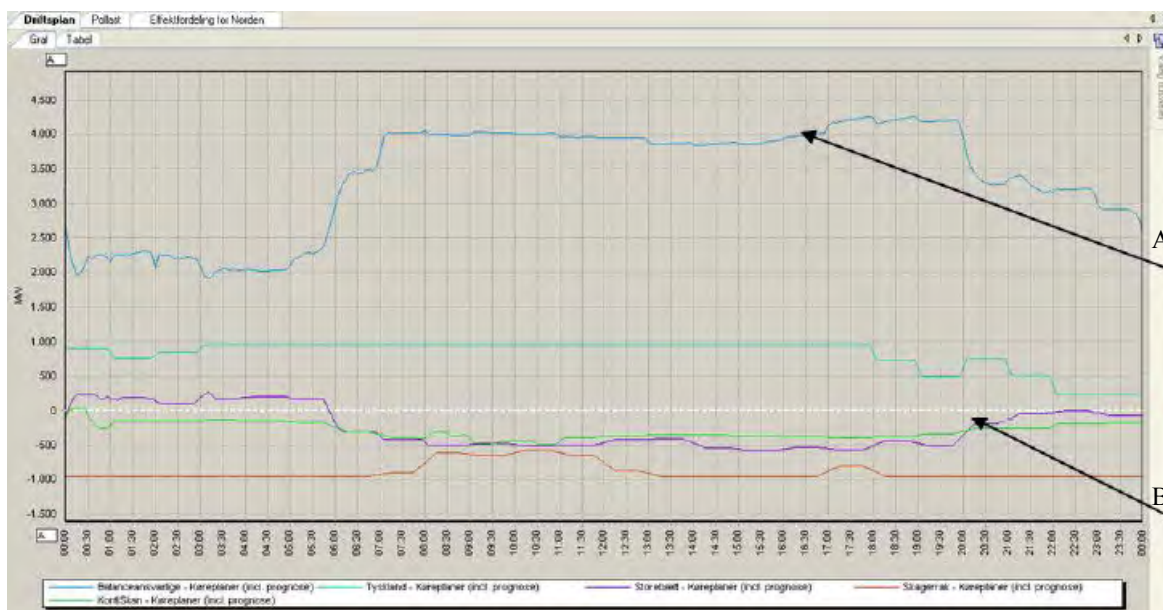

Figure 3-24 – Monitoring power generation and power exchange with neighbouring grids  
[sad11]

### 3) Germany

Three of the four TSOs in Germany (50Hertz, Tennet, Amprion and ENBW) have established wind power forecasting systems, covering approximately 98% of Germany's wind power capacity. For example, the Amprion company has set up a Front Office to manage the operation of the forecasting system and optimize the forecast results by a combination tool (see Figure 3-25). Amprion shares wind power forecasting data (day-ahead and ultra-short-term) with other members of TSC (TSO Security Cooperation).

In September 2004, the German "Renewable Energy Sources Act" amendment introduced a new mechanism for wind power balancing, which requires each system operator to contribute to balancing the whole country's wind power output in proportion to the size of its regional grid.

This mechanism allocates wind power and the associated fluctuation to each system operator in real time. It is more equitable in the distribution of balance services and related costs. The four system operators have developed a real-time wind power monitoring system to determine the wind power balancing capacity that every system operator should be responsible for. In fact, as concerns wind power, the regional grids have integrated into a single large grid in Germany.

In certain areas, the wind power output will sometimes exceed the transmission capacity of the grid, and the grid managers have a legal obligation to increase power transmission capacity. In the interim period before the additional capacity objectives are achieved, the grid managers can require the wind farms to reduce their power output or shut down some of the wind turbines.

### Wind power Prediction - Combination tool

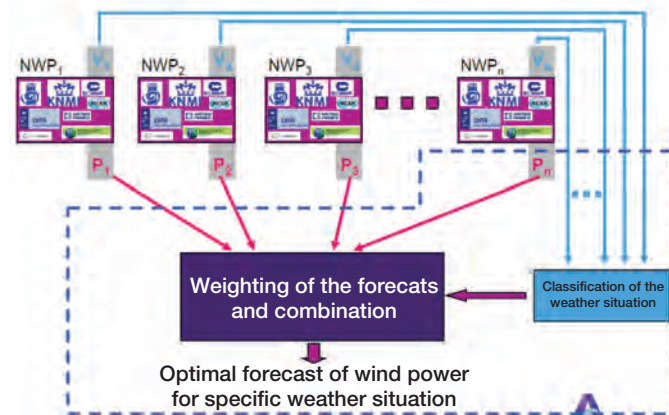

Figure 3-25 – Schematic of a combination tool for wind power forecast  
(Amprion Company)

#### 4) Japan

Japan's power system consists of two parts, the Western 60 Hz network and the Eastern 50 Hz network, which are interconnected through frequency converter stations. The Eastern network consists of three utilities: the Hokkaido Electric Power Company (EP), Tohoku EP and Tokyo Electric Power Company (TEPCO). Hokkaido EP is interconnected with Tohoku EP through DC submarine cables, and Tohoku EP and TEPCO are connected by a 500 kV double-circuit AC transmission line (see Figure 3-26).

The areas suitable for wind power generation are limited by geographical factors, and they are unfortunately concentrated in areas whose system capacities are comparatively small. Most wind resources are located in the smaller Hokkaido and Tohoku EP areas, where peak demand is around 5 GW and 15 GW respectively. In the area of TEPCO, which has an electricity demand of 60 GW including the Tokyo metropolitan area, there are few suitable locations for wind power. This situation poses a challenge for wind power

integration, since the amount of RE that can be integrated into a grid depends on the capacity of the network where the RE is located.

To enhance wind power integration, one option is to use inter-ties between utilities efficiently to balance wind power generation output. In 2010, collaboration schemes were launched by the three utilities for timely sharing of the wind power forecasts in the Hokkaido and Tohoku EP areas, and closely monitoring the power flow of all the inter-ties from Hokkaido EP to TEPCO. If there is room for extra power flow in the inter-ties and other grid conditions permit, wind power generated in the Hokkaido and Tohoku EP areas can be transmitted to TEPCO, with the output of the thermal power plants being reduced accordingly to absorb the incoming wind power. These collaboration schemes will improve the utilities' capability to accommodate wind power, but the capability is limited by the capacity of the inter-ties. When the capacity of the inter-ties is insufficient, excess wind power generation has to be curtailed.

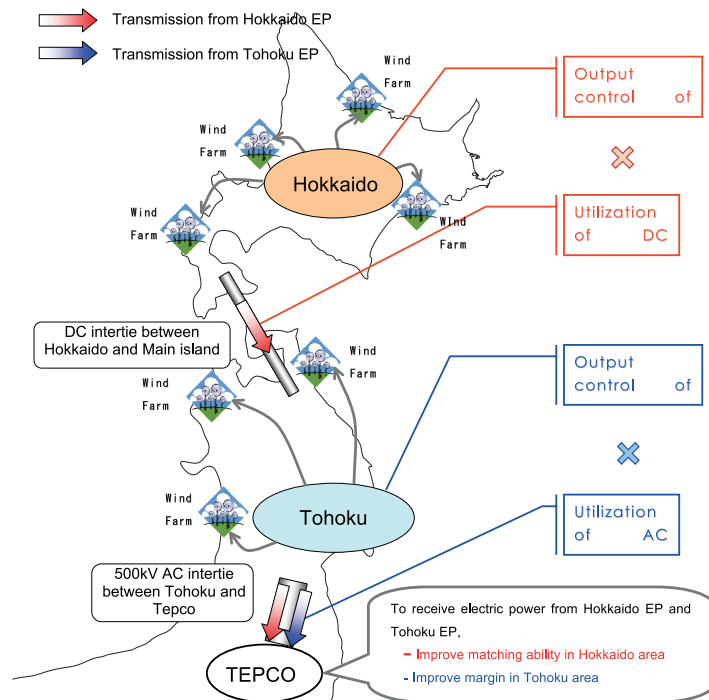

Figure 3-26 – Three utilities in the eastern half of Japan

## 5) Spain

Red Eléctrica de España (REE), the only grid company in Spain, has established the world's first RE power control centre (CECRE in Spanish), which is responsible for scheduling and controlling national RE generation.

Wind farms are also required to set up real-time control centres, and the control centres of the wind farms with an installed capacity greater than 10 MW must connect directly to CECRE, as shown in Figure 3-27. These control centres must be able to control wind power output according to setting values issued by CECRE within 15 minutes at any time. For power system security reasons, if necessary, REE has the right to reduce the wind power output.

CECRE carries out three-phase permanent fault simulation on the 70 different substations' buses every 20 minutes, using an assessment programme named GEMAS (Maximum Admissible Wind Power Generation System). On one hand, it can determine the maximum RE which the entire system can accommodate while still guaranteeing system security. On the other hand, using an optimization method, it can calculate the maximum output of each wind farm. The resulting setting thus calculated is sent by CECRE to every control centre. Figure 3-28 shows typical scheduled and actual wind power output curves in a day.



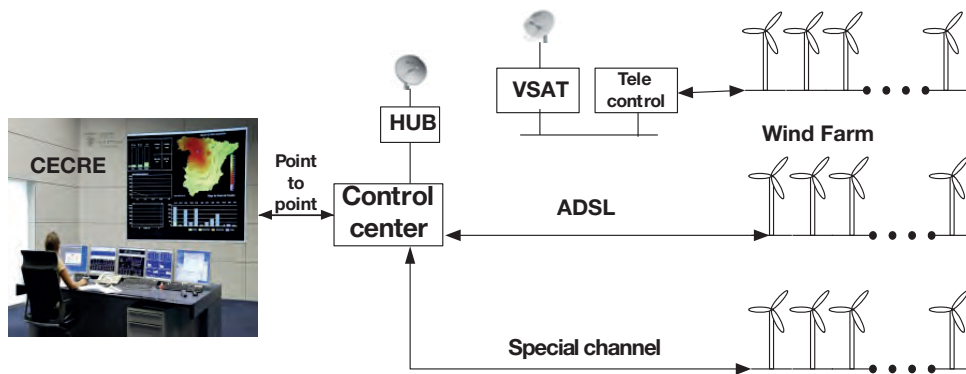

Figure 3-27 – Interconnection between wind farms and CECRE  
(REE)



Figure 3-28 – Scheduled and actual daily curves of wind power output

## 6) USA

Due to different grid composition, rules and wind power penetration, the various regional grids of the USA have developed widely varying wind power scheduling, dispatch and operational mechanisms. For example, the California Independent System Operator (CAISO), as a leader in state-of-the-art mechanisms, has developed a Participating Intermittent Resource Program (PIRP) that allows individual

wind facilities to self-schedule according to shared forecasting technologies. The New York Independent System Operator (NYISO) requires wind farms to behave like conventional power in order to participate in real-time electricity markets: in certain circumstances, the wind farm must reduce output power or be fined if it exceeds the value specified in scheduling instructions.

In the western portions of the USA outside CAISO, which follow reliability standards set by the Western Electricity Coordinating Council (WECC), an even greater degree of diversity is present. Because of a lack of organized, open electricity markets, the WECC is primarily managed by vertically-integrated investor-owned utilities (IOUs), federally owned power marketing administrations (PMAs), and municipal and rural utilities that primarily purchase power at wholesale to serve local loads. Each utility has its own scheduling and dispatch procedures according to the peculiarities of its generation mix, and energy trading between utilities is difficult and dominated by long-term power-purchase agreements. Nevertheless, many utilities

integrate renewables into day-ahead, hour-ahead, and real-time scheduling procedures, much like the open markets of the Eastern Interconnect and the CAISO. Rule changes are underway in the WECC, and utilities with higher proportions of renewable power are pressing for more robust energy imbalance markets in order to ease RE integration costs. Though it is the least-organized of US power markets, the WECC is of critical importance to the USA due to its high resource concentrations of RE and the presence of very large federal PMAs such as the Western Area Power Administration (WAPA) and the Bonneville Power Authority (BPA), which are under the direction of the US Department of Energy.



# SECTION 4

**Future: technical solutions  
for integrating more  
large-capacity RE**

### 4.1 General

As we have seen, integrating more large-capacity RE into the grid brings variability and uncertainty. At the same time, there will continue to be unexpected disturbances stemming from load variation, grid faults and conventional generation outages. Worldwide studies and experience in recent years have shown that new technical solutions are needed to address this conjunction of difficulties. The new solutions will include new technologies, methods and practices, applied in order to provide more flexibility and improve the efficiency of power systems, constantly balancing generation and load. Only this will make the power systems reliable and maintain security of supply, i.e. avoid any interruption in the supply of power.

The required power system flexibility can be achieved on the generation side, from both RE generation and conventional generation. It should first be pursued using *grid-friendly RE generation*. This means mitigating the impacts of

RE generation on the power system, enabling it to contribute to system reliability and stability by improving its design and control technologies. However, the amount of flexibility which can be achieved by this approach is limited. Flexibility from conventional generation is currently the major source of power system flexibility, and is generally referred to as “*generation flexibility*”.

Flexibility can also be achieved from the load side through *demand response*, and from *energy storage* that can act as either generation or load (see Figure 4-1). In addition to adding new flexibility, existing flexibility can be better exploited by *operational enhancement* within a balancing area, and can be shared in wider geographic footprints by cooperation between, or consolidation of, smaller balancing areas, supported by *transmission expansion*.

The application of energy storage to support large-capacity RE integration will be discussed separately in section 5, while the other solutions mentioned will be discussed in this section.

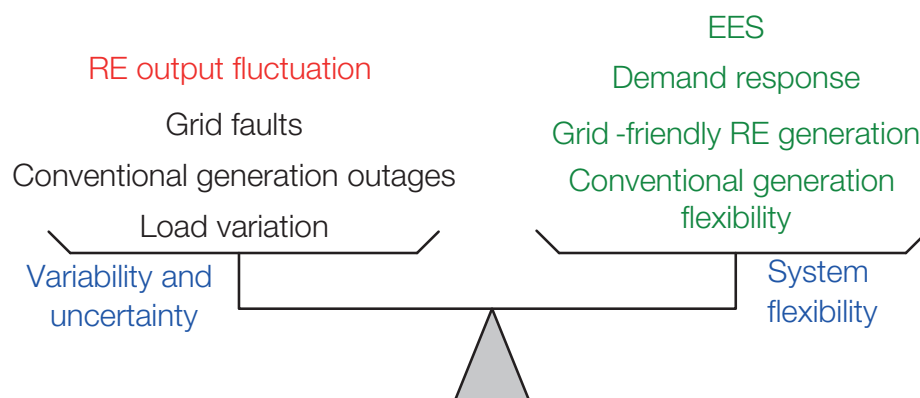

Figure 4-1 – System flexibility vs. variability and uncertainty  
(SGCC)

## 4.2 Grid-friendly RE generation

### 4.2.1 Need for grid-friendly RE generation

At the beginning of its development RE generation technology focused more on tapping the maximum power from RE resources. It neglected to make any contribution to power system reliability and stability and in the absence of standards and incentives was not designed to operate in a coordinated fashion with the rest of the system. As long as RE penetration is low this is manageable and can be accepted by power system operators. But as RE generation penetration grows, and especially as the capacity of RE power plants becomes larger and larger, this will have a serious impact on system operation.

For example, in 2011 several serious wind turbine disconnection incidents occurred in China due to the lack of fault ride-through capability (see 4.2.2), including one at the Jiuquan wind power base on February 24, which led to the disconnection of 598 wind turbines from the grid (840.43 MW of power output) and a significant frequency drop.

Therefore it is becoming increasingly important that RE generation should play a greater role in helping to maintain system reliability and stability, and this may be increasingly required by interconnection standards. Technologies have been developed and are continuously improving at the generating unit, plant and plant cluster level to make RE generation more predictable, controllable and dispatchable, or in other words more grid-friendly.

### 4.2.2 Advanced characteristics of RE generating units and plants

Development of power electronics and mechanical engineering technologies, as well as the design of proper control strategies, have enabled wind generating units to possess performance comparable or even superior to those of conventional thermal or hydro generating units. Some advanced operational capabilities of wind generating units and the methods to achieve them are cited below from [ner09] and [bac11] with minor modifications. Most of these capabilities can also be achieved for solar PV generating units since they share many technical characteristics with wind turbine generators, especially the inverter-based ones.

#### 1) Voltage/Var control and regulation

Reactive power support and power factor control can be provided either through a built-in capability (available for wind generating units types 3 and 4) or through a combination of switched capacitor banks and power electronic based transmission technologies such as static var compensator (SVC) and static synchronous compensator (STATCOM) (flexible AC transmission system (FACTS) equipment as discussed in 4.4.2, applicable to all types of wind generating units).

#### 2) Fault ride-through

The ability is needed to survive (ride through) specific low and high voltage/frequency ranges and durations caused by faults or disturbances in the power system. Voltage ride-through can be achieved with all modern wind generating units, mainly through modifications to the controls. In some cases, with older type 1 or type 2 wind

generating units at weak short-circuit nodes in the transmission system, there may be a need for additional transmission equipment.

### 3) Active power control, ramping and curtailment

This can be achieved through unit control mechanisms for wind turbine units with active-stall or pitch control, or discrete tripping of units.

### 4) Primary frequency regulation

Primary frequency regulation can be supplied by all units that are equipped with some form of pitch regulation (i.e. active-stall or pitch control).

### 5) Inertial response

Inertial response is inherent in type 1 and type 2 units, and can be achieved through supplemental controls in the converter to emulate inertial behaviour for type 3 and type 4 units.

### 6) Short-circuit current control

All inverter-based variable generators have a built-in capability to limit the fault current to a level that does not exceed 150% of the full load current.

For grid integration it is important to view RE generation at the plant level. An RE power plant is not just a simple collection of RE generating units, but is also supported by many other components and systems so as to function like a conventional power plant. Based on advanced generating units, these characteristics can also be achieved at the plant level. Plant-level reactive power compensation, accurate RE generation output forecasting, the presence of monitoring, control and data communication systems, as well as properly designed relay protection schemes all help to improve the predictability, controllability and dispatchability of RE power plants. An example of the typical structure of a “grid-friendly” wind power plant is given in Figure 4-2 [sge11].

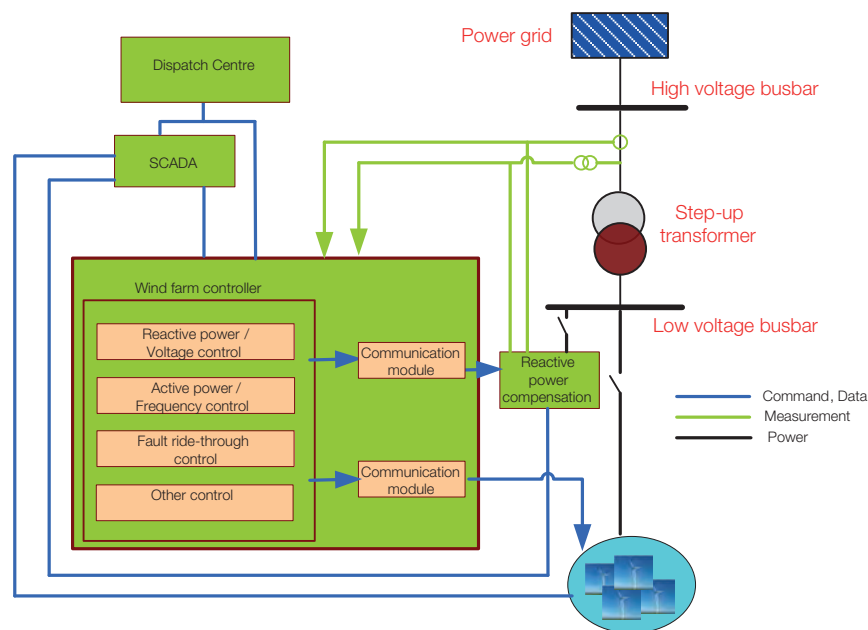

Figure 4-2 – Typical structure of a “grid-friendly” wind power plant (SGCC)

### 4.2.3 Centralized control of an RE plant cluster

The areas with the best RE resources may see the development of RE power bases with many RE power plants located adjacent to each other. A schematic diagram of the Jiuquan Wind Power Base in Northwest China is given in Figure 4-3 as an example. It is organized in several layers: arrays of wind turbine generators form a wind power plant, several plants are connected to a 330 kV collection substation through 35 kV lines, and several collection substations are further connected to a final 750 kV integration substation through 330 kV transmission lines of tens of kilometres. In other words, a large-capacity RE power base may consist of several RE plant clusters.

The control of the RE power plants in such a cluster must be coordinated if operational problems are to be avoided. Taking reactive

power control as an example [pei12]: with multiple wind plants having requirements to provide reactive power and control grid voltages, problems have emerged when the voltage and reactive power controllers in nearby plants have been incompatible, resulting in poor voltage control and counterproductive reactive power flows. There have been numerous reports of one or more plants at maximum reactive power output while neighbouring plants are absorbing reactive power. To avoid this kind of situation, centralized cluster control is an attractive solution. A centralized cluster control system, configured in a multi-layer structure such as that depicted in Figure 4-4, can be used to coordinate the active and reactive power control of a RE power plant cluster, just as cascaded hydro power plants on a river are controlled. Such a centralized cluster control system, the so-called Large Wind Power Plants Cluster Active Power Intelligent Control System, has been developed and deployed at the Jiuquan Wind Power Base [sgc11].

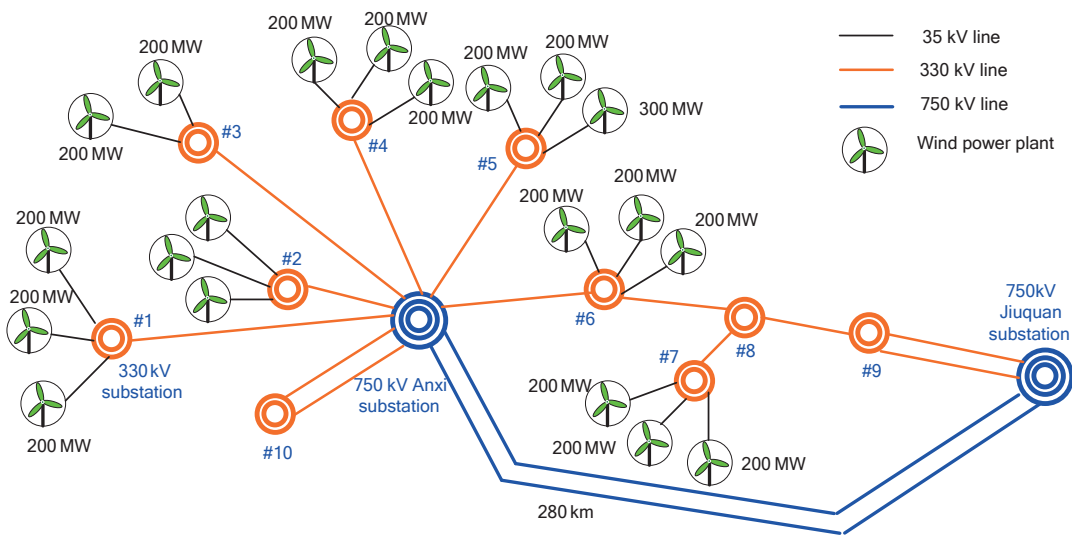

Figure 4-3 – Schematic diagram of the Jiuquan Wind Power Base, Gansu, China (SGCC)

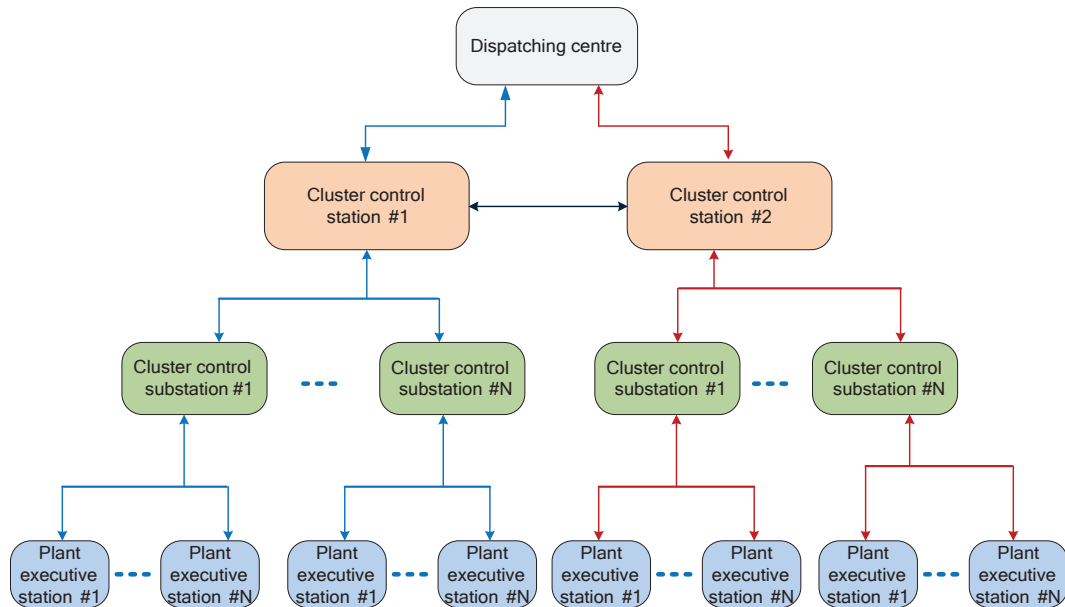

Figure 4-4 – RE power plant cluster control system structure (SGCC)

#### 4.2.4 Improvements in modelling RE generation

In order to represent accurately the static, dynamic as well as short-circuit performance of RE generators, plants and clusters and their impacts on power systems, appropriate models of the different types of RE generation are needed.

Up to now, most RE generation modelling efforts have been carried out at the generator level [aba11] [bac11] [mma11]. Although RE generator manufacturers have long been developing and refining models to improve their generator design – these are typically user-written proprietary models on commercial software platforms – it has now been recognized that publicly available industry-standard models, similar to those available for conventional

generation, are needed for planning studies. Significant progress has been made towards industry-standard models by the task forces or working groups under WECC, the Institute of Electrical and Electronics Engineers (IEEE), the Utility Wing Integration Group (UWIG) and the North American Electric Reliability Corporation (NERC), with the development and distribution of generic dynamic models for wind turbine generators. These are models with general model structures that allow for representation of wind turbine generators of the same type, regardless of manufacturer, by selecting appropriate model parameters. WECC and IEC groups are moving forwards to refine and validate these generic models, for which collaboration between the power engineering community and wind turbine manufacturers is necessary. Efforts to develop generic models for PV have also begun. However, regarding RE

generator modelling, a great deal of research still needs to be carried out, e.g. to determine the short-circuit contribution of different types of RE generators, and to represent the more advanced and rapidly developing control characteristics of RE generation, such as those described in 4.2.2.

IEEE and IEC groups have started to expand efforts in generic dynamic modelling for entire wind power plants, including control and auxiliary equipment [mfc11]. Modelling of large-scale wind power plants is particularly challenging due to the fact that they may consist of tens or even hundreds of individual generators, distributed over the large footprints of the plants, and the requirement of being represented as a single equivalent unit in power system simulations for simplicity. Techniques are needed to aggregate the individual generator models while considering the spatial and temporal interaction among the generators. Techniques are also needed to represent all the cables connecting all the generators as a single equivalent circuit, and to test the validity of the equivalent model as a whole. Extending this modelling work to huge clusters of wind power plants, such as the 10 GW-scale wind power bases in China, will be even more difficult.

## **4.3 Improved flexibility in conventional generation**

### **4.3.1 Need for more flexibility in conventional generation**

Although system flexibility can also be achieved through demand response and energy storage as well as through grid-friendly RE generation, it may take decades for low-cost, large-scale

storage to mature (with the exception of the widely used but topographically restricted pumped hydro storage), and demand response as a flexibility resource is still in its infancy. Flexibility in conventional power plants (generally referred to as “generation flexibility”) is therefore the major source of power system flexibility, and “the need for increased generation flexibility is central to the challenges posed by intermittent renewables” [eis11]. The need for generation flexibility differs in different countries and regions due to their different existing generation mix.

Generally, hydro power plants with a reservoir are most flexible, followed by gas-fired power plants, then coal-fired power plants and last nuclear power plants, but it is difficult to measure flexibility so as to allow use of the measurements in generation planning.

### **4.3.2 Assessment of generation flexibility**

#### **1) Flexibility of conventional power plants**

The relevant technical characteristics of conventional power plants that contribute to operational flexibility are the cycling, ramping and partial loading capabilities. Cycling capability is a generator’s ability for frequent and fast startup or shutdown. Ramping capability is the rate at which a generator can change its output, either upwards or downwards. Partial loading capability is the minimum output level at which a generator can be stably operated, as well as the efficiency when operating at different output levels lower than rated capacity. Due to the differences in design and technology, different types of power plants have different levels of operational flexibility, implying varying impacts on equipment health, service life, operational costs and GHG emissions.



**Hydro power plants** with reservoirs are very flexible in operation. They can be easily and quickly started up or shut down with little impact on equipment health or service life. They can start from off-duty status and ramp to full-loading status in several minutes, and change their capacity by 50% in fractions of a minute. Their minimum output can be very low, which means a regulation range of near 100% capacity. However, output and hence the flexibility contribution of hydro power plants can be influenced by seasonal factors (drought and flooding seasons) as well as non-electricity-sector requirements such as flood and drought control or environmental and navigational considerations.

**Gas-fired power plants**, including natural gas combined cycle (NGCC) and simple cycle gas turbine (SCGT) plants, are also flexible generation resources. Current designs of SCGTs in operation are able to ramp to 100 MW-150 MW in 10 minutes, and NGCC plants in 60 to 80 minutes. New NGCC designs with an increased focus on the ability to operate in a system with a large proportion of intermittent

renewables are expected to produce 150 MW in 10 minutes and to ramp to full load in 30 minutes. The ramping rate of NGCC and SCGT plants is generally up to 8% per minute. NGCC plants can reduce their output to 80% of capacity with only a minimal heat rate penalty, but with increasing efficiency losses at lower outputs [eis11].

**Coal-fired power plants** have limited operational flexibility. They are not suitable for frequent cycling since they may take several hours to start up or shut down. Their ramping rates are generally only 1%-3% per minute; new large-capacity generators can reach 5% per minute. Their minimum output is generally 70%-80% of capacity; new large-capacity or specially designed peaking generators can go down to 50% or lower, but lower output will lead to higher fuel consumption per kWh generated. An example is given in Table 4-1 [npg10]. The flexibility of specific coal-fired power plants can be influenced by their size, age, operating pressure, fuel quality and the control systems installed [eis11].

Table 4-1 – Standard coal consumption of typical 600 MW and 1 000 MW generators at different loading levels

Loading level (% of rated capacity)	Standard coal consumption (g/kWh)	
	1 000 MW ultra-supercritical generators	600 MW ultra-supercritical generators
40 %	306	311
50 %	298	303
75 %	287	290
100 %	282	284

**Nuclear power plants** also have limited operational flexibility and are less used for ramping for economic reasons. Relatively new nuclear reactors can down-ramp 20% of total output within an hour, but require six to eight hours to ramp up to full load. Nuclear plant ramping operations are not fully automated, creating opportunities for operator error. Although operational costs for nuclear plants running at partial load versus full load do not significantly differ, they need to run as base load units at high output levels to recover their high capital costs [eis11].

With more large-capacity RE generation being integrated into power systems, not only the flexible hydro and gas-fired power plants are required to adjust their output more frequently, the coal-fired and nuclear power plants traditionally operated mainly as base load units are also shifting to more flexible operation paradigms. Much effort is needed to better understand the impact of flexible operation on the technical, economic and environmental performance of conventional power plants, especially thermal power plants, hence to support the improvement in equipment design, retrofit and daily operation, as well as the design of necessary financial incentives.

## **2) Measuring generation flexibility**

The need for more generation flexibility is well recognized. However, there is currently a lack of metrics, methods and tools to measure the flexibility and its related cost of provision, determine the flexibility required, and optimize the generation resources to provide the required flexibility with minimal cost, all of which would be needed to support the planning and operation of power systems with more large-capacity RE. It is much more difficult to measure generation flexibility than to

measure the adequacy of generation capacity; the former is more complicated and requires more data and detailed modelling [trp11]. Collaboration between grid operators and the research community is desirable to foster efforts to develop more rigorous methods and tools to accurately quantify, monitor and assess the degree of flexibility in a given power system for a given level of RE penetration [sad11].

The research community has started to respond to the need for power system flexibility measurement. The emphasis is on generation flexibility, currently the major flexibility resource, but efforts also include using demand response and energy storage for flexibility. The Integration of Variable Generation Task Force (IVGTF) under the NERC in 2010 released a special report on the flexibility requirements and metrics for variable generation [ner10], which discussed the metrics and approaches for flexibility measurement. The IEA Grid Integration of Variable Renewables (GIVAR) project has proposed a semi-quantitative method supported by qualitatively described limiting constraints on flexible resources to assess system flexibility, and a subsequent project specially targeting the quantification of system flexibility is expected [fat11]. The Alberta Electric System Operator (AESO) has developed a dispatch decision support tool, incorporating wind power forecasting, to measure system flexibility and help operators to manage the increased variability and uncertainty [pao11].

### **4.3.3 Generation planning for both adequate capacity and adequate flexibility**

In power systems with higher variability and uncertainty due to the integration of more

large-capacity RE, it is becoming increasingly important for the generation planning process to consider not only the adequacy of generation capacity, but also the adequacy of generation flexibility. Simply having a specified number of megawatts of capacity may not be adequate for system security if that capacity is not flexible enough to respond to system variability [aba11].

### 1) Planning for adequate generation capacity

For capacity planning, the calculation of the “capacity value” (also known as “capacity credit”) of RE generation has been recognized as a major issue. The capacity value of a generation resource can be defined as the amount of additional load that can be served due to its addition while maintaining existing levels of reliability. The calculation of the capacity value of RE generation is much more difficult than that of conventional generation due to its inherent variability and uncertainty. Research on this issue has received much attention. Both the IEEE Power & Energy Society (PES) and the NERC IVGTF have established task forces to study it. A rigorous “effective load-carrying capacity” (ELCC) method based on reliability simulation as well as several approximate methods have been proposed for wind power capacity value calculation, and are being extended to solar power. But there remain a number of problems, including the representation

of other types of generation in the calculation, the accuracy of approximate methods and the requirement of high-quality wind, solar and synchronized demand data for the ELCC method to produce reliable results [bac11] [cvw11].

### 2) Generation planning considering flexibility at the system level

In order to consider flexibility requirements, a new paradigm of generation planning is needed. One example is the approach proposed in [trp11], adding a flexibility assessment stage into the planning process, as shown in Figure 4-5.

It starts from the relatively simple traditional capacity adequacy calculation, using metrics such as loss of load expectation (LOLE) and expected unserved energy (EUE), to form an initial generation portfolio, and then moves to the more data-intensive system flexibility assessment and production cost simulation stages. Both of these stages involve computation-intensive unit commitment and economic dispatch studies. This three-stage approach is designed to reflect the aims of the planning process, i.e. to provide a reliable, operable, least-cost generation portfolio for the given study period. If excessive or inadequate flexibility is observed, the generation portfolio or unit commitment model can be altered and the whole process iterated, in order to find a better generation portfolio that meets

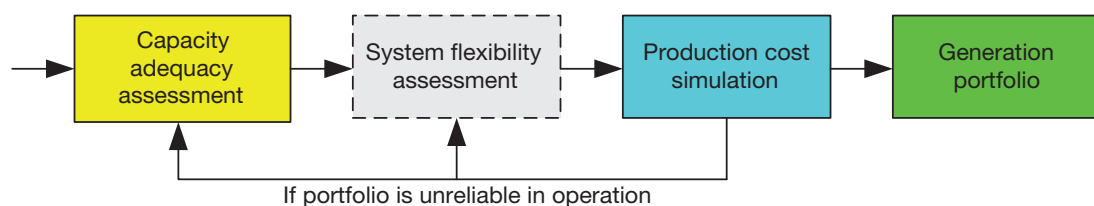

Figure 4-5 – Generation planning process incorporating flexibility assessment

[trp11]

the dual aims of minimizing cost and meeting a specified flexibility standard.

Again, the system flexibility assessment is possible only when metrics measuring flexibility in the planning context are available, which is currently not the case. A good start is the metric named “insufficient ramping resource expectation” (IRRE) developed by the IEA, which applies principles similar to those underlying the LOLE metric for capacity adequacy calculation.

### **3) Generation planning considering flexibility at resource site level**

Besides incorporating flexibility considerations into generation planning at the system level, special designs can also be used at resource site level to exploit the flexibility of conventional generation in order to compensate for the variability and uncertainty of RE.

Such an approach is intended for some wind power bases in China, where the so-called “wind-fire bundling” design has been proposed (see Figures 4-9 and 4-10): coal-fired power plants are planned near a wind power base and will share its transmission lines. Wind power output fluctuations can be smoothed out by adjusting coal-fired production; thus the utilization of the transmission line can be improved as compared to transmitting only wind power and the average cost of electricity at the receiving end can be reduced [sgc11].

## **4.4 Transmission expansion**

### **4.4.1 Needs for transmission expansion**

Accommodation of large-capacity RE generation needs large-scale transmission

grid expansion and reinforcement for the following reasons:

1) Grid expansion and inter-regional connection are needed to transmit the energy generated by large-capacity RE sources, which are generally located far from load centres and the existing grid.

2) Through grid expansion, the geographic diversity of RE generation can be exploited to smooth out their aggregated variability and uncertainty and to reduce the RE power forecast error.

3) Grid expansion and reinforcement can support interconnection between balancing areas, hence facilitating their cooperation or consolidation to share flexibility resources.

As shown in [smp11], transmission for RE integration is an issue everywhere for both technical and regulatory reasons. An inability to solve the transmission problem will jeopardize the achievement of RE goals, and drive up the cost to reliably integrate these new resources into power systems.

### **4.4.2 Application of new transmission technologies**

#### **1) Higher voltage level AC transmission: UHVAC**

UHVAC transmission lines with rated voltage levels of 1 150 kV or 1 000 kV were built and commissioned by the former Soviet Union and Japan in the 1980s and 1990s, but then operated at a 500 kV voltage level for practical reasons. China is now leading the research and application of 1 000 kV UHVAC transmission, which seems a desirable technology to meet the need for large-scale, long-distance power transmission from the

large coal, hydro, wind and solar energy bases in the northern and western regions to the central and eastern regions with huge and still fast-growing electricity demand. The first 640 km single-circuit Jindongnan-Nanyang-Jingmen 1 000 kV UHVAC test and demonstration transmission project was commissioned in 2009, the reinforcement which followed was completed at the end of 2011, and it can now transmit 5 000 MW of power stably. Some UHVAC projects have been planned to form part of the large-capacity, long-distance wind power transmission installation from the West-Inner Mongolia and Hebei wind power base in Northern China [sgc11]. UHVAC has also attracted attention from other emerging large economies facing similar energy delivery challenges, such as India [tea07].

A single-circuit 1 000 kV AC line can transmit 4 000 MW to 5 000 MW over an economic distance of 1 000 km to 1 500 km. Compared to 500 kV AC transmission, 1 000 kV AC transmission has many advantages in improving transmission capacity and distance, reducing power loss, reducing land use and saving cost, as shown in Table 4-2 [sin06] [tgy06]. For RE energy transmission, UHVAC is mainly suitable for transmitting power from on-shore RE plants using overhead lines.

## 2) More flexible AC transmission: FACTS

Based on advanced power electronic technologies and innovative designs, FACTS equipment can

be applied to improve the capacity, stability and flexibility of AC transmission, making it more capable of transmitting large-capacity RE. For example, thyristor controlled series compensators (TCSCs) can be installed in transmission lines to reduce electrical distance, increase damping and mitigate system oscillation; SVC, STATCOM and controllable shunt reactors (CSRs) can be shunt-installed on substation buses to solve the reactive power compensation and voltage control problems which are common in RE integration due to their output fluctuation. SVCs or STATCOMs may also be used to improve the performance of RE power plants to meet integration requirements on reactive power and voltage control, while keeping the design of RE generators relatively simple.

It was noticed when studying the integration of the Jiuquan wind power base in Northwest China that the large wind power output fluctuations would cause large voltage fluctuations in the whole network, especially at the nodes in the transmission corridor. To stabilize voltage, many voltage-regulating devices must act frequently and in a well-coordinated way, which is harmful for the equipment and difficult to implement. In order to solve this problem, a 750 kV CSR was installed on the Dunhuang substation's 750 kV bus (see Figure 4-6), with field testing completed at the end of 2011. Developed by CEPRI, it has a capacity of 300 Mvar and 4 controllable grades: 100%, 75%, 50% and 25%; the adjustment range is 25%-100%.

Table 4-2 – Comparison between 1 000 kV and 500 kV AC transmission: gain factors

Item	Typical capacity	Economic distance	Power Loss	Corridor width per kW	Comprehensive construction cost per kW
1 000 kV/500 kV	4~5	1.5~2	1/4	1/3	<3/4



Figure 4-6 – 750 kV CSR at the Dunhuang substation, NW China (SGCC)

### 3) Higher voltage level DC transmission: UHVDC

CSC-HVDC is a conventional HVDC transmission technology that is relatively mature and has long been used for long-distance, large-capacity power transmission without midway drop points, as well as for the interconnection of asynchronous power networks. Compared to AC transmission, it has advantages such as lower loss, lower line cost, narrower corridor and rapid power control capabilities. Like AC transmission, DC transmission is also progressing in the direction of ultra-high voltage levels for larger-capacity and

longer-distance power delivery. Again, China is leading in the application of ultra-high voltage DC (UHVDC) transmission. The 1 907 km, 6 400 MW,  $\pm 800$  kV UHVDC demonstration project from Xiangjiaba to Shanghai was commissioned in April 2010. SGCC has planned to build more than ten  $\pm 800$  kV or  $\pm 1 100$  kV lines to transmit power from the wind power bases in Xinjiang, Gansu and Inner Mongolia to the Northeast-Central China load centres, ranging in length from 1 600 km to 2 700 km [sgc11], as shown in Figure 4-7.

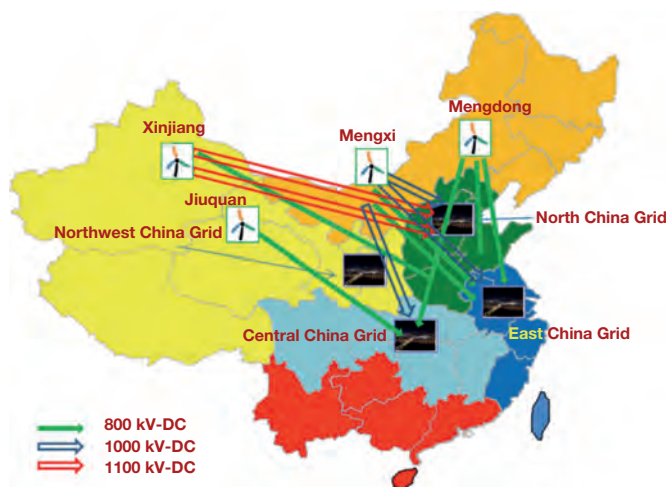

Figure 4-7 – UHVDC transmission plan for some 10 GW-level wind power bases in China (SGCC)



However, there are still some problems in the use of CSC-HVDC or UHVDC to transmit RE [hsh12]. For example, when HVDC lines are used to transmit only wind power to load centres (see Figure 4-8), not only the low utilization rate problem mentioned in 4.3.3, but also the minimum startup power of the HVDC lines and problems in frequency stability and voltage stability require more research.

The “wind-fire bundling” design (see Figure 4-9) can withstand common wind disturbances,

but if wind speeds change rapidly frequency is difficult to control. Without strong voltage support, outages on the sending end may lead to voltage collapse and disconnection of wind generators, depending on the electrical distance between coal and wind power plants.

With voltage support from the local AC grid (see Figure 4-10), the stability problems can be mitigated, but attention should be paid to the impact of wind power fluctuation on the local grid.



Figure 4-8 – Design for transmitting wind power only with HVDC (SGCC)

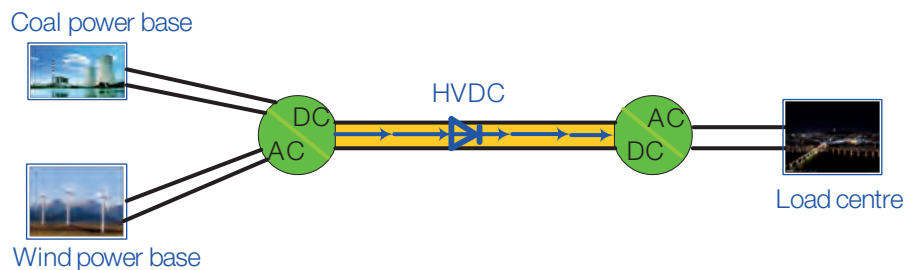

Figure 4-9 – “Wind-fire bundling” design with HVDC transmission (SGCC)

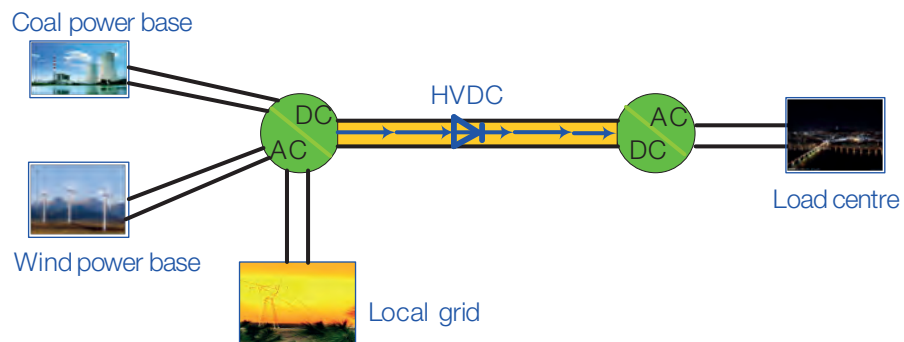

Figure 4-10 – “Wind-fire bundling” design with HVDC transmission and local grid (SGCC)



#### 4) More flexible DC transmission: from VSC-HVDC to MTDC and DC grids

The major advantages of VSC-HVDC as compared to conventional CSC-HVDC described in 3.3.2 make it not only suitable for application in RE integration, but also more convenient to form multi-terminal DC (MTDC). Three or more converter stations are linked to each other with DC lines, each interacting with an AC grid, which facilitates flexible multi-grid interconnection and even DC grids. These will be useful in future RE integration where multiple resource sites and multiple receiving ends are involved.

The preference for VSC-HVDC for relatively long-distance offshore wind power integration is presented in Figure 4-11. It is clear that for short distances and relatively low power high voltage alternating current (HVAC) technology will suffice. As power as well as distance increases, HVAC should be augmented with FACTS devices in order to compensate for HVAC losses and to provide stability support. In order to connect remote offshore wind power plants to a grid, VSC-HVDC technology is preferred.

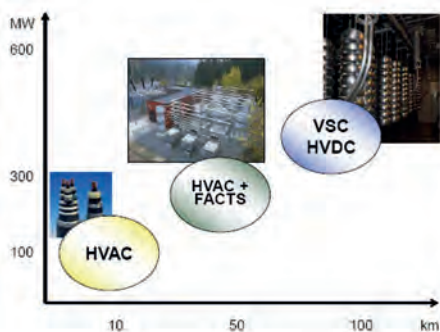

Figure 4-11 – Transmission technologies for integrating offshore wind power [ern11]

In order to tap large quantities of offshore wind power from the North Sea, a *transnational offshore grid* based on multi-terminal VSC-HVDC has been proposed. A simulation benchmark test system has been developed to facilitate detailed investigations into operational questions, as shown in Figure 4-12. Study results show that extensive coordination of control systems is essential, both in order to avoid unwanted DC loop flows and to find the location of the optimal slack node in the system, which also depends on the selection criteria chosen [coc11]. Multi-terminal VSC-HVDC has also been adopted in the design of the Tres Amigas Super Station project proposed in the USA to interconnect its Eastern, Western and Texas power grids, as well as to fully exploit the abundant RE resources near the project site [ete11] [tgs12]. In EU's Super Grid plan, MTDC and DC grids based on VSC-HVDC technology will also play an important role.

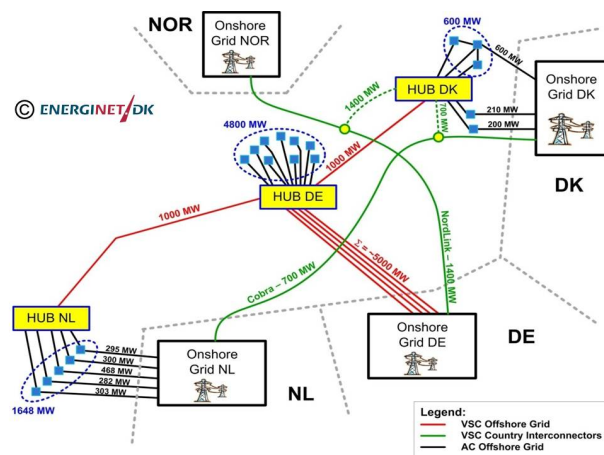

Figure 4-12 – Benchmark test system for the European transnational offshore grid [coc11]

To date, VSC-HVDC has not reached voltage or capacity as high as CSC-HVDC, and VSC-HVDC terminals also suffer from higher power loss. VSC-HVDC transmission with voltage levels less than  $\pm 150$  kV and capacity less than 200 MW is relatively mature. VSC-HVDC transmission projects with voltage levels of 350 kV and capacity of 400 MW have been commissioned, but they are still much smaller than recent  $\pm 800$  kV, 6 400 MW CSC-HVDC projects. The power loss in a VSC-HVDC converter station is typically 1%-6% currently, much higher than the 0.5%-1% loss of a CSC-HVDC converter station. Predominantly VSC-HVDC installations use cables as the transmission medium, although a 350 kV VSC-HVDC using overhead lines has been commissioned by ABB in Namibia at the Caprivi Link. One of the limits imposed on the power transfer capability of a VSC-based HVDC system lies in the capability of DC power cables. Predominantly DC power cables are used with VSC-HVDC connections to help ease right-of-way discussions, and they are the only option for offshore VSC-HVDC connections. However, with the option of overhead lines for VSC-HVDC, power levels can increase as VSC technology advances. Finally, since most VSC-HVDC projects have been operating for only a few years, the overall long-term security and reliability of VSC-HVDC also remain to be proved over time, as with any new type of technology.

#### 4.4.3 Developments in transmission planning

##### 1) Current practice in transmission planning

Up to now, transmission planning has mainly been based on expert judgment

and *deterministic simulations* based on *mathematical models* of the power network and its components. For one scenario of load forecast and generation portfolio for the year studied, transmission alternatives are first proposed by planning experts, then extensive simulations are performed, including power flow, stability and short-circuit studies, among others, under typical normal and contingency situations (generally “worst cases”), to verify whether the deterministic planning criteria can be met. If not, modifications are made to the alternatives and simulations are re-run. For technically viable alternatives, economic comparisons may be made to find the best one. In some cases, in order to account for uncertainty, several scenarios of load forecast and generation portfolio may be considered as a so-called “sensitivity analysis” or “scenario method”.

##### 2) Towards probabilistic transmission planning

The necessity of probabilistic transmission planning has been acknowledged in the research and industry community, following the realization that deterministic planning methods may not be able to reflect the probabilistic nature of outage and system parameters, and that the widely used *N-1* security criterion may be insufficient to capture the real “worst case”, for which a corresponding risk analysis is necessary. As the separation of generation and transmission planning resulting from power market restructuring has made deterministic transmission planning less meaningful, the increasing uncertainty introduced by large-capacity RE integration is making the need for probabilistic transmission planning more urgent [bac11] [mit11] [pts11].

Rather than replacing traditional deterministic transmission planning, probabilistic planning is called to complement it by adding probabilistic planning criteria and evaluation in the planning processes, as shown in the conceptual flow chart in Figure 4-13.

Probabilistic planning criteria, tools and techniques have been developed for

probabilistic transmission planning over the past several decades; however, they will require critical review for completeness and applicability before they can become accepted by industry. More research on additional probabilistic planning techniques is required. High-quality, high-resolution datasets of RE generation are also necessary; they are currently very limited and difficult to obtain [ner09].

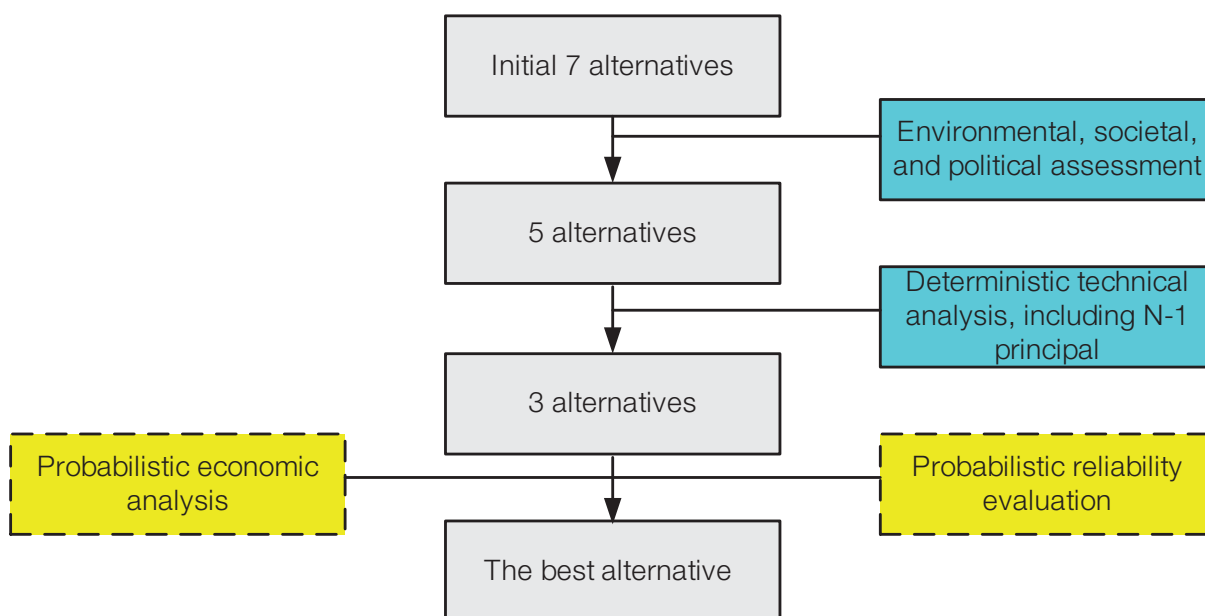

Figure 4-13 – Conceptual flow chart of probabilistic transmission planning [pts11]

## 4.5 Operational enhancement

### 4.5.1 Need for operational enhancement

When resource capacity and flexibility as well as transmission availability have been determined by the planning process, it is operations' responsibility to manoeuvre all the system capabilities to cope with the variability and uncertainty resulting from the integration of large-capacity RE generation. The operations process, as a broad concept distinct from planning, can be further divided into scheduling, dispatch and control processes (see Figure 4-14).

The operation of modern power systems is supported by a physical layer supervisory control and data acquisition (SCADA) system

and an application layer energy management system (EMS). The SCADA system covers most of the spread-out elements in a power system, with sensors to monitor their operational conditions and report them to the operations centre through communications channels. The EMS residing in the operations centre exploits the information collected by the SCADA system to analyze the situation and reveal any problems in the power system, make security and economic dispatch and control decisions, and send real-time commands to control the relevant system elements through the SCADA system. Since modern power systems rely heavily on computerized communications and control for operations, they have evolved into cyber-physical systems.

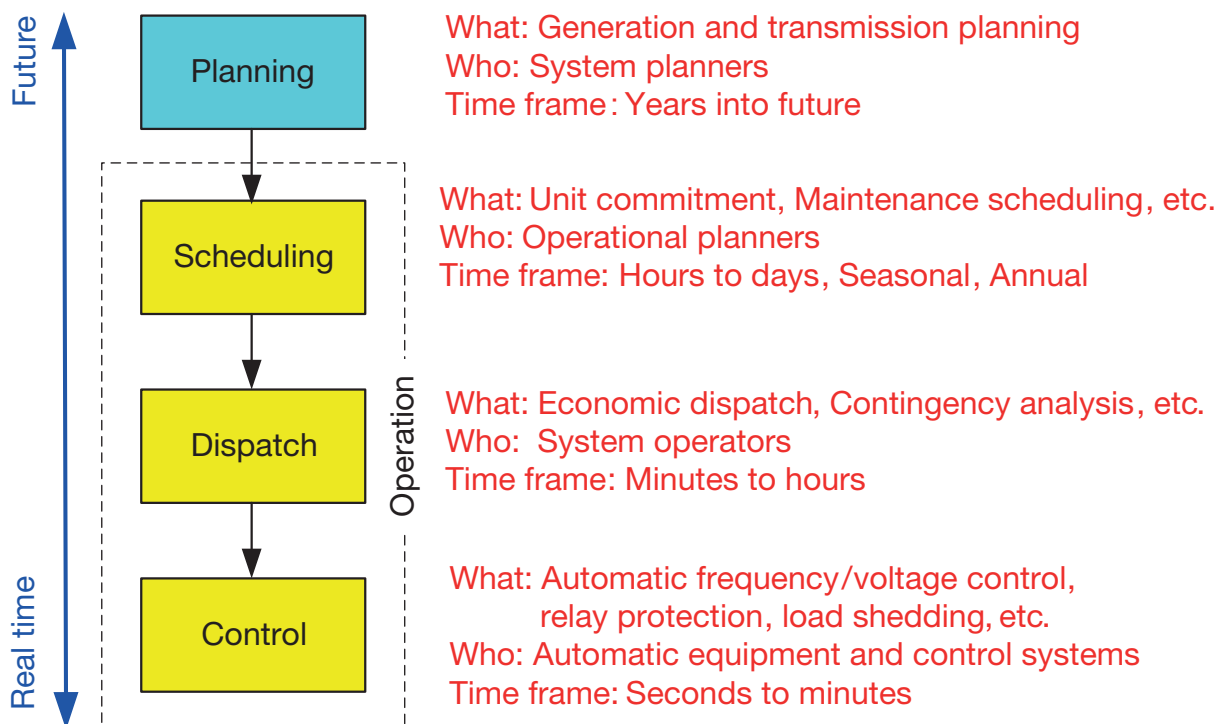

Figure 4-14 – Typical processes of power system planning and operation  
(SGCC)

Historically, various operational tools (EMS applications) have been developed and deployed to successfully address the existing variability and uncertainty in power systems. As variability and uncertainty increase substantially due to the integration of large-capacity RE generation, enhancements have to be made to major operational tools as well as some operational practices; the development and incorporation of more accurate RE power forecasting is critical to most of these enhancements. The integration of large-capacity RE generation may also pose more challenges to cyber-security.

#### 4.5.2 More accurate RE power forecasts

As described in section 3.4.1, many wind power forecast methods and programs have been developed in the last two decades, and the forecast accuracy has been significantly improved, especially for short-term forecasts. However, the forecast accuracy is still low as compared to load demand forecasts, especially for day-ahead and longer time horizons. In addition, the need to forecast significant weather events and provide probabilistic information along with forecast results is not well addressed. Listed below are some directions for improving forecast accuracy and the value of forecasting in operations [atp11] [ner09] [pei12] [sad11].

##### 1) Model and data improvement

Improvements in atmospheric observation and numerical weather prediction models are critical for improving RE power forecast accuracy; here, a promising avenue is collaboration among related sectors at national and international levels to improve boundary-layer weather forecasts. Collection and processing of high

quality meteorological and electrical data from RE power plants, both historical and real-time, is also essential, and for this purpose four-dimensional data assimilation technology may play an important role.

##### 2) Centralized forecast and ensemble forecast

Centralized forecasting at system level can improve forecast accuracy as compared to plant-level forecasts, thanks to the spatial smoothing effect mentioned in section 3.4.1. It is also beneficial for error reduction that the single centralized forecasting system should receive input data from several commercial forecast providers and combine them to form a single ensemble forecast.

##### 3) High-resolution plant-level forecast and nodal injection forecast

While centralized forecasting is the best approach for system-level forecasts, high-resolution separate forecasts at different RE power plants are also very important for RE generation dispatch, and for determining the power injected into each delivery node in the power system for managing transmission congestion.

##### 4) Ramp events forecast and situational awareness

Forecasting of ramp events, sudden and large RE generation output changes caused by severe weather events, is of great importance to provide situational awareness to grid operators and help decision-making. However, the definition and forecast methods of ramp events need more research before ramp event forecasts can be integrated into forecasting products.

### 5) Human forecast

System operators may become good human forecasters after accumulating years of experience. They sometimes outperform advanced forecasting tools. More research is needed into how best to combine human forecasts with computed forecasts.

### 6) Probabilistic forecast

By providing not only the value but also the probability of expected RE power production or ramp events, probabilistic forecasts could become very valuable for system operations.

#### 4.5.3 Enhancement of operational tools and practices

Power system operation is the field that sees the most prominent and direct impacts of large-capacity RE integration. Many aspects of enhancements to operational tools and practices have been discussed in the literature [coc11] [ner09] [opp11] [sad11] [sin12]. Briefly cited below are some major enhancements related to EMS applications. The underlying principle behind these developments is to improve operators' situational awareness by evaluating potential events and their impacts, and to provide operators with guidance on possible mitigating measures.

#### 1) Unit commitment

Detailed unit commitment (UC) studies are normally conducted one day ahead, to determine what amount and types of conventional generation units should be available at what time to ensure the desired generation capacity, and also enough flexibility to address system variability and uncertainty. With increased levels of RE generation it is recognized that UC will

not be effective unless the RE power forecast is taken into account, and that it should be run more frequently, say every 4 to 6 hours or at even shorter intervals, or alternatively each time a new RE power forecast is provided.

#### 2) Contingency analysis

Contingency analysis (CA) assesses the impacts of potential contingencies, which are normally outages of different grid components, under certain operating conditions. With increased levels of RE generation, the contingency set must be augmented to include those extreme ramp events which are due to RE and outages of RE power plants. Information from the RE power forecast is needed to determine potential contingencies.

#### 3) Online dynamic security analysis

Online dynamic security analysis (DSA) has been implemented in many power system control centres to help operators make the right operational decisions. It evaluates system security and stability limits based on near-real-time network topology and operating conditions, such as the transmission line thermal limits and the system voltage/transient/frequency stability. By incorporating the RE power forecast and modelling, an online DSA system can be adapted to cope with the operational risks and challenges resulting from increased levels of RE generation. As an example of such a tool, the wind security assessment tool (WSAT) implemented in EirGrid's control centre (see Figure 4-15) is used to assess the instantaneous secure amount of wind generation based on voltage stability analysis (VSA) and transient stability analysis (TSA) under normal operating conditions and credible faults.

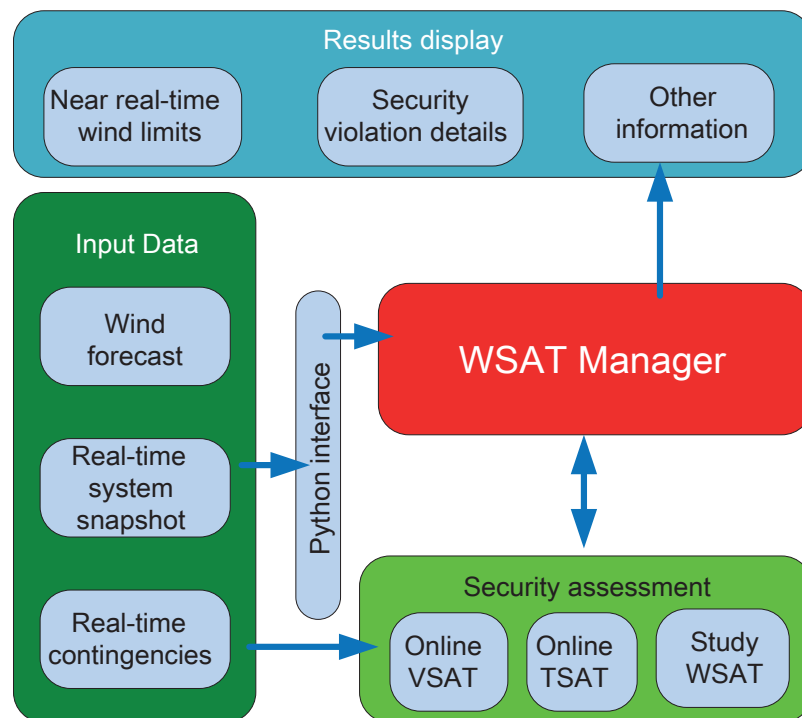

Figure 4-15 – Wind Security Assessment Tool (WSAT) structure  
[sin12]

#### 4) Security constrained economic dispatch

Security constrained economic dispatch (SCED) determines how to dispatch generators to produce electricity at the lowest cost subject to reliability requirements and operational limits on generation and transmission facilities. It is now evolving to accommodate two major directions of power system development: the increase in high penetration RE generation and the development of demand response and smart grid applications (see 4.6). As described in 4.3, more flexibility is needed from conventional generation to integrate high levels of large-capacity RE generation, and the increased ramping and cycling requirements of thermal power plants will lead to a significant increase in their operational costs. These costs have to be better understood before they can

be taken into account to improve the economic dispatch process.

#### 5) Automatic generation control

AGC is a centralized system designed to ensure real-time generation/load balance and frequency stability, by regulating the power output of selected generation units and exchanging power on tie-lines between different power systems or control areas. Existing AGC algorithms need to be modified so that, based on RE power forecasts, they may address the variability and uncertainty of RE generation. There is also an increasing requirement to regulate the output of RE power plants in addition to that of conventional generation units, based on the advanced control capabilities and the monitoring, control



and data communication systems for RE power plants described in section 4.2.

### **6) Stochastic operations and risk-based decision making**

To address the increased uncertainty, including that related to RE power forecasts, many researchers believe that future EMS applications should make greater use of stochastic modelling techniques. Stochastic UC, stochastic SCED and stochastic optimal power flow, for example, should be feasible by taking advantage of the greater computing power now available. Risk-based decision making techniques are also needed to improve the current deterministic and binary decision-making process; for this, research on how to quantify the relevant operational risks and the severity of contingencies such as extreme ramp events is critical.

### **7) Security and defence generally**

“Security” in DSA and SCED (see above) mainly refers to the physical aspects of power system security, or security of supply. As a cyber-physical system, the power system also faces cyber-security challenges, including the reliability of the communications systems serving the power system, and protection of critical information related to power system monitoring and control as well as confidential customer information [top12]. Failures in cyber-security, especially those caused by malicious cyber attacks on the control system, may damage power system elements and endanger the physical power system’s security of supply. Since large-capacity RE power plants are usually remotely located and consist of many widely-distributed, small-capacity

generating units, the cyber-security of their control systems may require more attention. Although substantial efforts have been made by some organizations to address control system security, such as the power system data communication standard protocols developed by IEC Technical Committee (TC) 57 and widely used in power equipment, SCADA and EMS, cyber vulnerability is still a salient problem, and is becoming even more complex with the development of smart grids [iig12] [sic12].

Moreover, as power systems, meteorological systems, communications networks, water, commerce, etc., the so-called “critical infrastructures”, become more closely integrated, it becomes increasingly important that the security protocols in one sector are considered within the broader context of the security protocols in connected sectors, as well as the security needs of the country and region. This issue involves harmonization of cyber-security policies both vertically (e.g. from system operation down to individual wind turbine control) and horizontally (e.g. from the power grid to emergency services and telecommunications). With regard to RE integration, this would suggest a need for integrated security policies between weather forecast systems and power system operation, specifically dispatch. For example, a highly secure power grid system with high RE concentrations could still be quite vulnerable to an attack that targets the country’s weather forecasting service, either disrupting forecasting or providing false forecast data. A grid operator who relied on such data might find himself in serious trouble, beyond simple variations in forecast.

## 4.6 Demand response

### 4.6.1 Demand response applications for RE integration

Demand response (DR), the development and extension of traditional demand-side management or load management practices, is recognized as a key application of the smart grid. Currently the USA is far in the lead in research and application of DR, with Europe, China and other countries catching up [jef11]. The US Federal Energy Regulatory Commission's (FERC) definition of DR is: "Changes in electric use by demand-side resources from their normal consumption patterns in response to changes in the price of electricity, or to incentive payments designed to induce lower electricity use at times of high wholesale market prices or when system reliability is jeopardized" [adr11]. While this definition covers well the current DR practices in the USA, it may not be able to reflect DR's evolving capabilities, including those expected to support RE integration.

As RE penetration rises, DR's value as an additional source of power system flexibility to compensate for the variability and uncertainty of RE generation will increase. For example, REE (Spain) created a demand-side management department in 2007 in order to promote demand management mechanisms such as interruptible service, electric vehicle integration, smart metering and time-of-use tariffs. These mechanisms, used together, are expected to enhance the ability of the system to integrate increasing quantities of RE [coc11]. DR can help RE integration in two main ways, load shifting and balancing.

#### 1) Load shifting

DR can be deployed to transfer a part of the load to off-peak periods to absorb excess

RE generation, particularly for wind power generation, which often exhibits inverse-peaking characteristics: generating more power during off-peak periods and less power during peak demand periods. At off-peak periods, conventional generation plants are often already reduced to their minimum output, and the insufficiency in demand will make wind power curtailment inevitable, reducing wind power plants' capacity utilization efficiency and preventing the replacement of fossil-fuelled power generation for emission reduction. Shifting load to off-peak periods also brings additional energy efficiency and cost benefits for customers. For example, Denmark has implemented zero- and negative-spot electricity prices to encourage customers to use electricity during hours of excess wind generation, and has planned for increased integration between the transport, heating and electricity sectors to find new sources of off-peak load for wind energy [coc11].

#### 2) Demand-side balancing services

Fast-acting DR can be deployed to help balance generation and load in real time. Loads can be aggregated and directed to respond very quickly and therefore be capable of following the fast ramps of RE generation, reducing the need for ramping capability from conventional generation [ded10]. Some system operators are already using DR to counter down-ramps of RE generation, showing flexibility potentially equal to conventional generation options. But different types of load have different response capabilities and different costs of response, and more research is needed to identify the true aggregate value and capability of DR in this area [ner09].

#### 4.6.2 Demand response practices and trends

The practices of DR vary not only among different countries due to differences in electricity markets, technological development and goals for deploying DR, but also inside the boundaries of certain countries. The leading DR programmes in the USA can generally be classified into two categories: dispatchable programmes and reactive programmes [mit11].

**a) Dispatchable programmes**, also known as *load management* or control programmes, allow direct control of load responses by the grid operator or a third-party aggregator. An incentive is often offered to customers in return for participation.

**b) Reactive programmes** rely on customers' voluntary responses to a variety of signals communicated to them. The most common signal used at present is price, although other types of information, such as environmental

signals or neighbourhood-comparative data, may prove useful in the future. Reactive programmes can further be divided into *wholesale programmes* administered by independent system operators (ISOs) and regional transmission organizations (RTOs), and *retail programmes* that present customers with retail prices carefully determined by specific time-varying pricing structures.

Each of the dispatchable, wholesale and retail reactive programme categories consists of several types of programmes, as shown in Figure 4-16. According to a recent survey [adr11], they respectively contributed to approximately 62%, 27% and 8% of the nation's potential peak load reduction (aggregate load enrolled in DR programmes). Although dispatchable programmes still represent a high proportion of enrolment, the advent of smart metres, which allow for two-way information flows between customers and utilities, has enabled the growth of reactive programmes and increased engagement with residential and commercial customers.

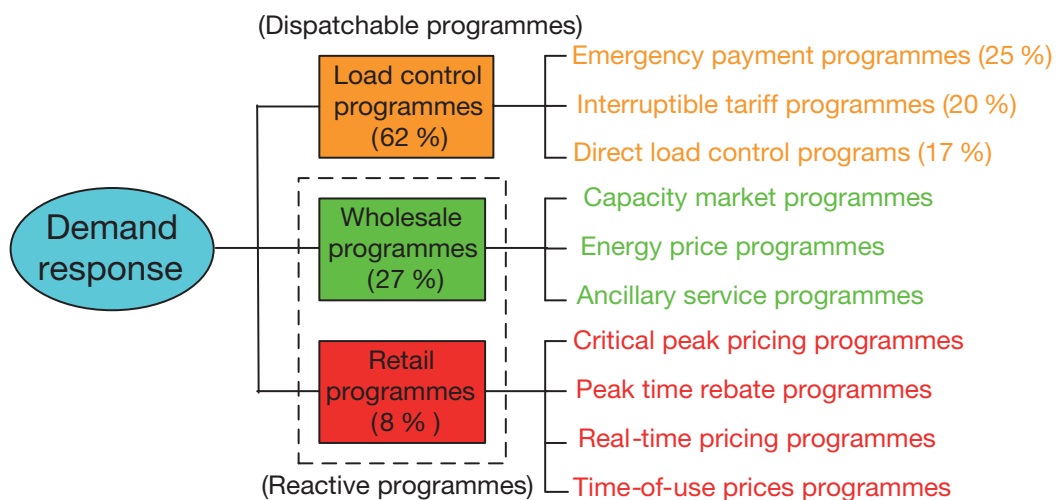

Figure 4-16 – Types of DR programmes in the USA  
(SGCC)

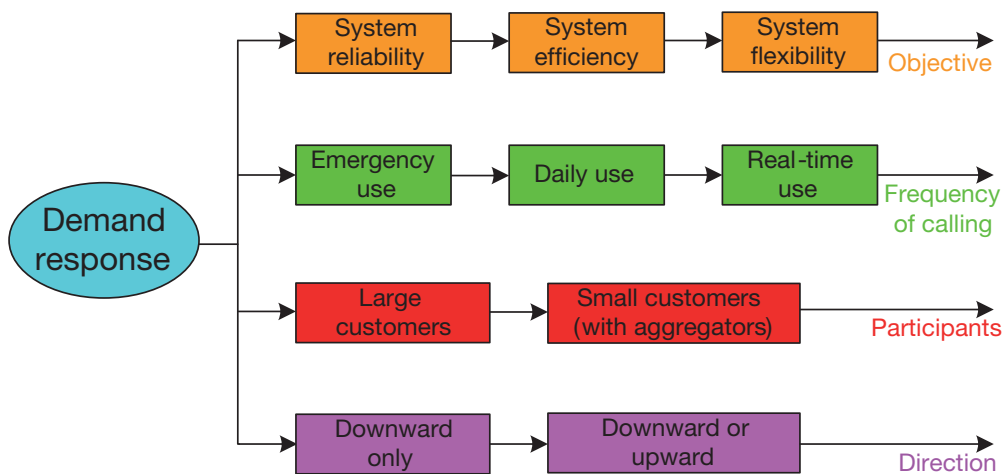

Figure 4-17 – Trends in DR development (“extending” rather than “replacing”) (SGCC)

From the practices in the USA some trends in DR development can be identified, as illustrated in Figure 4-17. The objective of deploying DR has been to go further than simply improving system reliability, and extend towards improving system efficiency and then system flexibility. The frequency with which DR is called upon has been extending from emergency use to daily use and further to real-time use. The participants in DR have been extending from large industrial and commercial customers to smaller commercial and residential customers, with more aggregators acting as intermediaries between utility or grid operators and individual customers. Finally, DR has been extending from one direction to both directions: from downwards, reducing load only, to both upwards and downwards, either increasing or reducing load as required.

### 1) DR for improving system reliability

The earliest and most commonly practiced DR focuses on system reliability. A customer, often a large industrial facility, agrees to reduce

load to guarantee system reliability under peak demand conditions or other emergency system events, and is paid an incentive for doing so. Since they are designed for emergency use, these DR programmes are infrequently called upon.

### 2) DR for improving system efficiency

More recently the focus of DR has been increasingly placed on system efficiency. Many DR programmes have begun to focus on non-crisis peak shaving – flattening load curves to improve the efficiency of long-term power system capacity use, since the generation, transmission and distribution capacity of a power system is sized to meet the expected peak demand.

### 3) DR for improving system flexibility

This emerging application of DR is very important for supporting RE integration, as mentioned in 4.6.1. For this purpose, automated and fast-acting dispatchable programmes are more effective and reactive programmes, particularly

price-mediated retail programmes, may be less effective. Changes to market rules and reliability standards are also required in some regions, to allow DR to participate in providing balancing services [mit11]. This application of DR is further envisioned in [ded10] as *demand dispatch*, which is expected to perform many of the same ancillary services currently provided by conventional power plants. Potential loads that are suitable for demand dispatch are those that, when remotely controlled, would go largely unnoticed by the customers, such as electric hot water heaters, heating-ventilation-air conditioning systems and electric vehicles.

#### 4.6.3 Technologies supporting more demand response

Although the success of DR programmes depends to a very large extent on effective commercial arrangements (including rate structures and pricing schemes) and on an accurate evaluation of cost-effectiveness, some new technologies are physically essential for DR to function or to function better. We discuss these briefly here.

##### 1) Advanced metering infrastructure technology

Advanced metering infrastructure (AMI) technology, commonly known as “smart metering”, permits fine-grained communication of system conditions to customers and fine-grained measurement of customer responses via two-way communications between the customer and the utility. It is the technical foundation for engaging more DR, especially from smaller customers in the future. It allows customers to receive information signals from utilities involving price, environmental impact

and other aspects, and utilities to receive time-of-use data that reveals how much energy customers use at any given time [mit11].

##### 2) “Behind-the-meter” technologies

AMI and home area networks also enable the use of a host of consumer-side technologies for building or home energy management, such as controllable appliances, monitoring and analysis of energy use, and price-responsive thermostats. These technologies can enable smaller commercial and residential customers to respond more actively to price or other supply-side signals. However, currently they are relatively immature and costly [mit11].

##### 3) Electric vehicles

Plug-in electric vehicles (EVs) are being promoted in a variety of useful roles. Not only are EVs low-emission, but they also have the potential to function as storage facilities from which energy can be dispatched to the grid or the home; they can be a dispatchable, night-time load to soak up excess wind energy; and they can provide balancing energy and ancillary services for RE integration.

##### 4) Cyber-security solutions

Since DR involves the coordinated reaction or control of a large number of loads using very many communications messages, there are serious concerns with the cyber-security risk. First, private customer information such as that concerning living habits might be vulnerable; this concern has led to public opposition to AMI and DR in some places. Secondly, information can be intentionally modified or faked to gain a financial advantage by fraud. Even more seriously from the system operation point of view, there are concerns that DR could be

manipulated so as to damage power system stability and security of supply, for example a large amount of load maliciously driven up or down. Therefore the success of DR depends on managing these risks through development of technologies, standards, policies and laws. The cyber-security solution must be an integral part of any DR programme from the beginning.

## 4.7 Summary

- 1) In order to address the increased variability and uncertainty brought about by integrating higher levels of large-capacity RE, the power system must become more flexible so as to maintain a constant balance between generation and load.
- 2) Power system flexibility can be achieved from the generation side (both RE generation and conventional generation), from the load side, and through EES acting as either generation or load. It can be better exploited if system operating technologies and practices are improved, and based on control shared over wider geographic areas with the support of transmission expansion.
- 3) RE generation can be made more predictable, controllable and dispatchable, or in other words more grid-friendly, by improving the design, operation and modelling technology at the generating unit, plant and plant cluster level.
- 4) Flexibility in conventional generation is the major source of power system flexibility currently and for the foreseeable future. Future generation planning should consider both capacity and flexibility. Different kinds of power plants have different degrees of flexibility, but it is difficult to quantify their flexibility and that of the overall system.
- 5) Higher-voltage-level transmission and the power-electronics-based FACTS and DC transmission technologies are paving the way for the transmission expansion needed everywhere for accommodating more large-capacity RE generation. The development of probabilistic transmission planning methods is also desirable for the more uncertain future.
- 6) Improvements in operational technologies and practices should be made at each stage in power system operation, namely in scheduling, dispatch and control. Of these, the development of more accurate RE generation forecasting and its incorporation into the scheduling and dispatch tools is the most important.
- 7) Demand response, supported by new smart grid, smart building and smart home technologies, is a promising source of power system flexibility in the future, but is still in its infancy. The rate at which it will mature and be widely applied depends heavily on an understanding of customer behaviour underlying the load demand, as well as on institutional and commercial innovations.
- 8) The integration of large-capacity RE and the application of demand response and other smart grid technologies will bring more challenges in cyber-security. Harmonization of cyber-security solutions is required both vertically within the power sector and horizontally across sectors such as power, communications and weather forecast systems.





# SECTION 5

## **Application of large-capacity EES to support RE integration**

## 5.1 General

This section examines the many uses of large-capacity energy storage to meet grid needs in the integration of large-capacity RE. Section 4 identified the need for greater flexibility in power systems as RE penetrations rise, and divided sources of flexibility into *grid-friendly RE generation, generation flexibility, demand response, system operation, and transmission expansion*. Here we revisit the first three concepts with an emphasis on energy storage as a means of providing generation flexibility for the grid, RE generation flexibility, and flexibility through demand response via electric vehicles.

Energy storage, due to its tremendous range of uses and configurations, may assist RE integration in any number of ways. These uses include, *inter alia*, matching generation to loads through time-shifting; balancing the grid through ancillary services, load-following, and load-leveling; managing uncertainty in RE generation

through reserves; and smoothing output from individual RE plants. We do not examine energy storage technologies themselves in great detail here, as the MSB EES Report [msb11] has already done so. Nor do we cover applications of energy storage for purposes not directly related to RE integration. Please refer to the MSB EES Report for a detailed and thorough discussion of all relevant energy storage technologies and their entire scope of use.

## 5.2 Promising large-capacity EES technologies

The universe of energy storage applications maps closely to the challenges of integrating RE into the grid. In the same way that RE integration creates needs at a variety of temporal scales, different types of energy storage are suited to different discharge times, from seconds to seasons. The tremendous application range of storage is shown in Figure 5-1.

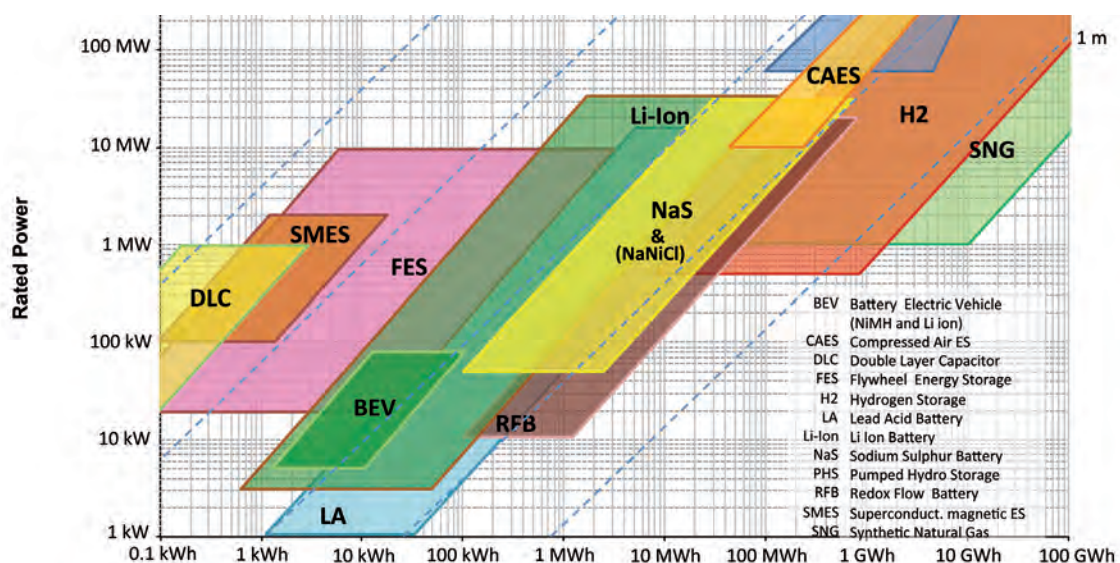

Figure 5-1 – Comparison of rated power, energy content and discharge time of different EES technologies [msb11]

The suitability of an energy storage resource for a particular discharge time-frame is determined by its *power density* and *energy density*. Power density refers to the energy storage technology's ability to provide instantaneous power. A higher power density indicates that the technology can discharge large amounts of power on demand. Energy density refers to the ability of the technology to provide continuous energy over a period of time. A high energy density indicates that the technology can discharge energy for long periods. Generally, energy storage technologies with the highest power densities tend to have the lower energy densities; they can discharge enormous amounts of power, but only for a short time. Likewise, technologies with the highest energy densities tend to have lower power densities; they can discharge energy for a long time, but cannot provide massive amounts of power immediately. This quality gives rise to a division of energy storage technologies into categories based on discharge times. While the categories are general and nearly always admit of exceptions, they are useful in conceptualizing how many roles storage can play with respect to renewables integration.

**Short discharge time** resources discharge for seconds or minutes, and have an energy-to-power ratio (kWh/kW) of less than 1. Examples include double layer capacitors (DLCs), superconducting magnetic energy storage (SMES), and flywheels (FES). These resources can provide instantaneous frequency regulation services to the grid that mitigate the impact of RE's uncontrollable variability.

**Medium discharge time** resources discharge for minutes to hours, and have an energy-to-power ratio of between 1 and 10. This category is dominated by batteries, namely lead acid (LA),

lithium ion (Li-ion), and sodium sulphur (NaS), though flywheels may also be used. Medium discharge time resources are useful for power quality and reliability, power balancing and load-following, reserves, consumer-side time-shifting, and generation-side output smoothing. Moreover, specific batteries may be designed so as to optimize for power density or energy density. As such, they are relevant to both the uncontrollable variability and partial unpredictability that RE generation brings to the grid.

**Medium-to-long discharge time** resources discharge for hours to days, and have energy-to-power ratios of between 5 and 30. They include pumped hydro storage (PHS), compressed air energy storage (CAES), and redox flow batteries (RFBs). RFBs are particularly flexible in their design, as designers may independently scale the battery's power density and energy density by adjusting the size of the cell stacks or the volume of electrolytes, respectively. Technologies in this category are useful primarily for load-following and time-shifting, and can assist RE integration by hedging against weather uncertainties and solving diurnal mismatch of wind generation and peak loads.

**Long discharge time** resources may discharge for days to months, and have energy-to-power ratios of over 10. They include hydrogen and synthetic natural gas (SNG). Technologies in this category are thought to be useful for seasonal time-shifting, and due to their expense and inefficiency will likely see deployment only when RE penetrations are very large. For example, large amounts of solar power on the grid will produce large amounts of energy in the summer months, but significantly less in the winter. Storing excess generation in the summer as hydrogen or SNG and converting

it back to electricity in the winter would allow a time-shift of generation from one season to the next. Such technologies can assist RE integration in the long term by deferring the need for transmission expansion and interconnection that arises due to the locational dependency of renewable resources.

### 5.3 Roles of EES in RE integration

#### 5.3.1 Grid-side roles of EES

The widest range of uses for EES lies in services to the grid operator in providing generation flexibility. These services also represent – from the grid operator’s perspective – the optimal use of storage as a tool to mitigate variability and uncertainty for an entire grid, rather than for specific loads or generation assets. The optimality arises from the fact that integration of large amounts of wind and solar energy over large geographic areas results in lower net variability and output uncertainty than the integration of a single RE plant, and so the need for services overall is reduced.

Nevertheless, it is simplistic to expect that this will be the only use of energy storage for RE integration that emerges in future grids. Indeed, the grid operator’s is not the only perspective that is important or relevant. Individual RE generators or plants facing specific incentive policies or isolated grids may find it in their best interests to co-locate generation and storage to level output prior to grid integration. On the demand side, expanded use of electric vehicles may provide substantial aggregate energy storage to the grid even if the storage resource itself appears sub-optimal to the grid operator. We avoid making any specific judgments or

predictions about exactly what the distribution of uses will or ought to be for EES in assisting RE integration, and instead simply present all of the potential uses from a variety of perspectives. The actual use of EES in various countries in the future will vary significantly depending on government policies, utility strategies, social and cultural factors, and the peculiarities of each particular grid.

Table 5-1 describes various grid-side roles of energy storage and their relevance to large-capacity RE integration challenges, along with some examples of EES technologies currently in use. These examples are impressionistic: the suitability of an EES technology for a particular use is highly context-dependent and will vary according to the needs of the grid operator and the specific design of the EES.

#### **1) Grid-side EES case study: The national wind power, solar power, energy storage and transmission demonstration project, Zhangbei, China**

The national wind power, solar power, energy storage and transmission demonstration project is co-sponsored by the Ministry of Finance, the Ministry of Science and Technology, the National Energy Bureau and SGCC. The project is located in North Zhangjiakou. The wind and solar resources are rich, but the local load is small and the installation is far away from the Beijing-Tianjin-Tangshan load centre. Thus the energy must be transmitted to the load centre by a high-voltage and long-distance transmission network. This project exemplifies the basic characteristics of RE development in China, and is a typical project for studying the problem of accommodating large-scale renewable power.

Table 5-1 – Grid-side roles of EES

[msb11] [tre10]

Role	Time scale(s)	Description	Benefits to RE integration	Examples of EES technologies
Time shifting / Arbitrage / Load levelling	Hours to days	EES allows storage of off-peak energy and release during high-demand period	A solution to diurnal generation cycles that do not match load cycles	NaS batteries, CAES, PHS, RFB
Seasonal shifting	Months	EES stores energy for months at a time, releasing it at times of the year when RE output is typically lower	Allows use of renewably-generated energy year-round, reducing reliance on traditional generation in seasons with, e.g., low sunlight	Hydrogen, SNG
Load following / Ramping	Minutes to hours	EES follows hourly changes in demand throughout the day	May mitigate partial unpredictability in RE output during critical load times	Batteries, flywheels, PHS, CAES, RFB
Power quality and stability	< 1 second	Provision of reactive power to the grid to handle voltage spikes, sags and harmonics	Mitigates voltage instability and harmonics caused or exacerbated by uncontrollable variability of RE generation	LA batteries, NaS batteries, flywheels, RFB
Operating reserves				
Frequency regulation	Seconds to minutes	A fast-response increase or decrease in energy output to stabilize frequency	Mitigates uncontrollable moment-to-moment variability in RE generation output	Li-ion batteries, NaS batteries, flywheels, PHS (with advanced variable speed control)
Spinning Reserves	~10 Minutes	A fast-response increase or decrease in energy output to cover a contingency, e.g. generator failure	Mitigates partial unpredictability of RE generation output, providing (or removing) energy when the RE resource does not perform as expected	PHS, flywheels, batteries
Supplemental reserves	Minutes to hours	A slower response resource that comes online to replace a spinning reserve	Provides firm power in the event of an especially severe and long-lasting drop in RE output. Use for RE integration is expected to be infrequent and low-value	PHS
Efficient use of transmission network	Minutes to hours	EES can help grid operators defer transmission system upgrades through time-shifting and more efficient operating reserves	Reduced transmission costs, mitigates locational dependency challenges of RE generation	Li-ion
Isolated grid support	Seconds to hours	EES can assist in the integration of RE on small power grids, such as those in use on islands	Time-shifting and power-quality applications to mitigate variability and unpredictability of RE generation	LA batteries
Emergency power supply / Black start	Minutes to hours	EES may be used to re-start the power system in the event of a catastrophic failure	No specific benefit accrues to RE integration, but storage resources may nonetheless provide black start capability to the grid	LA batteries

The planned capacity of the project is 500 MW wind power, 100 MW PV power and 110 MW energy storage. Phase I of the project, which was completed in 2011, consists of 100 MW wind power, 40 MW PV power and 20 MW energy storage. In order to test the performance of different types of battery storage, three types of battery storage are used in the 20 MW energy storage station: 14 MW of lithium iron phosphate ( $\text{LiFePO}_4$ , LFP) batteries, 4 MW of NaS batteries and 2 MW of vanadium redox flow batteries (VRFBs).

The architecture of the phase I project is shown in Figure 5-2. Through a panoramic intelligent optimal control system, panoramic monitoring, intelligent optimization, comprehensive control and smooth mode-switching between wind, solar and storage, the project has met targets of output smoothing, schedule following, load levelling and frequency regulation. The storage

system has contributed to making the wind farm and PV station more grid-friendly.

## 2) Grid-side EES case study: Battery storage in Southern China

A demonstration lithium iron phosphate battery storage station has been built in Shenzhen for both commercial and research purposes. The storage station was planned to have a capacity of 10 MW/40 MWh, divided equally into two phases. 4 MW/16 MWh of the phase I project has already been put into operation, and of the rest 1 MW/4 MWh will be installed in 2012. It is managed by the Peak/Frequency Regulation and Generation Company, a subordinate company of the China Southern Power Grid (CSPG) which is responsible for the construction, operation, maintenance and management of the peak/frequency regulating power plants in CSPG, including several hydro power plants and all pumped-hydro storage power plants.

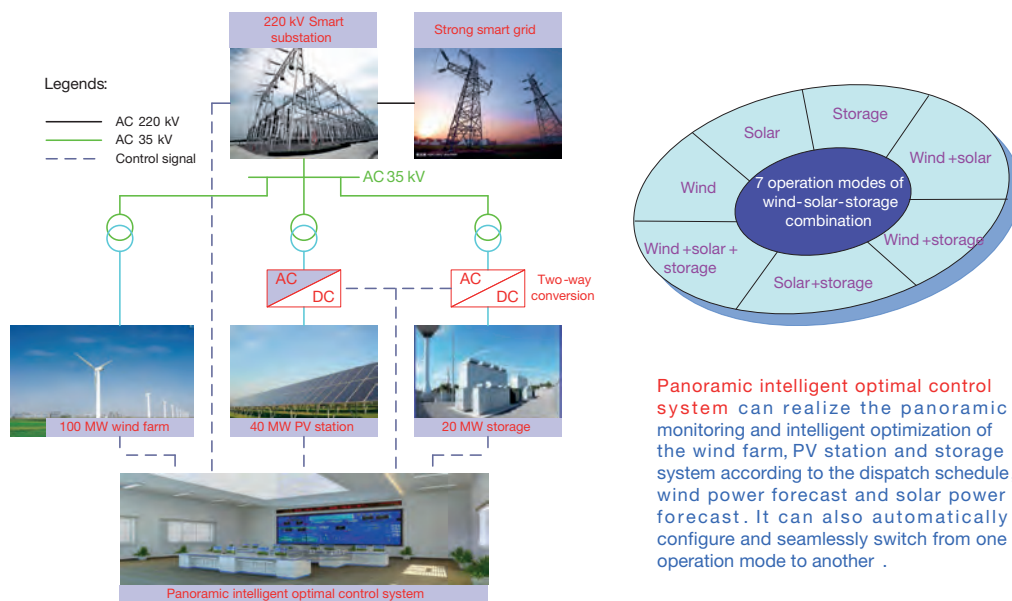

Figure 5-2 – Architecture of the national wind power, solar power, energy storage and transmission demonstration project, Phase I

(SGCC)



Battery units are connected at the 10 kV bus of the 110 kV Biling substation via 10/0.4 kV transformers, as shown in Figure 5-3. A battery unit consists of battery, power conversion system (PCS) and battery management system (BMS). The storage station can work in several modes. It can adjust its output according to a

scheduled curve given by the dispatch centre or a fixed curve for load levelling, or participate in advanced regulation and backup services. For example, the load forecast curve at the Biling substation of one day with and without load shifting by the storage station is shown in Figure 5-4.

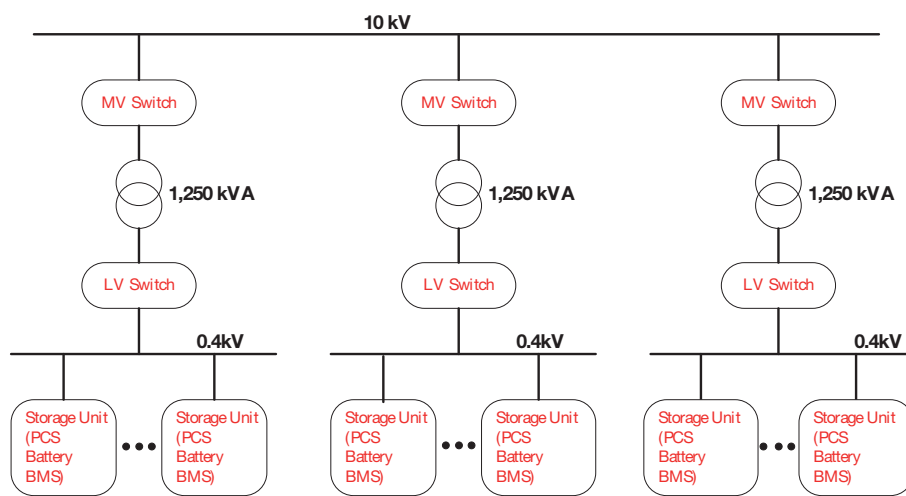

Figure 5-3 – Architecture of the Biling energy storage station (BYD)

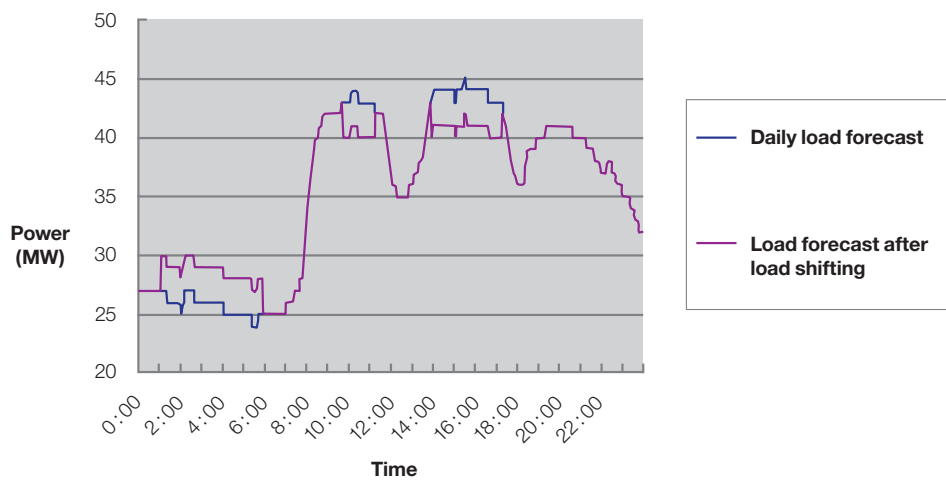

Figure 5-4 – A daily load forecast curve at the Biling substation with/without storage (BYD)



### 3) Grid-side EES case study: Multi-application use of pumped hydro storage in Taiwan

Though PHS is historically associated with time-shifting, newer units offer a considerably expanded range of operation, including the use of PHS for operating reserves such as frequency regulation and spinning reserves. The Taiwan Power System, for example, contains ten PHS units: four 250 MW units located at the Ming-Hu hydro plant and six 267 MW units located at the Ming-Tan hydro plant.

Because Taiwan's grid is isolated, it must guarantee sufficient operating reserves to maintain system frequency without load-shedding in the event of the failure of its largest generating unit. In Taiwan's case, this largest unit is 950 MW, a substantial portion of Taiwan's 34 630 MW of capacity. Taiwan thus uses PHS units in daily operations for both time-shifting and operating reserve functions simultaneously. During peak demand periods, the PHS units are operated in generating mode, supplying both frequency regulation through



Figure 5-5 – A PHS plant in Taiwan  
[tem12]

automatic generation control of the turbine speed and a reduction in system operating costs by replacing peaking generators. During off-peak periods, PHS units operate in pumping mode to consume surplus energy, and also offer emergency reserves by way of PHS load-shedding. That is, if a large generator fails in an off-peak period, the PHS's load from pumping may be immediately shed to stabilize system frequency [rvp08].

#### 5.3.2 Generation-side roles of EES

Operators of RE generation plants may use energy storage technologies to assist in the integration of a particular plant, or of several plants that feed into the same substation. Using the terminology of section 4, EES used in this fashion serves to improve the grid-friendliness of RE generation itself. It is important to understand that generation-side use of energy storage is not simply a shift in ownership of the storage resource, but an entirely different role for storage from that envisioned by grid-side use of EES. Rather than using EES as a tool to balance an entire power grid, an RE generation plant may use EES to provide integration applications prior to grid integration, either at the plant or substation level. While the technical requirements of generation-side EES applications are similar to those of grid-side EES, greater flexibility is required of generation side EES facilities, because a single RE plant exhibits greater variability and uncertainty than many RE plants aggregated on the same grid. This means that dedicating EES facilities to specific RE generation results in proportionately higher costs than using EES to balance net variability and uncertainty on the grid. For isolated and geographically-constrained grids,

however, co-location of RE generation and EES may be an attractive option, as balancing such grids through interregional trading, conventional backup capacity or demand-side management is more challenging than for larger and more interconnected grids.

Essentially, generation-side use of EES aims to transform an uncontrollably variable and partially unpredictable resource into a controlled and predictable one – it turns RE generation into something that looks very much like conventional energy generation. Such an RE generation resource is said to be *dispatchable*. It may also play a role in effectively utilizing limited transmission capacity, particularly where the RE generation is located on an isolated or weak grid. Generation-side uses of EES include:

- **Time shifting.** The dedicated energy storage facility stores energy whenever

its generator produces it, and stands ready to dispatch energy to the grid when needed. This can make RE output both predictable to grid operators and co-temporal to demand. Time shifting functions require EES facilities to store large quantities of energy for significant periods of time, from hours to days. NaS batteries exemplify the qualities needed for this function: they may store relatively large amounts of energy efficiently for hours at a time as well as ramp quickly, as shown in Figure 5-6. Storage efficiency is very important for economical operation of time shifting, as an inefficient storage facility will lose significant portions of the energy it time-shifts. Efficiency varies greatly by EES technology and also by the operation profile, as is covered in detail in the MSB EES Report.

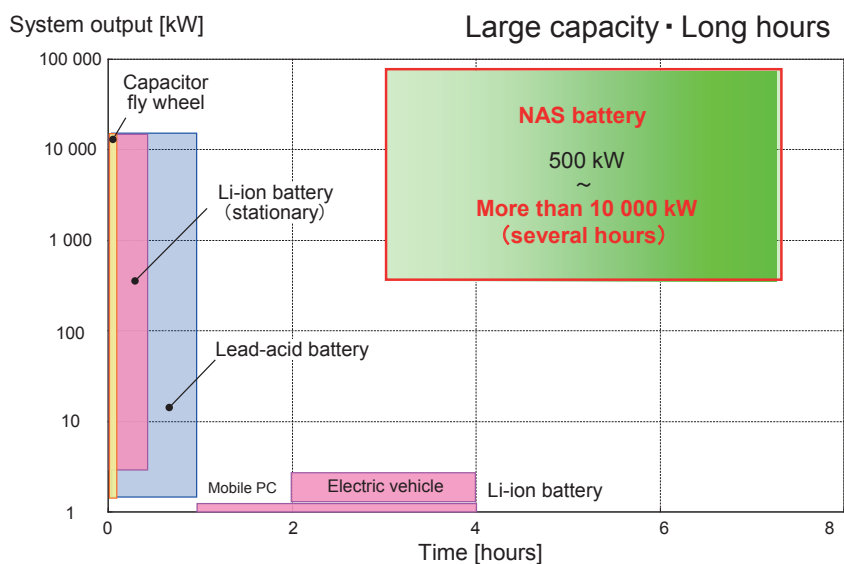

Figure 5-6 – Comparison of battery output and duration (NGK)

- Output smoothing/flattening.** Even when RE generation is producing energy at a time when it is needed, the EES resource may be used to smooth out fluctuations in frequency and voltage that result from the inherently variable nature of RE generation. Smoothing functions require ramping capability – the ability to rapidly change power output or uptake in order to regulate the output of the RE plant. When RE output spikes, the EES technology must be capable of storing the excess energy quickly. Conversely, when output suddenly drops, the storage system must be able to release energy quickly to provide extra power, keeping the plant output stable. The necessary function of storage facilities varies according to the requirements. In some cases just smoothing output is satisfactory, but in other cases output is required to be kept at the fixed values. Output smoothing at the plant level reduces the need for power quality and ancillary services on the grid itself.
- Transmission utilization efficiency.** Because RE generation is location-

dependent, sufficient transmission may not be available to move energy to loads. It is often the case that transmission may be available, but it may be heavily congested. Generation-side EES resources may allow for more efficient use of transmission capacity by allowing an RE generation facility to wait to use the transmission line until congestion has cleared.

### 1) Case study of EES support of RE plant integration in Japan

In 2008, Japan Wind Development Co. (JWD) began operating the first commercial “Wind and NAS Battery Hybrid System” (see Figures 5-7 and 5-8). This plant consists of 51 MW (1 500 kW × 34 units) of wind turbines and 34 MW (2 000 kW × 17 units) of NAS batteries. The NAS battery application regulates the output of the plant to produce more electricity during high demand (price) periods, and less during low demand (price) periods. Output can also be reduced when system conditions require. JWD has operated its wind and EES technologies in combination according to plan for 3 years.



Figure 5-7 – JWD’s wind and NAS battery hybrid system in Japan  
(NGK)

## Compensation for intermittent renewable energy

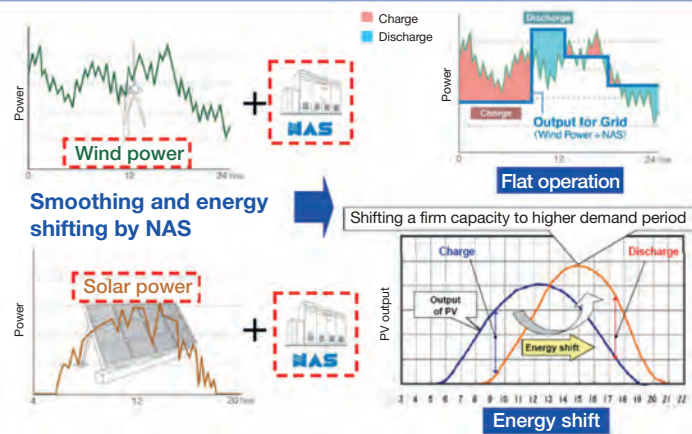

Figure 5-8 – Compensation for intermittent RE  
(NGK)

### 5.3.3 Demand-side roles of EES

Energy storage has a number of applications for energy consumers; time-shifting to reduce consumption of grid electricity at peak times, firm power for off-grid, renewably-powered homes or critical industrial applications, and emergency power supply are a few examples. These applications, however, are related more to the needs of the consumer than to solving particular challenges related to the integration of large-capacity RE. In seeking demand-side EES technologies that directly relate to large-capacity RE integration, only one critical type emerges: electric vehicles.

EVs are significant to RE integration because of the potential for *aggregation*. While a single EV can store a relatively small amount of energy, many EVs all plugged into the grid at the same time may someday be operated as a single large energy-storage device, or *virtual power plant* (VPP). As such an electric vehicle virtual power plant (EVPP) may provide both time-shifting and other energy applications to

store RE at times of low demand and release it to meet peak demand, as well as operating reserves such as frequency regulation service, increasing quantities of which are needed as more variable RE generation is added to a system [mev09]. Such functions are referred to as vehicle-to-grid (V2G) systems.

EVPPs providing V2G services must satisfy the requirements of both vehicle owners and grid operators. By aggregating individual vehicles into a single controllable EES resource, an EVPP can potentially achieve this balancing act, bidding and providing ancillary services at all times without locking a vehicle owner into a charging station from which she or he cannot depart at will. Thus the vehicle owner is not inconvenienced and the grid operator may treat the EVPP as though it were a conventional provider of ancillary services [tec10]. Aggregation also allows for the creation of a large enough virtual facility to meet the capacity requirements of many ancillary service markets, which are often too high for an individual EV to satisfy.

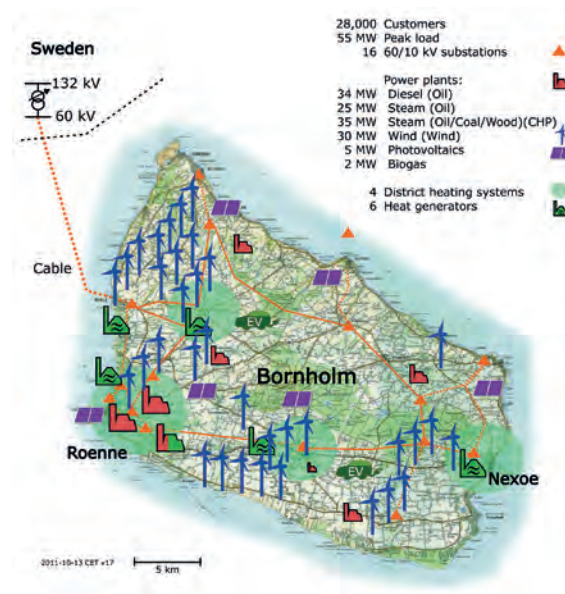

Figure 5-9 – Bornholm’s distribution grid and power plant locations  
[evf10]

EVPPs are still conceptual in nature, and involve significant complexities that are beyond the scope of this report. A number of modelling efforts are presently examining EVPP feasibility and architecture. One of the more robust and RE-integration relevant modelling efforts is located on the Danish island of Bornholm, which relies heavily on wind turbines with 30 MW of wind capacity that services 22 % of the island’s load. The EDISON project on Bornholm aims to coordinate charging and discharging of EVs so as to optimize utilization of wind energy on the island’s grid. Successfully implementing V2G functionality so as to support grid integration of RE will require a host of new standards and grid codes [evf10] [gcr09].

#### 5.4 Technology needs of large-capacity EES applications

The interconnection and facility management needs of EES technologies are discussed at length in the MSB EES Report, and these needs

do not change considerably when EES is used to support RE integration. Consequently, we do not cover those issues again here. Rather, this section focuses on a larger-scale inquiry as to the role of EES in assisting RE integration on a specific electricity grid. That is, how can a prospective operator of an EES facility – be it grid-side, generation-side, or demand-side VPP – determine whether and how to design, place and utilize the facility? What type of storage to install, and with what capacity, depends on how that storage will be used. How it is used depends on where it is located and the specifics of the power system that it serves. Where it is located depends on both what type of storage is being installed and on the siting of other future generation.

EES technologies tend to be flexible; they can provide multiple services within a number of time scales, as explained above. A PHS plant with a variable-speed turbine, for example, may participate in both time-shifting functions and frequency regulation. Its design specifications



are likely to change depending on the proportion of operations that fall under time-shifting and the proportion of operations that fall under regulation. Those proportions, in turn, depend on the generation profiles and interconnection status of electricity grids, which will change substantially over the coming decades.

Because an EES technology can draw on a number of value streams which themselves may be met by other means, there is a need for *optimization* of storage placement and use within the context of the power system as a whole, both today and into the future. Research on storage optimization is already under way, but there is relatively little convergence or organization of results at the moment. In 2009 alone, over 500 published articles applied optimization algorithms to RE in some way, but a review of the literature demonstrates the experimental and highly varied topics and approaches of the researchers [oma11]. An “optimal” optimization strategy that is ready for global, commercial-scale use has yet to emerge for low-carbon energy system planning.

In addition to their present lack of convergence, an impressionistic review of several popular storage-specific optimization studies reveals a focus on optimizing economic dispatch decisions for a specific type of storage facility on a known grid configuration, often a simplified or isolated grid [ede10] [mlt10] [ops08] [sco12] [yce03]. These studies treat the installation of an EES facility as an *a priori* decision. In other words, they assume a storage facility, and then go about determining its optimal operation. This is not to say that such optimization studies are not necessary and useful – they are most certainly both, particularly to grid operators working with existing or planned EES facilities.

But there is a need for peer-reviewed, consensus-supported optimization tools at a higher level of abstraction. Such tools could provide commercial-level decision support for the planning of storage on the grid at a pre-installation stage from a more global perspective, and across larger time scales. Indeed, when considering the long-term needs of global electricity grids as they accommodate ever-increasing penetrations of variable RE, the decision of when and where to place certain kinds of energy storage in the first place is a primary question. The HOMER optimization model for distributed power, which allows a user to evaluate economic and technical feasibility for a wide range of remote, stand-alone and distributed generation applications, represents a potential starting point for developing such tools [hey12].

Based on the topics discussed throughout this paper, an EES planning and decision tool for utilities and facility developers might consider the following factors, both at present and in future scenarios:

- amounts and net variability of RE generation on the grid;
- interconnectivity of the grid to other grids, and balancing capabilities between them;
- conventional backup capacity available and desirable;
- demand-side management applications and capabilities;
- system costs or market prices for operating reserves, power quality services, and balancing energy;
- time-shifting/arbitrage potential in relevant energy markets; and
- technological capabilities and flexibility of various EES technologies.

Such an analysis would provide a clearer picture of the need for EES on a particular grid as compared to other solutions to RE integration, as well as a sense of its likely future uses. This knowledge in turn may inform utility or facility-owner decisions about where to place EES, in what amounts, and how to use the technology.

### 5.5 Summary

EES may serve as a source of flexibility for the integration of RE in a wide variety of ways, from improving the grid-friendliness of RE generation itself through increasing generation flexibility to providing demand response from electric vehicles. These represent the near-term uses of energy storage as one means among many of providing system flexibility. In the medium term, energy storage may allow, through both

balancing and time-shifting functions, for more effective and full utilization of transmission lines and thus assist in transmission expansion and siting to RE resource areas. In the longer term, energy storage may influence energy system planning in unique and profound ways. Large-scale, long-term energy storage such as hydrogen and synthetic natural gas may provide a means of storing seasonally-produced RE for months or years and thus serve the need for dispatchable and controllable generation that is currently met through fossil fuels. The cost of such storage is currently considered prohibitively expensive and the energy penalties too high by many system operators and governments. Advances in technology and shifts in the politics of energy may be necessary before such a future becomes likely.



# SECTION 6

## **Standards for large-capacity RE integration**

## 6.1 General

Besides improvements in the technologies, methods and operational practices described in sections 4 and 5, improvement in standards is another important aspect of supporting the integration of more large-capacity RE generation while maintaining power system reliability and stability. Many device-level standards have already been developed, such as the IEC 61400 series on wind turbines developed by IEC TC 88 and the IEC 60904 series on PV devices developed by IEC TC 82. These standards are very important for promoting the development of wind and solar PV power generation technologies. A new TC, IEC TC 117, was also established in 2011 for solar thermal power plants.

But for grid integration, more relevant are the system-level integration standards prescribing the performance of RE power plants and their interaction with the power system, such as the requirements for the interconnection, design, modelling, testing, monitoring, control and operation of RE power plants. Since solar thermal power plants use steam-turbine-driven synchronous generators and standards for

them can therefore easily be adapted from those for conventional thermal power plants, this section focuses on integration standards for large-capacity wind and PV power plants.

## 6.2 Present situation

Currently, RE integration standards mainly exist at the national level or grid company level. Based on experiences and lessons learned from the past and from other countries [pei12], many countries or grid companies have been updating their general grid codes, or developing separate standards documents such as requirements or guidelines, to meet the demands of fast-growing wind and PV power generation. Some standards for wind power plant interconnection in some major countries are listed in Table 6-1. Some of the grid codes also include requirements for PV power integration, since they are intended to address the interconnection of all kinds of generation as well as loads (i.e. all customers of the grid). The major integration standards for wind and PV power in China are listed in Table 6-2, including national, industry-wide and grid company level standards.

Table 6-1 – Some wind power plant interconnection standards in some major countries

Country	Issued by/in	Numbering or version	Title
Brazil	ONS/2008		Brazilian Grid Codes ( Procedimentos de Rede )
	EPE/2009		Guidelines for wind power generation expansion in Brazil
Canada	Manitoba Hydro/2009	Version 2	Transmission system interconnection requirements
	Hydro-Québec/2009		Transmission provider requirements for the connection of power plants to the Hydro-Québec transmission system
	BCTC/2008	Revision 0	60 kV to 500 kV technical interconnection requirements for power generators
	CanWEA/2006		CanWEA base code
	AESO Alberta/2004	Revision 0	Wind power facility technical requirements
Denmark	Elkraft System and Eltra/2004	Regulation TF 3.2.5	Technical regulation for the properties and the regulation of wind turbines connected to grids with voltages above 100 kV
Germany	E.ON Netz/2006		Grid code high and extra high voltage
Ireland	EirGrid / 2009	Version 3.4	EirGrid grid code
Japan	Ministry of Economy, Trade and Industry/2004		Guidelines of technical requirements for system interconnection for maintaining power quality
	Japan Electric Association/2010		Grid interconnection code
	Ministry of Economy, Trade and Industry/2009		Ministerial ordinance setting technical standards concerning wind power generation facilities
	Japan Electric Association/2001		Wind turbine generator code
Spain	REE/2006	P. O. 12.3	Installations connected to a power transmission system and generating equipment: minimum design requirements, equipment, operations, commissioning and safety
UK	National Grid Electricity Transmission plc/2010	Issue 4 Revision 5	The grid code
USA	FERC/2005	RM05-4-001; Order No. 661-A	Interconnection for wind energy

Table 6-2 – Major integration standards for wind and PV power in China

Issued by	Numbering	Title	Notes
AQSIQ	GB/T 19963-2011	Technical rules for connecting wind farm to power system	National standard, replacing GB/Z 19963-2005
NEA	NB/T 31003-2011	Design regulations for large-scale wind power connecting to the system	Industry-wide standard
NDRC	DL/T 5383-2007	Technical specification for wind power plant design	Industry-wide standard
SGCC	Q/GDW 392-2009	Technical rules for connecting wind farm into power grid	Grid company standard
SGCC	Q/GDW 432-2010	Specification for wind power dispatch and operation management	Grid company standard
SGCC	Q/GDW 588-2011	Functional specification for wind power forecasting	Grid company standard
SGCC	Q/GDW xxx-201x	Technical rules for wind farm reactive power configuration and voltage control	Grid company standard, in process of approval
SGCC	Q/GDW xxx-201x	Standard for wind farm dispatch and operation information exchange	Grid company standard, in process of approval
SGCC	Q/GDW xxx-201x	Procedure for wind turbine grid compatibility testing	Grid company standard, in process of approval
AQSIQ, SAC	GB/Z 19964-2005	Technical rules for connecting PV power station to power system	National standard, under revision
SGCC	Q/GDW 480-2010	Technical rules for PV power station connected to power grid	Grid company standard
SGCC	Q/GDW 618-2011	Test procedures for PV power station connected to power grid	Grid company standard
SGCC	Q/GDW xxx-201x	Technical specification for PV power station power forecast	Grid company standard, in process of approval

Since their intention is to solve similar problems, the contents of integration standards in different countries or grid companies are often similar. For example, most of the wind power plant interconnection standards contain requirements for the following aspects:

- (1) Voltage range for continuous operation
- (2) Frequency range for continuous operation
- (3) Active power set point and ramp rate control

(4) Reactive power (power factor) control and voltage regulation

(5) LVRT

(6) Power quality, e.g. flicker, harmonics, voltage fluctuation.

However, owing to the differences among the countries and grid companies and how their grids are managed, as well as the different

features and development stages of RE power generation, these integration standards may also differ in much of their contents and especially in the specific values of certain requirements. For example, the newly updated GB/T 19963-2011 (replacing GB/Z 19963-2005) in China, which was issued at the end of 2011 and entered into force on 1 June 2012, also sets out requirements on the number of circuits connecting power plants to the grid, generation forecast and report, configuration of reactive power compensation, provision of simulation models and parameters, communication with the grid operator, and provision of field test reports. To take the low-voltage ride-through requirement as a specific example, Figure 6-1 shows the differences among major countries or grid companies. In addition to the LVRT requirement, some countries or grid companies (e.g. E.ON Netz in Germany) also require wind power plants to provide reactive power during a fault period to help system voltage recovery.

### 6.3 Future needs

In order to support the integration of more large-capacity RE generation, much standardization effort is needed. Since it would not be useful to discuss detailed technical requirements here, some important general considerations are given below.

- 1) Standards should be developed and kept continuously updated to reflect advances in RE generation technology and encourage RE to become more grid-friendly, with performance comparable or even superior to that of conventional generators. For example, the ability of wind power plants to provide zero-voltage ride-through is becoming an industry norm, high-voltage ride-through is under discussion, and inertial response may also be required in the near future [pei12] [sra12].

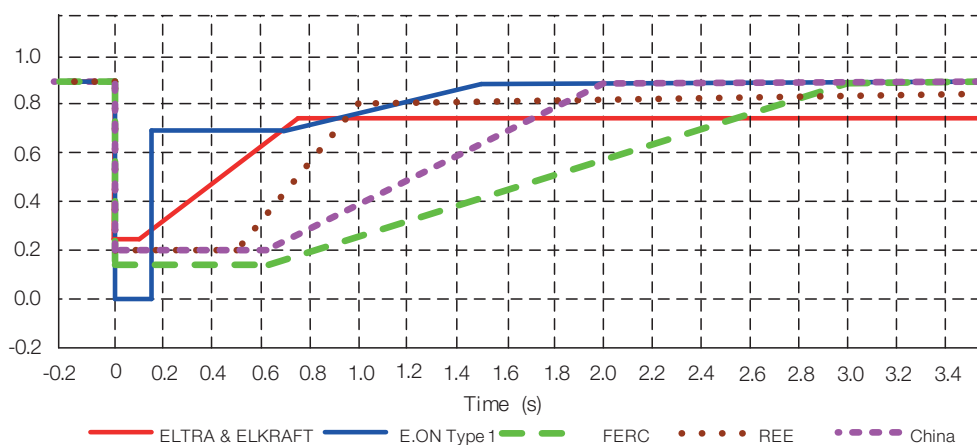

Figure 6-1 – Differences in LVRT requirements in major countries or grid companies (SGCC)

- 2) Interconnection standards should place performance requirements at the plant level or at the point of interconnection rather than interfere in how these requirements are met within the RE power plant. RE power plants should be treated as closely as possible in the same way as conventional power plants for equity and simplicity, while appreciating the unique features of RE power generation.
- 3) Interconnection standards should also consider anticipated as well as existing conditions, aggregate impacts, and the effects of displacing conventional generation by RE generation. It is difficult to modify requirements on existing facilities after the fact [opp11].
- 4) Besides interconnection standards, standards or best-practice documents are also needed in the whole planning, design, commissioning and operation process for RE integration, such as modelling, testing, communications, monitoring, control, generation forecast, scheduling and dispatch. For example, the Typical Design of Wind Farm Electrical Systems [tpd11] issued by SGCC in August 2011 has provided modular design guidance for wind power plants in China to meet the interconnection performance requirements in an efficient and cost-effective way. The IEEE PES Wind and Solar Plant Collector System Design Working Group is also planning to initiate standards-making activities on wind power plant collector system design [aba11]. In this work, the collector system of a wind power plant is informally defined as “everything in the power plant that is not a wind turbine generator”, which is similar to the concept of “electrical system” used by SGCC.
- 5) Early experience in distributed RE integration may be helpful for developing standards for large-capacity RE integration, but large-capacity RE integration differs in many respects from distributed RE integration and should be treated very differently. One example is that the current standards for relatively small-capacity PV power plants may not be applicable to large-capacity desert PV power plants. Another example is the conflict between the LVRT requirements of FERC Order NO. 661-A and IEEE Standard 1547 for distributed resources interconnection [bac11].
- 6) In addition to continuing the development of device-level standards, the IEC should make an effort to develop system-level, performance-oriented RE integration standards, based on relevant national, regional or grid company standards. Although the challenges and practices of RE integration differ substantially among different countries, there are many common issues and interests. To enable this to happen, platforms for worldwide research, discussion and exchange of experiences are needed. To facilitate communication, developing a common language and terminology for RE integration might be a good starting point.
- 7) Other, supporting standards are also needed in related technologies, such as MTDC and DC grids as well as demand response [des10], but they are only indirectly relevant. The IEC and other standardization bodies in some cases already have groups addressing them.

# SECTION 7

## **Conclusions and recommendations**



## 7.1 Conclusions

Renewable energies, driven by climate change, fuel security and other motives, will be providing more and more of our electricity in the future. They represent an opportunity and a risk. The opportunity is not the subject of the present paper; it is assumed simply that excellent reasons exist for the share of renewables in the energy mix to grow considerably, and that they will therefore do so. The risk stems from characteristics of certain renewables which make them difficult to incorporate into our current electricity system. It is only the renewables (and their large-scale use) presenting that risk which are dealt with here, for together with many others it is the IEC's responsibility to help the world community cope with the risk. The renewable energies in question are wind and solar – both photovoltaic and thermal – and the risk is that if they are present on a large scale their variability and unpredictability will prevent the correct functioning of the whole electricity supply grid.

We have seen that the more renewables we feed into the grid, the more difficult the grid and its electrical properties will be to control and to operate efficiently. The risks include frequency and voltage fluctuations and outages, as well as major inefficiencies and waste. Much is already known and done to stay in control, but it is not enough for the 15 %, 25 % or even 35 % of variable renewables some grids will contain over the next decades. Section 4 shows that “grid-friendly” renewable generation and “renewable-friendly” grids are both needed, and suggests some methods for achieving them. These include improved forecasting of the likely energy available, flexibility and reserves to guarantee supply and the grid's electrical characteristics, information and fast reactions to enable

constant control, and enhanced transmission capability to adjust the grid without wasting energy. A constant in many of the methods is that the availability of large-scale EES will make them easier to apply, so the lessons from the IEC's preceding White Paper on that subject have been very useful in the current one.

Two fundamental conclusions may be drawn. First, we understand, to a certain extent, what will be needed to cope with large-scale renewables in the grid – **but we do not yet have what we need**. Very considerable efforts will be needed to obtain it, whether it is knowledge, practical experience, tools, guidance or investment. Secondly, neither theoretical knowledge nor practical experience is enough if it is applied by just those who know, or just those who have the experience, separately in their own domains. That is happening today, and it will obviously not be able to cope with the increase in renewables. Instead, it will be required to attack the problem together, across borders and areas of responsibility, basing the solutions on common research, tools and infrastructure, and in particular on common rules and international standards. The problem is too complex for any other approach to work.

## 7.2 Recommendations addressed to policy-makers and regulators

In addition to the recommendations below, those already formulated in the two previous IEC White Papers remain relevant for the present case, in particular Recommendations 5.5.1, 5.5.4, 5.5.5, 5.6.2 and 5.7.2 from the MSB EES Report, and Recommendations 8.2.1, 8.2.3, 8.2.4 and 8.2.9 from the MSB EEE Report.

### **Recommendation 7.2.1 – Coordinating all actors**

Since integrating large-scale RE requires many actions – at different timescales, levels of control and points in the generation life cycle – and the tools and infrastructure must be provided by many actors both public and private, the IEC recommends governments and intergovernmental organizations to take responsibility for uniting all the relevant stakeholders in a single effort to set the rules, develop the standards and take the decisions needed.

### **Recommendation 7.2.2 – Single framework for connecting and controlling renewables**

The interdependence of the different parts of any grid with a high proportion of renewables, such as the renewable sources themselves, the control centres at various levels and central and distributed storage, requires one framework into which the connection rules, pricing and investment incentives and operational standards will all fit. The IEC recommends that such a framework, which will be simultaneously technical and policy-related and must leave the necessary room for different policies in different economies, be worked out internationally under governmental leadership.

### **Recommendation 7.2.3 – Regulations to enable integration**

The IEC recommends regulators to frame connection rules and incentives (in pricing and for investments) in harmony with the framework called for in Recommendation 7.2.2, so that solving every different aspect of the problems of integrating renewables may be encouraged rather than obstructed by regulations. In

particular regulators should encourage the implementation of larger balancing areas (fully-connected grids under central control), without neglecting local power quality, so as to enable the concerted operators to reduce average variability in generation. They should also set up stable and predictable financial incentives which make the best technical and public-policy solutions simultaneously the most attractive ones financially.

## **7.3 Recommendations addressed to utilities, industry and research**

### **Recommendation 7.3.1 – Enhanced transmission as a precondition for renewables**

The IEC recommends that transmission infrastructures should be developed appropriately and in time, in cooperation between utilities and renewable generation developers, well in advance of any steep rise in the proportion of renewables. In most cases the integration of renewables cannot take place without a corresponding enhancement. UHVAC and (U)HVDC techniques, where feasible, have an increasingly wide application.

### **Recommendation 7.3.2 – Stochastic forecasting**

The IEC recommends significant effort to be put into developing and operating with stochastic forecasting techniques in addition to deterministic algorithms, despite their novelty in the historical context. When combined with the ability to react fast to forecast errors, they promise better optimization of the entire park of generation resources.

**Recommendation 7.3.3 – Research for forecasting and complex modelling**

The IEC recommends industry, utilities and research institutions to develop the renewable integration scenarios sketched in the present paper, in particular for forecasting and for modelling grid behaviour with a view to control algorithms, and push research forward rapidly so that experience can be gained and the algorithms refined.

**Recommendation 7.3.4 – Research for cluster connection and control**

The IEC recommends industry and researchers to develop the electronics and the techniques for active power/frequency control, reactive power/voltage control and multilevel control for the whole of a large RE plant cluster (generation units, plants, substations and the cluster).

**Recommendation 7.3.5 – Research into EES**

The IEC recommends industry, research institutes and utilities to put significant effort into developing EES so as to support the integration of large RE systems into electric grids.

**Recommendation 7.3.6 – Forecasting the demand side**

The IEC recommends industry, research institutes and utilities to develop models and forecasting techniques for the demand side in order to develop more reliable dispatching programmes.

**7.4 Recommendations addressed to the IEC and its committees****Recommendation 7.4.1 – Technical contribution to the RE integration framework**

The MSB recommends the IEC to take an active part in the development of the framework called for in Recommendation 7.2.2, cooperating with governments and international bodies and taking responsibility for the technical portions.

**Recommendation 7.4.2 – Rapid progress in RE integration standards**

The MSB recommends the SMB to implement the list of future needs given in section 6.3 of the present paper, paying particular attention to the harmonization of already existing national or regional standards under the framework.

**Recommendation 7.4.3 – Synergy with industry associations on RE integration**

The MSB recommends the SMB to encourage TCs to follow developments at the global industry level. Many industry associations are active in this area and produce studies and position papers which contribute certain views of the problems. Standardization efforts should take account of these efforts.

# References

- [aba11]** Richard Piwko, et al.: *A Blast of Activity: Wind Power at the IEEE Power & Energy Society*, IEEE Power & Energy Magazine, 9(6), p26-35, Nov/Dec 2011.
- [adr11]** Federal Energy Regulatory Commission: *2010 Assessment of Demand Response and Advanced Metering*, p21, Staff Report, Feb 2011.
- [atp11]** Mark Ahlstrom, et al.: *Atmospheric Pressure: Weather, Wind Forecasting, and Energy Market Operations*, IEEE Power & Energy Magazine, 9(6), p97-107, Nov/Dec 2011.
- [bac11]** Mark G. Lauby, et al.: *Balancing Act: NERC's Integration of Variable Generation Task Force Plans for a Less Predictable Future*, IEEE Power & Energy Magazine, 9(6), p75-85, Nov/Dec 2011.
- [coc11]** Hannele Holttinen, et al.: *Currents of Change: European Experience and Perspectives with High Wind Penetration Levels*, IEEE Power & Energy Magazine, 9(6), p47-59, Nov/Dec 2011.
- [cvw11]** Task Force on the Capacity Value of Wind Power, IEEE Power and Energy Society, et al.: *Capacity Value of Wind Power*, IEEE Transactions on Power Systems, 26(2), p564-572, May 2011.
- [ded10]** Alec Brooks, et al.: *Demand Dispatch: Using Real-Time Control of Demand to Help Balance Generation and Load*, IEEE Power & Energy Magazine, 8(3), p20-29, May/June 2010.
- [des10]** Scott Coe, et al.: *Demanding Standards: Developing Uniformity in Wholesale Demand Response Communications to Enhance Industry Growth*, IEEE Power & Energy Magazine, 8(3), p55-59, May/June 2010.
- [dlr05]** German Aerospace Center, et al.: *Concentrating Solar Power for the Mediterranean Region*, Report, April 2005.
- [eck11]** V. Eckert: <http://af.reuters.com/article/commoditiesNews/idAFL6E7NT1WK20111229?pageNumber=2&virtualBrandChannel=0>, Article 2011, Accessed 29 March 2012.
- [ede10]** S. You, et al.: *Economic Dispatch of Electric Energy Storage with Multi-service Provision*, IPEC 2010.
- [eis11]** Douglas Todd: *Managing Large-Scale Penetration of Intermittent Renewables*, MITEL Symposium on Managing Large-Scale Penetration of Intermittent Renewables, Cambridge/ U.S.A, 20 April 2011.
- [epa10]** European Photovoltaic Association: *Global Market Outlook for Photovoltaics until 2014*, Report, May 2010.
- [ern11]** Ernst Scholtz: *Grid Integration of Renewables: Challenges and Technologies*, MITEL Symposium on Managing Large-Scale Penetration of Intermittent Renewables, Cambridge/ U.S.A, 20 April 2011.
- [esp10]** Gobierno de España: *Spain's National Renewable Energy Action Plan*, Report, 2010.
- [ete11]** Yi Zhang, et al.: *Overview of the Practice of Renewable Generation Integration and Transmission Planning in North America*, Energy Technology and Economics, 2011, 23(8), p1-7, 23, in Chinese.
- [evf10]** C. Binding, et al.: *Electric Vehicle Fleet Integration in the Danish EDISON Project – A Virtual Power Plant on the Island of Bornholm*, IBM Research Report RZ 3761 (2010) # 99771.

- [ewe05]** The European Wind Energy Association: *Large Scale Integration of Wind Energy in The European Power Supply: Analysis, Issues and Recommendations*, Report, Dec 2005.
- [ewe11]** The European Wind Energy Association: *Wind in Our Sails: The coming of Europe's Offshore Wind Energy Industry*, Report, 2011.
- [fat11]** Aidan Tuohy, et al. *Flexibility Assessment Tool: IEA Grid Integration of Variable Renewables Project*, IEEE Power & Energy Society General Meeting Power System Flexibility Panel, 2011.
- [gcr09]** EDISON Consortium: Report: WP2.7 Grid Codes and Regulation Related to EVs, Report, 2009.
- [ger10]** Federal Republic of Germany: *National Renewable Energy Action Plan in accordance with Directive 2009/28/EC on the promotion of the use of energy from renewable sources*, Report, 2010.
- [gre12]** Webpage: [http://www.greenrhinoenergy.com/solar/technologies/cst\\_systems.php](http://www.greenrhinoenergy.com/solar/technologies/cst_systems.php), Accessed 27 May 2012.
- [gse12]** GSE Group: Osservatorio Statistico, <http://www.gse.it/it/Dati%20e%20Bilanci/Osservatorio%20statistico/Pages/default.aspx>, Accessed 18 July 2012.
- [gwe10]** Global Wind Energy Council: *Global Wind Energy Outlook 2010*, Report, October 2010.
- [haw06]** D. Hawkins, et al.: *Evolving Role of Wind Forecasting in Market Operation at the CAISO*, Power Systems Conference and Exposition, pp. 234-238, Atlanta/U.S.A, 29 October-1 November 2006.
- [hey12]** Homer Energy: <http://www.homerenergy.com>, Accessed 23 July 2012.
- [hol09]** H. Holttinen, et al. *Design and operation of power systems with large amounts of wind power*, Final report, IEA Wind Task 25, 2009.
- [hsh12]** Hong Shen: *Transmission of large scale wind power in China*. IEC Workshop on Grid Integration of Large-capacity Renewable Energy and Large-capacity Energy Storage, University of Colorado at Boulder, March 2012.
- [hts09]** Benjamin Kroposki, et al. *Harnessing the Sun: An Overview of Solar Technologies*, IEEE Power & Energy Magazine, 7(3), p22-33, May/June 2009.
- [iea09]** S. Inage: *Prospects for Large-Scale Energy Storage in Decarbonized Power Grids*, International Energy Agency Working Paper, 2009.
- [iea11]** Adam Brown, et al: *Renewable Energy: Markets and Prospects by Technology*, International Energy Agency Information Paper, 2011.
- [iig12]** Chen-Ching Liu, et al.: *Intruders in the Grid: Cyber-vulnerability and Mitigation Studies Using a SCADA Test Bed*. IEEE Power & Energy Magazine, 10(1), p58-66, Jan/Feb 2012.
- [jef11]** Jeff St. John: *Is Europe Ready for Automated Demand Response?*, Greentechmedia, 7 Oct 2011.
- [mei10]** P. Meibom, et al.: *Advanced Unit Commitment Strategies in the United States Eastern Interconnection*, 9th Annual International Workshop on Large-Scale Integration of Wind Power into Power Systems as well as on Transmission Networks for Offshore Wind Power Plants, Quebec/Canada, 18-19 October 2010.

- [mev09] M. Caramanis, et al.: *Management of Electric Vehicle Charging to Mitigate Renewable Generation Intermittency and Distribution Network Congestion*, Joint 48th IEEE Conference on Decision and Control and 28th Chinese Control Conference, 2009.
- [mfc11] Robert Zavadil, et al. *Models for Change: Ensuring System Reliability in the Age of Large Wind Power Plants*, IEEE Power & Energy Magazine, 9(6), p88-90, Nov/Dec 2011.
- [mit11] Massachusetts Institute of Technology: *The Future of The Electric Grid*, Report, 2011.
- [mlt10] G. Corso: *Multi-objective long term optimal dispatch of Distributed Energy Resources in micro-grids*, UPEC 2010.
- [mma11] Abraham Ellis, et al.: *Model Makers: Simulating PV Systems in Transmission and Distribution Planning*, IEEE Power & Energy Magazine, 9(3), p55-61, May/June 2011.
- [msb10] International Electrotechnical Commission Market Strategy Board: *Coping with the Energy Challenge: The IEC's role from 2010 to 2030*, White Paper, September 2010.
- [msb11] International Electrotechnical Commission Market Strategy Board: *Electrical Energy Storage*, White Paper, December 2011.
- [ner09] North American Electric Reliability Corporation, Integration of Variable Generation Task Force: *Accommodating High Levels of Variable Generation*, Report, April 2009.
- [ner10] North American Electric Reliability Corporation, Integration of Variable Generation Task Force: *Flexibility Requirements and Metrics for Variable Generation*, Report, Aug 2010.
- [npg10] Northwest Power Grid, State Grid Corporation of China: *Power Demand Forecast, Power and Electricity Balancing, and Load Following Capability Analysis of the Northwest Power Grid in the 12th Five-year Plan Period*, Report, 2010, in Chinese.
- [obo12] 1BOG Blog, *How Solar Feed-in Tariffs (FITs) Work*, <http://solarfinancing.1bog.org/feed-in-tariffs/>, Accessed 13 Feb 2012.
- [oma11] R. Banos, et al.: *Optimization methods applied to renewable and sustainable energy: A Review*, Renewable and Sustainable Energy Reviews 15 (2011) p1753-1766.
- [opp11] North American Electric Reliability Corporation, Integration of Variable Generation Task Force: *Operating Practices, Procedures, and Tools*, Report, Mar 2011.
- [ops08] P.D. Brown: *Optimization of Pumped Storage Capacity in an Isolated Power System with Large Renewable Penetration*, IEEE Transactions on Power Systems 23 (2008), p523-531.
- [pao11] John H Kehler, et al.: *Planning and Operational Considerations for Power System Flexibility*, IEEE PES General Meeting Power System Flexibility Panel, 2011.
- [pei12] Richard Piwko, et al.: *Penetrating Insights: Lessons Learned from Large-Scale Wind Power Integration*, IEEE Power & Energy Magazine, 10(2), p44-52, Mar/Apr 2012.
- [per11] I. Perez-Arriaga: *Managing Large Scale Penetration of Intermittent Renewables*, MITEL Symposium on Managing Large-Scale Penetration of Intermittent Renewables, Cambridge/ U.S.A, 20 April 2011.
- [pts11] Wenuan Li: *Probabilistic Transmission System Planning*, Book, IEEE-Press, 2011.



- [rep11]** Renewable Energy Policy Network for the 21st Century: *Renewables 2011 Global Status Report*, Report, July 2011.
- [rvp08]** C.C. Wu, et al.: *Role and Value of Pumped Storage Units in an Ancillary Services Market for Isolated Power Systems – Simulation in the Taiwan Power System*, IEEE Transactions of Industry Applications, 44(6), Nov/Dec 2008.
- [sad11]** Lawrence E. Jones: *Strategies and Decision Support System for Integrating Variable Resources in Control Centers for Reliable Grid Operations: Global Best Practices, Examples of Excellence and Lessons Learned*, Report, Alstom Grid Inc., 2011.
- [sco12]** J. Hill, et al.: *System constraints on optimal dispatch schedule for battery storage systems*, IEEE PES Innovative Smart Grid Technologies 2012.
- [sgc07]** Webpage: <http://www.sgcc.com.cn/dlkp/dlhb/kpzs/sbdssjbzs/61089.shtml>, Accessed 11 March 2012.
- [sgc11]** State Grid Corporation of China: *Promoting Wind Power Development in China*, White Paper, Apr 2011.
- [sgc12]** State Grid Corporation of China: <http://www.sgcc.com.cn/ywlm/mediacenter/corporatenews/04/245999.shtml>, Article 2011, Accessed 29 March 2012.
- [sge11]** State Grid Energy Research Institute, Vestas Wind Energy Technology (China): *Integrated Solution Strategies for Coordinated Wind Power and Grid Development-International Experiences and China Practices*, Report, Oct 2011.
- [sic12]** Julie Hull, et al.: *Staying in control: Cybersecurity and the Modern Electric Grid*, IEEE Power & Energy Magazine, 10(1), p41-48, Jan/Feb 2012.
- [sin06]** Webpage: <http://finance.sina.com.cn/roll/20061201/09091074144.shtml>, Accessed 15 April 2012.
- [sin12]** Ivan M. Dudurych, et al.: *Safety in Numbers: Online Security Analysis of Power Grids with High Wind Penetration*, IEEE Power & Energy Magazine, 10(2), p62-70, Mar/Apr 2012.
- [smp11]** J. Smith, B. Parsons: *Wind Integration: Much Has Changed in Two Years*, IEEE Power & Energy Magazine, 9(6), p18-25, Nov/Dec 2011.
- [sra12]** North American Electric Reliability Corporation, Integration of Variable Generation Task Force: *Special Reliability Assessment: Interconnection Requirements for Variable Generation*, Report, Mar 2012.
- [tea07]** Mukhopadhyay S.: *Towards electricity for all: transmission planning for the growth of India's power system*, IEEE Power & Energy Magazine, 5(3), p71-78, May/June 2007.
- [tec10]** C. Quinn, D. Zimmerle, T.H. Bradley: *The effect of communication architecture on the availability, reliability, and economics of plug-in hybrid electric vehicle-to-grid ancillary services*, Journal of Power Sciences 195 (2010), p1500-1509.
- [tem12]** Taiwan Electrical and Mechanical Engineering Services (TEMES): [www.temes.com.tw/Item03\\_EN.htm](http://www.temes.com.tw/Item03_EN.htm), Accessed 23 July 2012.

- [tgs12]** Mark Reynolds, et al.: *The Golden Spike: Advanced Power Electronics Enables Renewable Development Across NERC Regions*, IEEE Power & Energy Magazine, 10(2), p71-78, Mar/Apr 2012.
- [tgy06]** Webpage: <http://www.sgcc.com.cn/ztlz/tgyzl/tgyzs/default.shtml>, Accessed 15 April 2012.
- [tie12]** Webpage: <http://www.3tier.com/en/>, Accessed 29 March 2012.
- [top12]** Daniel E. Nordell: Terms of Protection: The Many Faces of Smart Grid Security, IEEE Power & Energy Magazine, 10(1), p18-23, Jan/Feb 2012.
- [tpd11]** State Grid Corporation of China: Typical Design of Wind Farm Electrical Systems. China Electric Power Press, 2011, Book in Chinese.
- [tre10]** P. Denholm, E. Ela, B. Kirby, M. Milligan: *The Role of Energy Storage with Renewable Electricity Generation*, U.S. National Renewable Energy Laboratory Technical Report NREL/TP-6A2-47187, Report, 2010.
- [trp11]** Eamonn Lannoye, et al.: *The Role of Power System Flexibility in Generation Planning*, IEEE PES General Meeting Power System Flexibility Panel, 2011.
- [uei10]** The Union of the Electricity Industry: *Integrating Intermittent Renewable Sources in the EU Electricity System by 2020: Challenges and Solutions*, Report, 2010.
- [vce03]** G. Bathurst, G. Strbac: *Value of Combining Energy Storage and Wind in Short-term Energy and Balancing Markets*, Electric Power Systems Research 67 (2003), p1-8.
- [vsc10]** Guangfu Tang: *VSC-HVDC Based High Voltage DC Transmission Technology*, Book, China Electric Power Press, 2010, in Chinese.
- [wei11]** Liping Jiang, et al. *Wind Energy in China: Status and Prospects*, IEEE Power & Energy Magazine, 9(6), p36-46, Nov/Dec 2011.
- [weo11]** International Energy Agency: *World Energy Outlook 2011* © OECD/IEA 2011.
- [won11]** F. Wong, C. Yixin: [http://af.reuters.com/article/energyOilNews/idAFL3E7G5546\\_20110506](http://af.reuters.com/article/energyOilNews/idAFL3E7G5546_20110506), Article 2011, Accessed 29 March 2012.
- [wpa12]** Webpage Wind Powering America: [http://www.windpoweringamerica.gov/wind\\_installed\\_capacity.asp](http://www.windpoweringamerica.gov/wind_installed_capacity.asp), Accessed 29 March 2012.
- [yam11]** M. Yamamoto, O. Ikki: *Nation Survey Report of PV Power Applications in Japan*, Report, International Energy Agency, 17 June 2011.





INTERNATIONAL  
ELECTROTECHNICAL  
COMMISSION

3, rue de Varembé  
P.O. Box 131  
CH-1211 Geneva 20  
Switzerland

Tel.: +41 22 919 02 11  
Fax: +41 22 919 03 00  
info@iec.ch  
www.iec.ch

ISBN 978-2-8322-0340-8



CHF 50.-