

This is a preview of "BS EN 12566-6:2013". [Click here to purchase the full version from the ANSI store.](#)

BS EN 12566-6:2013



BSI Standards Publication

Small wastewater treatment systems for up to 50 PT

Part 6: Prefabricated treatment units for septic tank effluent

NO COPYING WITHOUT BSI PERMISSION EXCEPT AS PERMITTED BY COPYRIGHT LAW

raising standards worldwide™



This is a preview of "BS EN 12566-6:2013". [Click here to purchase the full version from the ANSI store.](#)

This British Standard is the UK implementation of EN 12566-6:2013.

The UK participation in its preparation was entrusted to Technical Committee B/505, Wastewater engineering.

A list of organizations represented on this committee can be obtained on request to its secretary.

This publication does not purport to include all the necessary provisions of a contract. Users are responsible for its correct application.

© The British Standards Institution 2013. Published by BSI Standards Limited 2013

ISBN 978 0 580 64231 9

ICS 13.060.30

Compliance with a British Standard cannot confer immunity from legal obligations.

This British Standard was published under the authority of the Standards Policy and Strategy Committee on 28 February 2013.

Amendments issued since publication

Date	Text affected
------	---------------

This is a preview of "BS EN 12566-6:2013". [Click here to purchase the full version from the ANSI store.](#)

EUROPÄISCHE NORM

February 2013

ICS 13.060.30

English Version

Small wastewater treatment systems for up to 50 PT - Part 6: Prefabricated treatment units for septic tank effluent

Petites installations de traitement des eaux usées jusqu'à
50 PTE - Partie 6: Unités préfabriquées de traitement des
effluents de fosses septiques

Kleinkläranlagen für bis zu 50 EW - Teil 6: Vorgefertigte
Anlagen für die weitergehende Behandlung des aus
Faulgruben ablaufenden Abwassers

This European Standard was approved by CEN on 7 December 2012.

CEN members are bound to comply with the CEN/CENELEC Internal Regulations which stipulate the conditions for giving this European Standard the status of a national standard without any alteration. Up-to-date lists and bibliographical references concerning such national standards may be obtained on application to the CEN-CENELEC Management Centre or to any CEN member.

This European Standard exists in three official versions (English, French, German). A version in any other language made by translation under the responsibility of a CEN member into its own language and notified to the CEN-CENELEC Management Centre has the same status as the official versions.

CEN members are the national standards bodies of Austria, Belgium, Bulgaria, Croatia, Cyprus, Czech Republic, Denmark, Estonia, Finland, Former Yugoslav Republic of Macedonia, France, Germany, Greece, Hungary, Iceland, Ireland, Italy, Latvia, Lithuania, Luxembourg, Malta, Netherlands, Norway, Poland, Portugal, Romania, Slovakia, Slovenia, Spain, Sweden, Switzerland, Turkey and United Kingdom.



EUROPEAN COMMITTEE FOR STANDARDIZATION
COMITÉ EUROPÉEN DE NORMALISATION
EUROPÄISCHES KOMITEE FÜR NORMUNG

Management Centre: Avenue Marnix 17, B-1000 Brussels

This is a preview of "BS EN 12566-6:2013". [Click here to purchase the full version from the ANSI store.](#)

Contents		Page
Foreword.....		4
1	Scope.....	6
2	Normative references.....	6
3	Terms and definitions	7
4	Symbols and abbreviations	8
5	Nominal designation	8
6	Requirements	8
6.1	Design.....	8
6.1.1	General	8
6.1.2	Overall dimensions	8
6.1.3	Inlets, outlets, internal pipework and connections.....	9
6.1.4	Access	9
6.2	Load bearing capacity.....	9
6.2.1	General	9
6.2.2	Load bearing capacity determined by calculation.....	10
6.2.3	Load bearing capacity determined by testing	10
6.3	Secondary treatment efficiency.....	11
6.3.1	General	11
6.3.2	Secondary treatment efficiency ratio	11
6.3.3	Micro-organism reduction	12
6.4	Watertightness	12
6.5	Power consumption	12
6.6	Durability	13
6.6.1	General	13
6.6.2	Concrete, steel, PVC-U, PE, GRP.....	13
6.6.3	PDCPD	13
6.6.4	Flexible sheets	13
6.7	Reaction to fire.....	14
6.7.1	General	14
6.7.2	Units classified as Class A1 without the need for testing.....	14
6.7.3	Units classified according to the test results	14
6.8	Dangerous substances	15
7	Evaluation of conformity.....	15
7.1	General	15
7.2	Initial type testing – Type testing	15
7.2.1	General	15
7.2.2	Sampling, testing and compliance criteria.....	17
7.2.3	Test reports	17
7.3	Factory production control (FPC).....	17
7.3.1	General	17
7.3.2	Requirements	17
7.3.3	Procedure for modifications	19
7.3.4	Initial inspection of factory and of FPC.....	20
7.3.5	Continuous surveillance of FPC.....	20
8	Marking.....	20
8.1	Marking of the unit	20
8.2	Technical information accompanying the unit	20
9	Installation instructions	21

This is a preview of "BS EN 12566-6:2013". [Click here to purchase the full version from the ANSI store.](#)

10	Operation and maintenance instructions	21
Annex A	(normative) Secondary treatment efficiency test procedure.....	23
A.1	Selection of the unit and its preliminary evaluation	23
A.1.1	General	23
A.1.2	Installation and commissioning.....	23
A.1.3	Operation and maintenance procedures during testing.....	23
A.1.4	Data to be monitored.....	23
A.2	Test procedure	24
A.2.1	Time for establishment	24
A.2.2	Influent characteristics	24
A.2.3	Daily flow pattern for testing.....	24
A.2.4	Test method.....	24
A.2.5	Influent and effluent sampling	26
A.3	Sample analysis	26
A.4	Test report	26
Annex B	(normative) Presentation of the micro-organisms test results	28
Annex C	(informative) Analysis method.....	29
Annex ZA	(informative) Clauses of this European Standard addressing the provisions of the EU	
	Construction Products Directive	30
ZA.1	Scope and relevant characteristics	30
ZA.2	Procedure of attestation of conformity of prefabricated secondary treatment units.....	32
ZA.2.1	Systems of attestation of conformity	32
ZA.2.2	EC certificate of conformity and EC declaration of conformity.....	34
ZA.3	CE marking and labelling.....	35
	Bibliography.....	38

This is a preview of "BS EN 12566-6:2013". [Click here to purchase the full version from the ANSI store.](#)

Foreword

This document (EN 12566-6:2013) has been prepared by Technical Committee CEN/TC 165 "Wastewater engineering", the secretariat of which is held by DIN.

This European Standard shall be given the status of a national standard, either by publication of an identical text or by endorsement, at the latest by August 2013, and conflicting national standards shall be withdrawn at the latest by August 2013.

Attention is drawn to the possibility that some of the elements of this document may be the subject of patent rights. CEN [and/or CENELEC] shall not be held responsible for identifying any or all such patent rights.

This document has been prepared under a mandate given to CEN by the European Commission and the European Free Trade Association, and supports essential requirements of EU Directive(s).

For relationship with EU Directive(s), see informative Annex ZA, which is an integral part of this document.

The standard series EN 12566 "*Small wastewater treatment systems for up to 50 PT*" contains the following parts (see Figure 1):

- *Part 1: Prefabricated septic tanks*
- *Part 3: Packaged and/or site assembled domestic wastewater treatment plants*
- *Part 4: Septic tanks assembled in situ from prefabricated kits*
- *Part 6: Prefabricated treatment units for septic tank effluent* (the present document)
- *Part 7: Prefabricated tertiary treatment units* (in preparation)

For filtration and infiltration systems, CEN/TC 165 decided to publish the following CEN Technical Reports, which are considered as Code of Practices and do not specify treatment requirements:

- CEN/TR 12566-2, *Small wastewater treatment systems for up to 50 PT — Part 2: Soil infiltration systems*
- CEN/TR 12566-5, *Small wastewater treatment systems for up to 50 PT — Part 5: Pre-treated effluent filtration systems*

According to the CEN/CENELEC Internal Regulations, the national standards organisations of the following countries are bound to implement this European Standard: Austria, Belgium, Bulgaria, Croatia, Cyprus, Czech Republic, Denmark, Estonia, Finland, Former Yugoslav Republic of Macedonia, France, Germany, Greece, Hungary, Iceland, Ireland, Italy, Latvia, Lithuania, Luxembourg, Malta, Netherlands, Norway, Poland, Portugal, Romania, Slovakia, Slovenia, Spain, Sweden, Switzerland, Turkey and the United Kingdom.

This is a preview of "BS EN 12566-6:2013". Click here to purchase the full version from the ANSI store.

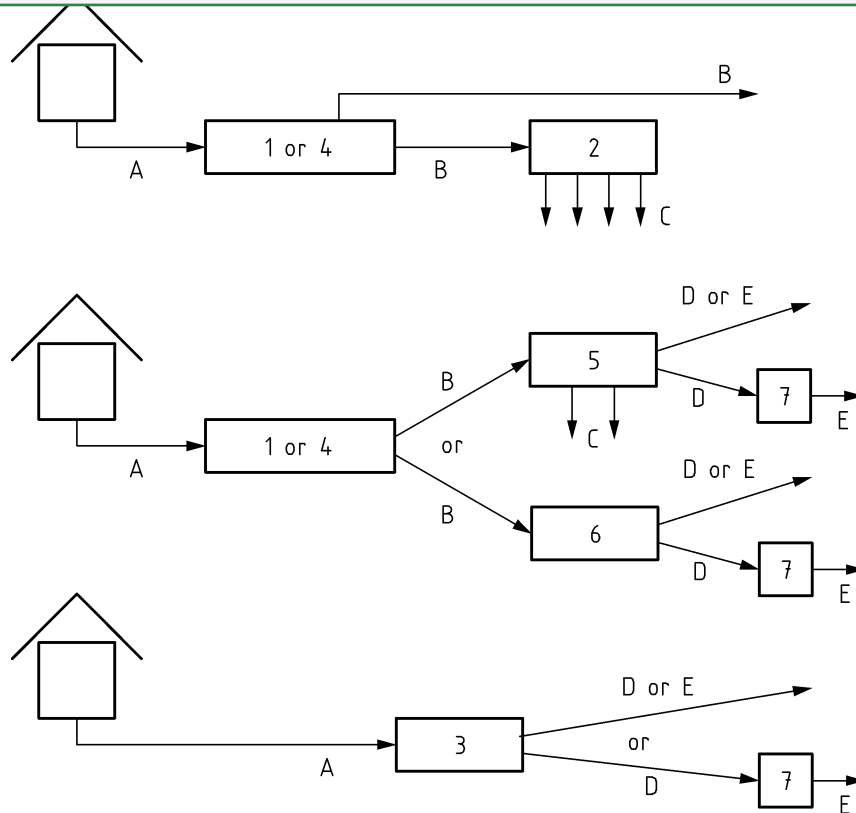

Key

- | | | | |
|---|------------------------------|---|--|
| A | raw domestic wastewater | 1 | prefabricated septic tank |
| B | septic tank effluent | 2 | soil infiltration system |
| C | treated infiltrated effluent | 3 | packaged and/or site assembled domestic wastewater treatment plant |
| D | treated wastewater | 4 | septic tank assembled in situ from prefabricated kit |
| E | tertiary treated wastewater | 5 | pre-treated effluent filtration system |
| | | 6 | prefabricated treatment unit used for septic tank effluent |
| | | 7 | prefabricated tertiary treatment unit |

Figure 1 — Scheme related to the arrangement of the parts of EN 12566 or CEN/TR 12566

NOTE National regulations may specify different arrangements between the products described in the series of EN 12566 and CEN/TR 12566.

This is a preview of "BS EN 12566-6:2013". [Click here to purchase the full version from the ANSI store.](#)

1 Scope

This European Standard specifies requirements, test methods, evaluation of conformity and marking for prefabricated secondary treatment units used for the treatment of effluent from septic tanks according to EN 12566-1 or EN 12566-4 in small wastewater treatment systems for up to 50 PT.

NOTE Equivalent septic effluent may come from existing septic tanks.

It applies to the prefabricated secondary treatment unit, where all its components are packaged or site-assembled and placed on the market as a kit by one manufacturer.

The prefabricated secondary treatment unit consists of one or more tanks made of concrete, steel, unplasticised polyvinylchloride (PVC-U), polyethylene (PE), glass reinforced polyester (GRP-UP), polypropylene (PP), polydicyclopentadiene (PDCPD) or container made of flexible sheets (PEHD, PP, PVC, EPDM). Other components specified by the manufacturer, such as pipes, pumps and filter material will be considered as part of the unit.

This standard establishes the performance of the prefabricated secondary treatment units needed to verify their suitability for the end use conditions for which the test methods are specified.

This standard applies for the packaged and/or site assembled secondary treatment units for use on the top of the ground (outside the building) or buried in the ground where no vehicle loads are applied to the unit.

This standard does not cover:

- non watertight secondary treatment units with direct infiltration into the ground;
- retrofit kits (see definition in 3.7).

2 Normative references

The following referenced documents, in whole or in part, are normatively referenced in this document and are indispensable for its application of this document. For dated references, only the edition cited applies. For undated references, the latest edition of the referenced document (including any amendments) applies.

EN 1085:2007, *Wastewater treatment — Vocabulary*

EN 12566-1, *Small wastewater treatment systems for up to 50 PT — Part 1: Prefabricated septic tanks*

EN 12566-3:2005+A1:2009, *Small wastewater treatment systems for up to 50 PT — Part 3: Packaged and/or site assembled domestic wastewater treatment plants*

EN 12566-4, *Small wastewater treatment systems for up to 50 PT — Part 4: Septic tanks assembled in situ from prefabricated kits*

EN 12311-2, *Flexible sheets for waterproofing — Determination of tensile properties — Part 2: Plastic and rubber sheets for roof waterproofing*

EN 13501-1, *Fire classification of construction products and building elements — Part 1: Classification using data from reaction to fire tests*

EN 14150, *Geosynthetic barriers — Determination of permeability to liquids*

EN ISO 527-1, *Plastics — Determination of tensile properties — Part 1: General principles (ISO 527-1)*

EN ISO 2555, *Plastics — Resins in the liquid state or as emulsions or dispersions — Determination of apparent viscosity by the Brookfield Test method (ISO 2555)*