

This is a preview of "BS EN 60728-11:2010". [Click here to purchase the full version from the ANSI store.](#)

BS EN 60728-11:2010



BSI Standards Publication

Cable networks for television signals, sound signals and interactive services

Part 11: Safety

bsi.

...making excellence a habit.™

This is a preview of "BS EN 60728-11:2010". [Click here to purchase the full version from the ANSI store.](#)

This British Standard is the UK implementation of EN 60728-11:2010. It is identical to IEC 60728-11:2010. It supersedes BS EN 60728-11:2005 which is withdrawn.

The UK participation in its preparation was entrusted by Technical Committee EPL/100, Audio, video and multimedia systems and equipment, to Subcommittee EPL/100/4, Cable distribution equipment and systems.

A list of organizations represented on this committee can be obtained on request to its secretary.

This publication does not purport to include all the necessary provisions of a contract. Users are responsible for its correct application.

© BSI 2010

ISBN 978 0 580 64910 3

ICS 33.060.40

Compliance with a British Standard cannot confer immunity from legal obligations.

This British Standard was published under the authority of the Standards Policy and Strategy Committee on 30 November 2010.

Amendments issued since publication

Amd. No.	Date	Text affected
-----------------	-------------	----------------------

This is a preview of "BS EN 60728-11:2010". [Click here to purchase the full version from the ANSI store.](#)

NORME EUROPÉENNE
EUROPÄISCHE NORM

October 2010

ICS 33.060.40

Supersedes EN 60728-11:2005

English version

**Cable networks for television signals, sound signals and interactive services -
Part 11: Safety
(IEC 60728-11:2010)**

Réseaux câblés pour les signaux de télévision, les signaux sonores et les services interactifs -
Partie 11: Sécurité
(CEI 60728-11:2010)

Kabelnetze für Fernsehsignale, Tonsignale und interaktive Dienste -
Teil 11: Sicherheitsanforderungen
(IEC 60728-11:2010)

This European Standard was approved by CENELEC on 2010-10-01. CENELEC members are bound to comply with the CEN/CENELEC Internal Regulations which stipulate the conditions for giving this European Standard the status of a national standard without any alteration.

Up-to-date lists and bibliographical references concerning such national standards may be obtained on application to the Central Secretariat or to any CENELEC member.

This European Standard exists in three official versions (English, French, German). A version in any other language made by translation under the responsibility of a CENELEC member into its own language and notified to the Central Secretariat has the same status as the official versions.

CENELEC members are the national electrotechnical committees of Austria, Belgium, Bulgaria, Croatia, Cyprus, the Czech Republic, Denmark, Estonia, Finland, France, Germany, Greece, Hungary, Iceland, Ireland, Italy, Latvia, Lithuania, Luxembourg, Malta, the Netherlands, Norway, Poland, Portugal, Romania, Slovakia, Slovenia, Spain, Sweden, Switzerland and the United Kingdom.

CENELEC

European Committee for Electrotechnical Standardization
Comité Européen de Normalisation Electrotechnique
Europäisches Komitee für Elektrotechnische Normung

Management Centre: Avenue Marnix 17, B - 1000 Brussels

This is a preview of "BS EN 60728-11:2010". [Click here to purchase the full version from the ANSI store.](#)

Foreword

The text of document 100/1679/FDIS, future edition 3 of IEC 60728-11, prepared by IEC TC 100, Audio, video and multimedia systems and equipment, was submitted to the IEC-CENELEC parallel vote and was approved by CENELEC as EN 60728-11 on 2010-10-01.

This European Standard supersedes EN 60728-11:2005.

EN 60728-11:2010 includes the following significant technical changes with respect to EN 60728-11:2005.

- The list of "differences in some countries" was transferred from the "Foreword" to informative Annex D.
- Some new terms and definitions were added.
- All Figures were reworked among other things concerning equipotential bonding and earthing details and were incorporated in the text at the appropriate places.
- Clause 11 "Protection against atmospheric overvoltages and elimination of potential differences" was completely reworked and re-structured taking into account among other things the provisions and requirements of the EN 62305 series on "Lightning protection".
- New informative Annex A on "Earth loop impedance" was added.
- New informative Annex C on "Examples of calculation of risk due to lightning" was added.
- Former Annex B on "Special conditions using IT power line networks" was re-worded and incorporated in Annex ZA as "Special National Condition in Norway".

Attention is drawn to the possibility that some of the elements of this document may be the subject of patent rights. CEN and CENELEC shall not be held responsible for identifying any or all such patent rights.

The following dates were fixed:

- | | | |
|--|-------|------------|
| – latest date by which the EN has to be implemented at national level by publication of an identical national standard or by endorsement | (dop) | 2011-07-01 |
| – latest date by which the national standards conflicting with the EN have to be withdrawn | (dow) | 2013-10-01 |

For this European Standard the informative Annex D of IEC 60728-11:2010 shall be disregarded and has been replaced by the informative Annexes ZA, *Special National Conditions*, and ZB, *A deviations*.

Annexes ZA, ZB, and ZC have been added by CENELEC.

Endorsement notice

The text of the International Standard IEC 60728-11:2010 was approved by CENELEC as a European Standard without any modification.

In the official version, for Bibliography, the following notes have to be added for the standards indicated:

IEC 60728-1	NOTE Harmonized as EN 60728-1.
-------------	--------------------------------

This is a preview of "BS EN 60728-11:2010". [Click here to purchase the full version from the ANSI store.](#)

And the following annexes:

Annex ZA (normative)

Special national conditions

Special national condition: National characteristic or practice that cannot be changed even over a long period, e.g. climatic conditions, electrical earthing conditions.

NOTE If it affects harmonization, it forms part of the European Standard.

For the countries in which the relevant special national conditions apply these provisions are normative, for other countries they are informative.

Clause Special National Condition

6.2 ZA.1 Norway

The following parts of the standard are not applicable due to Special National Conditions:

- For new and rebuilt coaxial electronic communication networks the outer conductor of the coaxial cable leading into a building shall be galvanic and isolated from the outer conductor of the coaxial cable inside the building;
- Examples of installations inside buildings described in 6.2g, 6.2i, 6.2l and shown in Figure 2, Figure 4, Figure 5 and Figure 7 shall be equipped with a galvanic isolator separating local earth from the cable network distribution lines;
- Galvanic isolators shall withstand the following requirements:
- Applying a 50 Hz AC voltage of 300 V_{RMS} between the input and the output of the outer conductor of the galvanic isolator for a period of not less than 20 min, the leakage current shall not exceed 8 mA_{RMS}. Applying a continuous DC voltage of 2 120 V between the input and the output of the outer conductor of the galvanic isolator for a period of not less than 1 min, the leakage current shall not exceed 0,7 mA.

It shall not be possible to touch metallic parts of the galvanic isolator when connected.

6.3 ZA.2 Norway

ZA.2.1 Justification

In most parts of Norway, the AC mains power are built as an IT- or TT-network with a line-to-line voltage of 230 V (see Figure ZA.1).

These types of networks have no N-conductor, and the AC mains power is supplied to the equipment from two of the three line conductors (IEC 60950-1:2005, Annex V).

This is a preview of "BS EN 60728-11:2010". Click here to purchase the full version from the ANSI store.

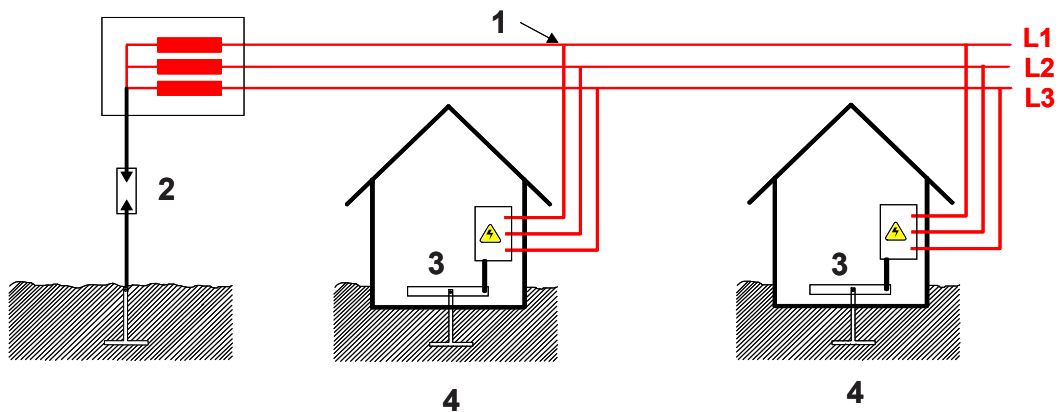

1 AC power distribution, IT system, line-to-line voltage 230 V	2 Voltage limiter
3 Equipotential bonding bar	4 Earth electrode

Figure ZA.1 – IT power distribution system in Norway

For a cable network covering an area with this type of power supply networks, special initiative should be taken to ensure that safety in the cable network is maintained. The following equipotential bonding arrangements described will provide necessary safety in such a network.

ZA.2.2 Equipotential bonding mechanism for cable networks

ZA.2.2.1 Installations in the vicinity of transformer stations

Any earth electrode in a cable network shall preferably be located at a minimum distance of 20 m from the nearest earth electrode in a high-power transformer station (high to mains voltage) (see Figure ZA.2 and ITU-T K.8 or EN 50174-3).

If the above-mentioned distance is less than 20 m, all equipment in the cable network shall be electrically isolated from local earth by mounting the equipment within a non-metallic enclosure, as shown in Figure ZA.3. Mains powered equipment with local power feeding should not be used in this case.

Before any work on the installation is started, measurements shall be carried out to reveal if there are any hazardous voltages between local earth and the earth for the cable network.

The safety sign "Warning about hazardous electrical voltage"  according to sign 7.4 of ISO 3864-1:2002 shall be attached to the non-metallic enclosure.

ZA.2.2.2 Cabinets for cable networks located near cabinets/ installations for mains

Cabinets for cable networks placed together with cabinets for mains power distributions should preferably be placed at a minimum of 2 m apart. If the distance is closer than 2 m, a common earth electrode between the cabinets shall be used. Examples of such installations are shown in Figure ZA.4, Figure ZA.5, Figure ZA.6 and Figure ZA.7.

This is a preview of "BS EN 60728-11:2010". Click here to purchase the full version from the ANSI store.

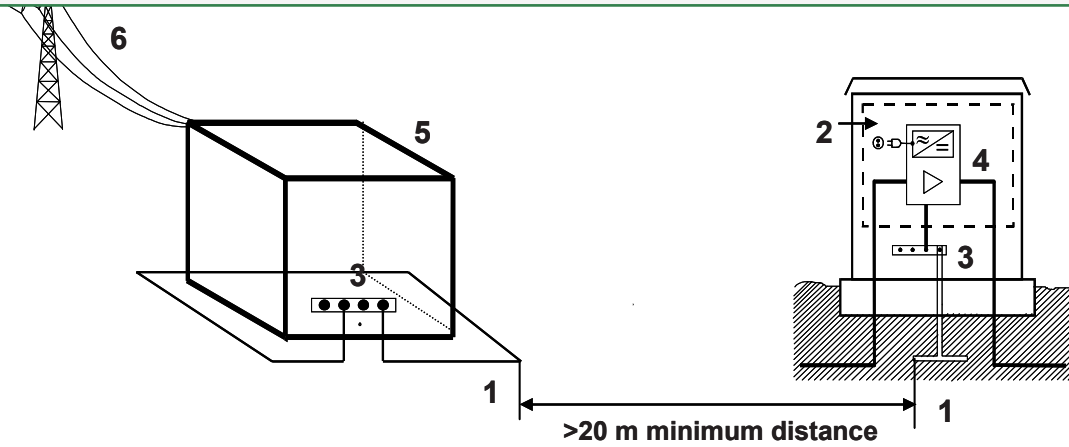

1 Earth electrode	2 Non-metallic enclosure
3 Equipotential bonding bar	4 Mains supplied equipment
5 Transforming station	6 High-voltage power transmission system

Figure ZA.2 – Example of installations located farther than 20 m away from a transforming station

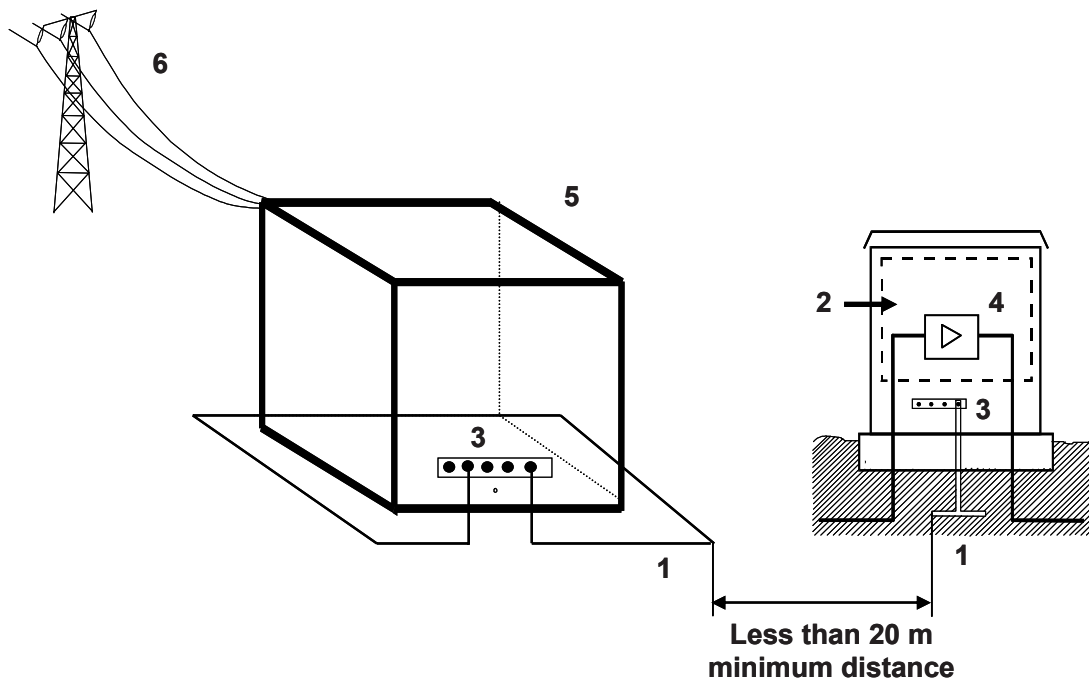

1 Earth electrode	2 Non-metallic enclosure
3 Equipotential bonding bar	4 Remotely supplied equipment
5 Transforming station	6 High-voltage power transmission system

Figure ZA.3 – Example of installations located closer than 20m from a transforming station

This is a preview of "BS EN 60728-11:2010". Click here to purchase the full version from the ANSI store.

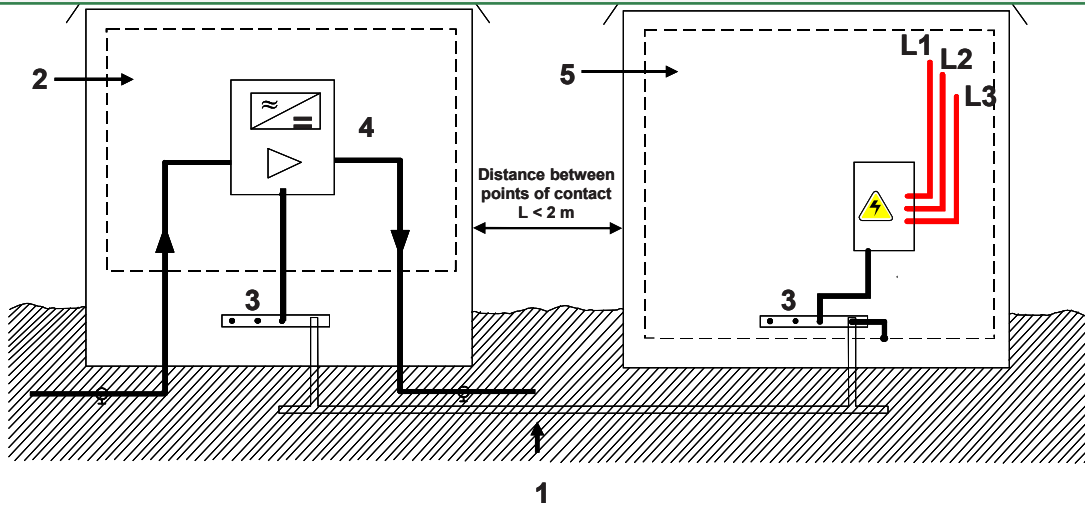

1 Common earth electrode	2 Non-metallic enclosure
3 Equipotential bonding bar	4 Mains supplied equipment
5 Metallic enclosure	

Figure ZA.4 – Example of cabinets for cable network with locally fed equipment and mains placed less than 2 m apart

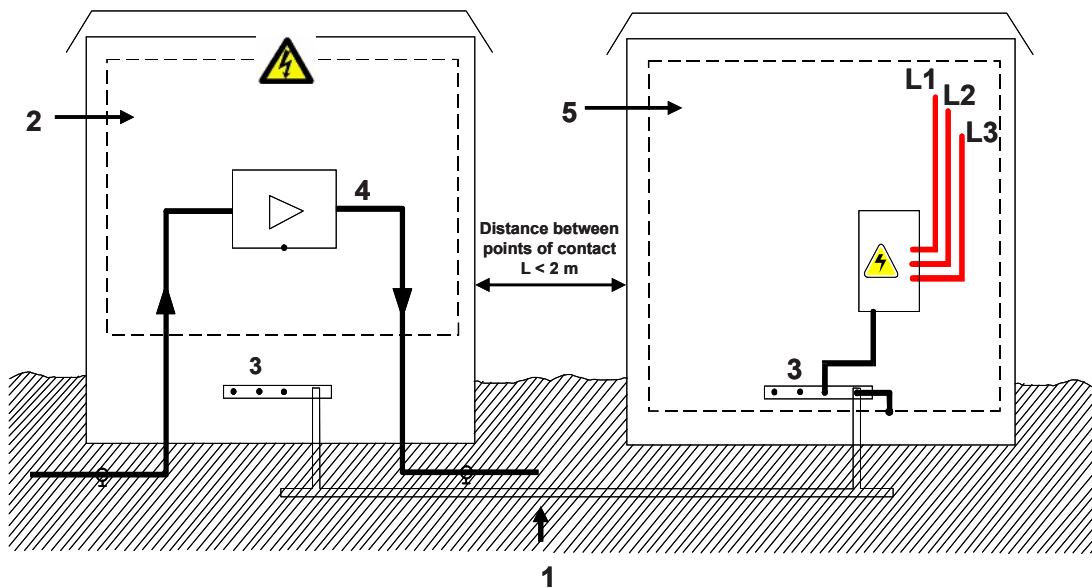

1 Common earth electrode	2 Non-metallic enclosure
3 Equipotential bonding bar	4 Remotely supplied equipment
5 Metallic enclosure	

Figure ZA.5 – Example of cabinets for cable network with remotely fed equipment and mains placed less than 2 m apart

This is a preview of "BS EN 60728-11:2010". Click here to purchase the full version from the ANSI store.

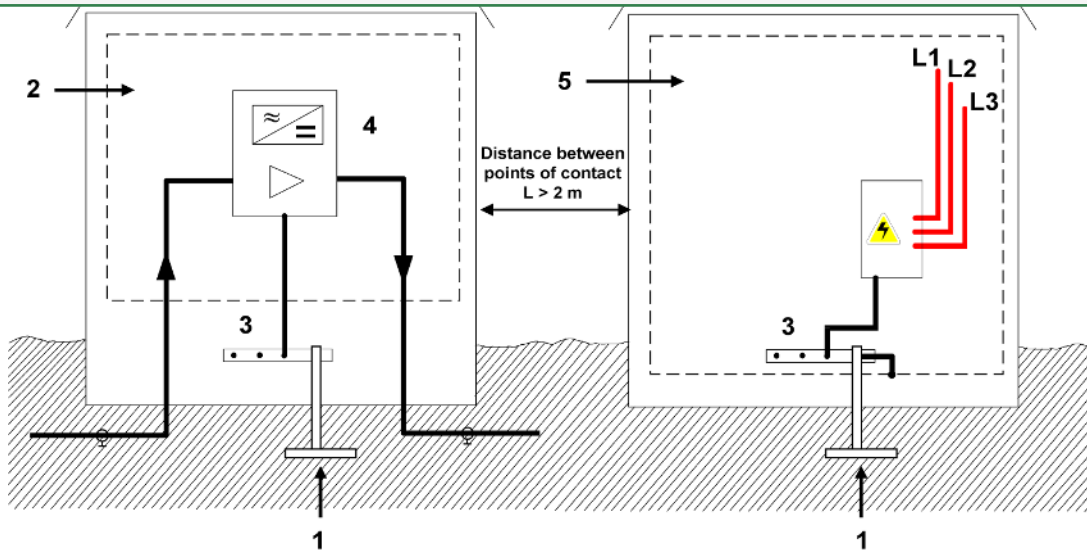

1 Earth electrode	2 Non-metallic enclosure
3 Equipotential bonding bar	4 Mains supplied equipment
5 Metallic enclosure	

Figure ZA.6 – Example of cabinets for cable network with locally fed equipment and mains placed more than 2 m apart

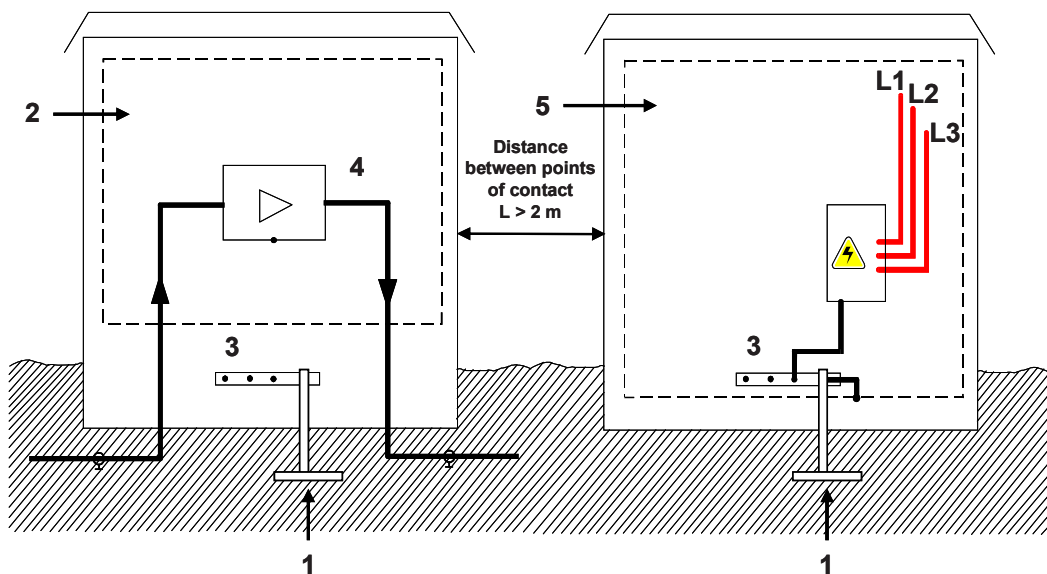

1 Earth electrode	2 Non-metallic enclosure
3 Equipotential bonding bar	4 Remotely supplied equipment
5 Metallic enclosure	

Figure ZA.7 – Example of cabinets for cable network with remotely fed equipment and mains placed more than 2m apart

This is a preview of "BS EN 60728-11:2010". [Click here to purchase the full version from the ANSI store.](#)

ZA.2.3 Use of galvanic isolation in a cable network with remote power-feeding

When using galvanic isolation in cable networks with remote power feeding, the amplifier shall be placed in front of the galvanic isolator as shown in Figure ZA.8.

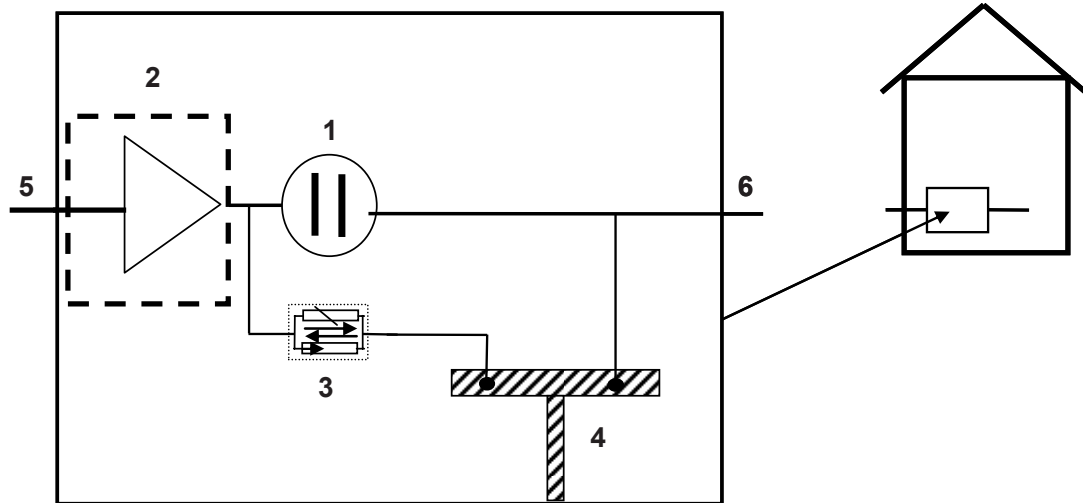

1 Galvanic isolator	2 Non-metallic enclosure
3 Voltage dependent protection device	4 Common earth electrode
5 CATV system	6 House internal cable-TV network

Figure ZA.8 – Example of an installation placing the amplifier in front of the galvanic isolator

A voltage dependent protective device is recommended in order to protect the galvanic isolator from transient voltages.

The amplifier shall be electrically isolated from the local electrical earth. In case the amplifier is mounted close to either local electrical earth or installations connected to local electrical earth, the amplifier shall be placed in such a way that it is not possible to physically touch both the amplifier and the installation without having to remove a cover or other safety arrangements. The covers and amplifiers shall be labelled with the safety sign given under ZA.2.2.1. The covers used shall be designed in such a way that they can only be removed using a key or a special tool.

ZA.2.4 Use of voltage dependent protective device in a cable network.

Network, property and health shall be protected against failure in isolation between infrastructures with different levels of voltage and other unwanted high voltages caused by any kind of high voltage distribution networks or atmospheric discharges.

Depending on the voltages time span, all voltages with local earth as a reference shall be limited according to following values:

0 to 200 ms	1 030 V
201 to 350 ms	780 V
351 to 500 ms	650 V
501 to 1 000 ms	430 V
1 001 to 2 000 ms	300 V
2 001 to 3 000 ms	250 V

This is a preview of "BS EN 60728-11:2010". [Click here to purchase the full version from the ANSI store.](#)

0 001 to 0 000 ms	200 V
5 001 to 10 000 ms	150 V
More than 10 000 ms	60 V

In Norway, network installations with no mains supplied equipment are usually installed isolated from local earth due to difficult ground conditions. When calculations show that the voltage level will rise above 650 V, measures must be taken to reduce the voltage level. This can be done by connecting a voltage dependent device between the network installation and local earth. The voltage dependent device must not connect the installations to local earth in case of a short circuit in mains power.

This implies a safe threshold voltage of 420 V.

Examples of protections using a voltage depending device are shown in Figure 3 and Figure ZA.9.

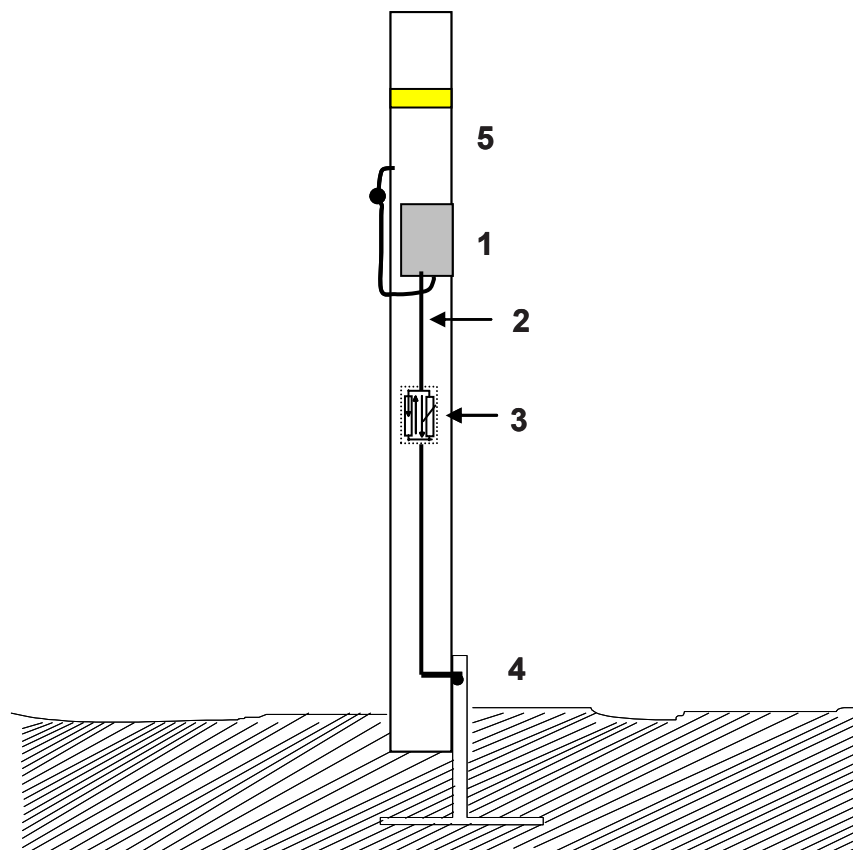

1 Amplifier / passive equipment	2 Equipotential bonding conductor
3 Voltage dependent protection device	4 Common earth electrode
5 Pylon	

Figure ZA.9 – Example of protection using a voltage depending device on network installations on poles

12.3 ZA.3 Finland

The required wind pressure value is 700 N/m² for buildings up to 30 m.

This is a preview of "BS EN 60728-11:2010". [Click here to purchase the full version from the ANSI store.](#)

ANNEX ZB (informative)

A-deviations

A-deviation: National deviation due to regulations, the alteration of which is for the time being outside the competence of the CENELEC national member.

This European Standard falls under Directive 2006/95/EC.

NOTE (from CEN/CENELEC IR Part 2:2002, 2.17) Where standards fall under EC Directives, it is the view of the Commission of the European Communities (OJ No C 59, 1982-03-09) that the effect of the decision of the Court of Justice in case 815/79 Cremonini/Vrankovich (European Court Reports 1980, p. 3583) is that compliance with A-deviations is no longer mandatory and that the free movement of products complying with such a standard should not be restricted except under the safeguard procedure provided for in the relevant Directive.

A-deviations in an EFTA-country are valid instead of the relevant provisions of the European Standard in that country until they have been removed.

<u>Clause</u>	<u>Deviation</u>
---------------	------------------

9	ZB.1 France
----------	--------------------

(Arrêté interministériel, 2 April 1991)

This regulation specifies, among many other parameters, the minimum distance between electric supply wires (isolated and not isolated, low-voltage and high-voltage) and any other installation (e.g. buildings, antennas, telecommunication lines, etc.).

The main clauses of this regulation which concern the cable networks are Clauses 12, 25, 26, 33, 33bis, 38, 49, 51, 52 and 63.

Clause 9 of this standard specifies distances of 10 mm (indoors) and 20 mm (outdoors) and this is not sufficient to cover overhead cables. As an example, the minimum distance between an overhead telecommunication line and an overhead low-voltage (up to 1 kV) electricity supply line shall be 1 m (Clause 33). This distance may be reduced under specified conditions (Clauses 51, 52 and 63).

This regulation specifies also the minimum distance from high-voltage lines. This distance varies from 1 m to 4 m depending on the voltage, on the isolation of the cable and on the location (built-up area or not) (Clauses 33 and 63)

10.1	ZB.2 United Kingdom
-------------	----------------------------

In the UK the use of fully isolated system outlets is obligatory under the terms of the cable operating licence.

11	ZB.3 France
-----------	--------------------

(NF C 15100 - Décret n° 84-74 du 26 janvier 1984 modifié)

The use of TT distribution systems with 300 mA differential switching is not compatible with the interconnection of the earthing of two different buildings.

This is a preview of "BS EN 60728-11:2010". [Click here to purchase the full version from the ANSI store.](#)

Annex ZC (normative)

Normative references to international publications with their corresponding European publications

The following referenced documents are indispensable for the application of this document. For dated references, only the edition cited applies. For undated references, the latest edition of the referenced document (including any amendments) applies.

NOTE When an international publication has been modified by common modifications, indicated by (mod), the relevant EN/HD applies.

<u>Publication</u>	<u>Year</u>	<u>Title</u>	<u>EN/HD</u>	<u>Year</u>
-	-	Electrical installations of buildings - Protection against electromagnetic interferences (EMI) in installations of buildings	R 064-004	-
-	-	Coaxial cables	EN 50117	Series
-	-	Lightning Protection Components (LPC) - Part 1: Requirements for connection components	EN 50164-1	-
-	-	Lightning Protection Components (LPC) - Part 2: Requirements for conductors and earth electrodes	EN 50164-2	-
-	-	Information technology - Cabling installation - Part 2: Installation planning and practices inside buildings	EN 50174-2	-
-	-	Application of equipotential bonding and earthing in buildings with information technology equipment	EN 50310	-
IEC 60065 (mod)	2001	Audio, video and similar electronic apparatus - Safety requirements	EN 60065 + corr. August + A11	2002 2007 2008
IEC 60364	Series	Electrical installations of buildings	-	-
IEC 60364-1	-	Low-voltage electrical installations - Part 1: Fundamental principles, assessment of general characteristics, definitions	HD 60364-1	-
IEC 60364-5-52	-	Low-voltage electrical installations - Part 5-52: Selection and erection of electrical equipment - Wiring systems	HD 60364-5-52	-
IEC 60364-5-54	-	Electrical installations of buildings - Part 5-54: Selection and erection of electrical equipment - Earthing arrangements, protective conductors and protective bonding conductors	HD 60364-5-54	-
IEC 60529	-	Degrees of protection provided by enclosures (IP Code)	-	-
IEC 60617	-	Graphical symbols for diagrams	-	-
IEC 60825-1	-	Safety of laser products - Part 1: Equipment classification and requirements	EN 60825-1	2007

This is a preview of "BS EN 60728-11:2010". [Click here to purchase the full version from the ANSI store.](#)

<u>Publication</u>	<u>Year</u>	<u>Title</u>	<u>EN/IEC</u>	<u>Year</u>
IEC 60825-2	-	Safety of laser products - Part 2: Safety of optical fibre communication systems (OFCS)	EN 60825-2	-
IEC 60950-1 (mod)	2005	Information technology equipment - Safety - Part 1: General requirements	EN 60950-1 + A11	2006 2009
IEC 60990	-	Methods of measurement of touch current and protective conductor current	EN 60990	-
IEC 61140	2001	Protection against electric shock - Common aspects for installation and equipment	EN 61140	2002
IEC 62305	Series	Protection against lightning	EN 62305	Series
IEC 62305-2	2006	Protection against lightning - Part 2: Risk management	EN 62305-2 + corr. November	2006 2006
IEC 62305-3 (mod)	2006	Protection against lightning - Part 3: Physical damage to structures and life hazard	EN 62305-3 + corr. September + corr. November + A11	2006 2008 2006 2009
IEC 62305-4	-	Protection against lightning - Part 4: Electrical and electronic systems within structures	EN 62305-4	-
ISO 3864-1	2002	Graphical symbols - Safety colours and safety - signs - Part 1: Design principles for safety signs in workplaces and public areas		-

This is a preview of "BS EN 60728-11:2010". [Click here to purchase the full version from the ANSI store.](#)

CONTENTS

INTRODUCTION	7
1 Scope	8
2 Normative references	8
3 Terms, definitions, symbols and abbreviations	9
3.1 Terms and definitions	9
3.2 Symbols	15
3.3 Abbreviations	15
4 Fundamental requirements	16
4.1 General	16
4.2 Mechanical requirements	16
4.3 Accessible parts	16
4.4 Laser radiation	16
5 Protection against environmental influences	16
6 Equipotential bonding and earthing	17
6.1 General requirements	17
6.2 Equipotential bonding mechanisms	17
6.3 Equipotential bonding in meshed systems	26
6.3.1 References to other standards	26
6.3.2 General on AC mains	26
6.3.3 AC power distribution and connection of the protective conductor	26
6.3.4 Dangers and malfunction	27
6.3.5 Measures	27
7 Mains-supplied equipment	27
8 Remote power feeding in cable networks	28
8.1 Remote power feeding	28
8.1.1 Maximum allowed voltages	28
8.1.2 General requirements for equipment	28
8.1.3 Current-carrying capacity and dielectric strength of the components	28
8.2 Remote powering from subscriber premises	29
9 Protection against contact and proximity to electric power distribution systems	29
9.1 General	29
9.2 Overhead lines	29
9.2.1 Overhead lines up to 1 000 V	29
9.2.2 Overhead lines above 1 000 V	30
9.3 House installations up to 1 000 V	30
10 System outlets and transfer points	30
10.1 General	30
10.2 System outlet	31
10.2.1 Types of system outlets	31
10.2.2 Fully isolated system outlet	31
10.2.3 Semi-isolated system outlet	31
10.2.4 Non-isolated system outlet with protective element	31
10.2.5 Non-isolated system outlet without protective element	31
10.3 Transfer point	32
11 Protection against atmospheric overvoltages and elimination of potential differences	32

This is a preview of "BS EN 60728-11:2010". [Click here to purchase the full version from the ANSI store.](#)

11.1	General	32
11.2	Protection of the antenna system	33
11.2.1	Selection of appropriate methods for protection of antenna systems	33
11.2.2	Building equipped with a lightning protection system (LPS)	34
11.2.3	Building not equipped with an LPS	40
11.3	Earthing and bonding of the antenna system	44
11.3.1	Internal protection system	44
11.3.2	Earthing conductors	44
11.3.3	Earth termination system	47
11.4	Overvoltage protection	49
12	Mechanical stability	50
12.1	General requirements	50
12.2	Bending moment	50
12.3	Wind-pressure values	52
12.4	Mast construction	52
12.5	Data to be published	53
Annex A (informative)	Earth loop impedance	54
Annex B (informative)	Use of shield wires to protect installations with coaxial cables	57
Annex C (informative)	Examples of calculation of risk due to lightning	60
Annex D (informative)	The following differences exist in some countries	63
Bibliography	74
Figure 1	– Example of equipotential bonding and earthing of a metal enclosure	18
Figure 2	– Example of equipotential bonding	19
Figure 3	– Example of equipotential bonding and indirect earthing of the amplifier and the cables via a voltage-dependent protective device	20
Figure 4	– Example of equipotential bonding and earthing of a building installation (underground connection)	21
Figure 5	– Example of equipotential bonding and earthing of a building installation (above ground connection)	22
Figure 6	– Example of equipotential bonding with a galvanic isolated cable entering a building (underground connection)	23
Figure 7	– Example of maintaining equipotential bonding whilst a unit is removed	25
Figure 8	– Areas of antenna-outdoor-mounting on buildings, where earthing is not mandatory	33
Figure 9	– Flow chart for selection of the appropriate method for protecting the antenna system against atmospheric overvoltages	35
Figure 10	– Example of equipotential bonded headends and antennas in a protected volume of the building LPS	36
Figure 11	– Example of equipotential bonded headends and antennas in a protected volume of the building LPS	37
Figure 12	– Example of equipotential bonded headends and antennas in a protected volume of an external isolated ATS	38
Figure 13	– Example of equipotential bonded antennas (not installed in a protected volume) and headend with direct connection to building LPS	39
Figure 14	– Example of equipotential bonded headend and earthed antennas (building without LPS)	42
Figure 15	– Example of bonding for antennas and headend (building without LPS and lightning risk lower than or equal to the tolerable risk)	43

This is a preview of "BS EN 60728-11:2010". [Click here to purchase the full version from the ANSI store.](#)

Figure 16 – Example of protecting an antenna system (not installed in a protected volume) by additional discharge conductors ($R > R_T$)	46
Figure 17 – Examples of earthing mechanisms (minimum dimensions)	48
Figure 18 – Example of an overvoltage protective device for single dwelling unit	49
Figure 19 – Example of application of a coaxial overvoltage protective device for multiple dwelling unit	50
Figure 20 – Example of bending moment of an antenna mast	51
Figure A.1 – Systematic of earth loop resistance	55
Figure B.1 – Principle of single shield wire	59
Figure B.2 – Principle of two shield wires	59
Figure C.1 – Template for calculation of the risk due to lightning (Example No. 1)	60
Figure C.2 – Template for calculation of the risk due to lightning (Example No. 2)	62
Figure D.1 – IT power distribution system in Norway	64
Figure D.2 – Example of installations located farther than 20 m away from a transforming station	65
Figure D.3 – Example of installations located closer than 20m from a transforming station	65
Figure D.4 – Example of cabinets for cable network with locally fed equipment and mains placed less than 2 m apart	66
Figure D.5 – Example of cabinets for cable network with remotely fed equipment and mains placed less than 2 m apart	66
Figure D.6 – Example of cabinets for cable network with locally fed equipment and mains placed more than 2 m apart	67
Figure D.7 – Example of cabinets for cable network with remotely fed equipment and mains placed more than 2m apart	67
Figure D.8 – Example of an installation placing the amplifier in front of the galvanic isolator	68
Figure D.9 – Example of protection using a voltage depending device on network installations on poles	69
Figure D.10 – Example of the installation of a safety terminal in Japan	71
Figure D.11 – Examples of installation of a lightning protection system in Japan	72
Table 1 – Maximum allowed operation voltages and maximum allowed currents for coaxial cables in different cable network applications	29
Table 2 – Solutions for protection of antenna systems against atmospheric overvoltages	34
Table B.1 – Conductivity of different types of soil	57
Table B.2 – Protection factors (K_p) of protection measures against direct lightning strokes for buried cables	58

INTRODUCTION

Standards of the IEC 60728 series deal with cable networks including equipment and associated methods of measurement for headend reception, processing and distribution of television signals, sound signals and their associated data signals and for processing, interfacing and transmitting all kinds of signals for interactive services using all applicable transmission media.

This includes

- CATV networks,
- MATV networks and SMATV networks,
- individual receiving networks

and all kinds of equipment, systems and installations installed in such networks.

NOTE CATV encompasses the Hybrid Fibre Coaxial (HFC) networks used nowadays to provide telecommunications services, voice, data, audio and video both broadcast and narrowcast.

The extent of this standardization work is from the antennas, special signal source inputs to the headend or other interface points to the network up to the terminal input.

The standardization of any user terminals (i.e. tuners, receivers, decoders, terminals, etc.) as well as of any coaxial and optical cables and accessories thereof is excluded.

This is a preview of "BS EN 60728-11:2010". [Click here to purchase the full version from the ANSI store.](#)

CABLE NETWORKS FOR TELEVISION SIGNALS, SOUND SIGNALS AND INTERACTIVE SERVICES –

Part 11: Safety

1 Scope

This part of IEC 60728 deals with the safety requirements applicable to fixed sited systems and equipment. As far as applicable, it is also valid for mobile and temporarily installed systems, for example, caravans.

Additional requirements may be applied, for example, referring to

- electrical installations of buildings and overhead lines,
- other telecommunication services distribution systems,
- water distribution systems,
- gas distribution systems,
- lightning systems.

This standard is intended to provide specifically for the safety of the system, personnel working on it, subscribers and subscriber equipment. It deals only with safety aspects and is not intended to define a standard for the protection of the equipment used in the system.

2 Normative references

The following referenced documents are indispensable for the application of this document. For dated references, only the edition cited applies. For undated references, the latest edition of the referenced document (including any amendments) applies.

IEC 60065:2001, *Audio, video and similar electronic apparatus – Safety requirements*

IEC 60364 (all parts), *Low-voltage electrical installations*

IEC 60364-1, *Low-voltage electrical installations – Part 1: Fundamental principles, assessment of general characteristics, definitions*

IEC 60364-5-52, *Electrical installations of buildings – Part 5-52: Selection and erection of electrical equipment – Wiring systems*

IEC 60364-5-54, *Electrical installations of buildings – Part 5-54: Selection and erection of electrical equipment – Earthing arrangements, protective conductors and protective bonding conductors*

IEC 60529, *Degrees of protection provided by enclosures (IP Code)*

IEC 60617, *Graphical symbols for diagrams*

IEC 60825-1, *Safety of laser products – Part 1: Equipment classification and requirements*

IEC 60825-2, *Safety of laser products – Part 2: Safety of optical fibre communication systems (OFCS)*