



BSI Standards Publication

Image technology colour management — Architecture, profile format and data structure

Part 1: Based on ICC.1:2022

This is a preview of BS ISO 15076-1:2025. [Click here to purchase the full version from the ANSI store.](#)

National foreword

This British Standard is the UK implementation of ISO 15076-1:2025. It supersedes BS ISO 15076-1:2010, which is withdrawn.

The UK participation in its preparation was entrusted to Technical Committee PAI/43, Graphic technology.

A list of organizations represented on this committee can be obtained on request to its committee manager.

Contractual and legal considerations

This publication has been prepared in good faith, however no representation, warranty, assurance or undertaking (express or implied) is or will be made, and no responsibility or liability is or will be accepted by BSI in relation to the adequacy, accuracy, completeness or reasonableness of this publication. All and any such responsibility and liability is expressly disclaimed to the full extent permitted by the law.

This publication is provided as is, and is to be used at the recipient's own risk.

The recipient is advised to consider seeking professional guidance with respect to its use of this publication.

This publication is not intended to constitute a contract. Users are responsible for its correct application.

© The British Standards Institution 2025
Published by BSI Standards Limited 2025

ISBN 978 0 539 27501 8

ICS 37.100.99

Compliance with a British Standard cannot confer immunity from legal obligations.

This British Standard was published under the authority of the Standards Policy and Strategy Committee on 31 October 2025.

Amendments/corrigenda issued since publication

Date	Text affected
------	---------------



This is a preview of BS ISO 15076-1:2025. [Click here to purchase the full version from the ANSI store.](#)

ISO 15076-1**Image technology colour
management — Architecture,
profile format and data structure —****Part 1:
Based on ICC.1:2022**

*Gestion de couleur en technologie d'image — Architecture,
format de profil et structure de données —*

Partie 1: Sur la base de l'ICC.1:2022

**Third edition
2025-10**

This is a preview of BS ISO 15076-1:2025. [Click here to purchase the full version from the ANSI store.](#)



COPYRIGHT PROTECTED DOCUMENT

© ISO 2025

All rights reserved. Unless otherwise specified, or required in the context of its implementation, no part of this publication may be reproduced or utilized otherwise in any form or by any means, electronic or mechanical, including photocopying, or posting on the internet or an intranet, without prior written permission. Permission can be requested from either ISO at the address below or ISO's member body in the country of the requester.

ISO copyright office
CP 401 • Ch. de Blandonnet 8
CH-1214 Vernier, Geneva
Phone: +41 22 749 01 11
Email: copyright@iso.org
Website: www.iso.org

Published in Switzerland

This is a preview of BS ISO 15076-1:2025. [Click here to purchase the full version from the ANSI store.](#)

Foreword	vii
Introduction	viii
1 Scope	1
2 Normative references	1
3 Terms, definitions and abbreviated terms	2
3.1 Terms and definitions.....	2
3.2 Abbreviated terms.....	6
4 Basic number types	6
4.1 General.....	6
4.2 dateTimeNumber.....	6
4.3 float32Number.....	7
4.4 positionNumber.....	7
4.5 response16Number.....	7
4.6 s15Fixed16Number.....	8
4.7 u16Fixed16Number.....	8
4.8 u1Fixed15Number.....	8
4.9 u8Fixed8Number.....	8
4.10 uint16Number.....	8
4.11 uint32Number.....	8
4.12 uint64Number.....	9
4.13 uint8Number.....	9
4.14 XYZNumber.....	9
4.15 Seven-bit ASCII.....	9
5 Conformance	9
6 Profile connection space, rendering intents and device encoding	9
6.1 General considerations.....	9
6.2 Rendering intents.....	10
6.2.1 General.....	10
6.2.2 Media-relative colorimetric intents.....	10
6.2.3 ICC-absolute colorimetric intent.....	10
6.2.4 Perceptual intent.....	11
6.2.5 Saturation intent.....	11
6.3 Profile connection space.....	11
6.3.1 Chromatic adaptation.....	11
6.3.2 Colorimetric specification.....	11
6.3.3 Reference viewing environment and medium for the perceptual rendering intent.....	13
6.3.4 Colour space encodings for the PCS.....	15
6.4 Converting between PCSXYZ and PCSLAB encodings.....	17
6.5 Device encoding.....	18
7 Profile requirements	18
7.1 General.....	18
7.2 Profile header.....	20
7.2.1 General requirements.....	20
7.2.2 Profile size field (bytes 0 to 3).....	20
7.2.3 Preferred CMM type field (bytes 4 to 7).....	20
7.2.4 Profile version field (bytes 8 to 11).....	21
7.2.5 Profile/device class field (bytes 12 to 15).....	21
7.2.6 Data colour space field (bytes 16 to 20).....	21
7.2.7 PCS field (bytes 20 to 23).....	22
7.2.8 Date and time field (bytes 24 to 35).....	22
7.2.9 Profile file signature field (bytes 36 to 39).....	22
7.2.10 Primary platform field (bytes 40 to 43).....	22

This is a preview of BS ISO 15076-1:2025. [Click here to purchase the full version from the ANSI store.](#)

	7.2.13	Device model field (bytes 52 to 55).....	23
	7.2.14	Device attributes field (bytes 56 to 63).....	23
	7.2.15	Rendering intent field (bytes 64 to 67).....	23
	7.2.16	PCS illuminant field (Bytes 68 to 79).....	24
	7.2.17	Profile creator field (bytes 80 to 83).....	24
	7.2.18	Profile ID field (bytes 84 to 99).....	24
	7.2.19	Reserved field (bytes 100 to 127).....	24
7.3		Tag table.....	24
	7.3.1	Overview.....	24
	7.3.2	Tag count (byte position 0 to 3).....	25
	7.3.3	Tag signature (byte position 4 to 7 and repeating).....	25
	7.3.4	Offset to beginning of tag data element (byte position 8 to 11 and repeating).....	25
	7.3.5	Tag data element size (byte position 12 to 15 and repeating).....	25
7.4		Tag data.....	26
8		Required tags.....	26
	8.1	General.....	26
	8.2	Common requirements.....	26
	8.3	Input profiles.....	26
	8.3.1	General.....	26
	8.3.2	N-component LUT-based Input profiles.....	27
	8.3.3	Three-component matrix-based Input profiles.....	27
	8.3.4	Monochrome Input profiles.....	27
	8.4	Display profiles.....	28
	8.4.1	General.....	28
	8.4.2	N-Component LUT-based Display profiles.....	28
	8.4.3	Three-component matrix-based Display profiles.....	28
	8.4.4	Monochrome Display profiles.....	28
	8.5	Output profiles.....	29
	8.5.1	General.....	29
	8.5.2	N-component LUT-based Output profiles.....	29
	8.5.3	Monochrome Output profiles.....	29
	8.6	DeviceLink profile.....	29
	8.7	ColorSpace profile.....	30
	8.8	Abstract profile.....	30
	8.9	NamedColor profile.....	31
	8.10	Precedence order of tag usage.....	31
	8.10.1	General.....	31
	8.10.2	Input, display, output or colour space profile types.....	31
	8.10.3	DeviceLink or Abstract profile types.....	31
9		Tag definitions.....	32
	9.1	General.....	32
	9.2	Tag listing.....	33
	9.2.1	AToB0Tag.....	33
	9.2.2	AToB1Tag.....	33
	9.2.3	AToB2Tag.....	33
	9.2.4	blueMatrixColumnTag.....	33
	9.2.5	blueTRCTag.....	33
	9.2.6	BToA0Tag.....	34
	9.2.7	BToA1Tag.....	34
	9.2.8	BToA2Tag.....	34
	9.2.9	BToD0Tag.....	34
	9.2.10	BToD1Tag.....	34
	9.2.11	BToD2Tag.....	34
	9.2.12	BToD3Tag.....	35
	9.2.13	calibrationDateTimeTag.....	35
	9.2.14	charTargetTag.....	35

This is a preview of BS ISO 15076-1:2025. [Click here to purchase the full version from the ANSI store.](#)

9.2.17	cicpTag	36
9.2.18	colorantOrderTag	36
9.2.19	colorantTableTag	36
9.2.20	colorantTableOutTag	37
9.2.21	colorimetricIntentImageStateTag	37
9.2.22	copyrightTag	39
9.2.23	deviceMfgDescTag	39
9.2.24	deviceModelDescTag	39
9.2.25	DToB0Tag	39
9.2.26	DToB1Tag	39
9.2.27	DToB2Tag	39
9.2.28	DToB3Tag	40
9.2.29	gamutTag	40
9.2.30	grayTRCTag	40
9.2.31	greenMatrixColumnTag	40
9.2.32	greenTRCTag	40
9.2.33	luminanceTag	40
9.2.34	measurementTag	41
9.2.35	metadataTag	41
9.2.36	mediaWhitePointTag	41
9.2.37	namedColor2Tag	41
9.2.38	outputResponseTag	41
9.2.39	perceptualRenderingIntentGamutTag	42
9.2.40	preview0Tag	42
9.2.41	preview1Tag	42
9.2.42	preview2Tag	42
9.2.43	profileDescriptionTag	43
9.2.44	profileSequenceDescTag	43
9.2.45	profileSequenceIdentifierTag	43
9.2.46	redMatrixColumnTag	43
9.2.47	redTRCTag	43
9.2.48	saturationRenderingIntentGamutTag	43
9.2.49	technologyTag	44
9.2.50	viewingCondDescTag	44
9.2.51	viewingConditionsTag	45
10	Tag type definitions	45
10.1	General	45
10.2	chromaticityType	45
10.3	cicpType	46
10.4	colorantOrderType	47
10.5	colorantTableType	48
10.6	curveType	48
10.7	dataType	49
10.8	dateTimeType	49
10.9	dictType	49
10.10	lut16Type	51
10.11	lut8Type	55
10.12	lutAtoBType	57
10.12.1	General	57
10.12.2	“A” curves	58
10.12.3	CLUT	58
10.12.4	“M” curves	59
10.12.5	Matrix	59
10.12.6	“B” curves	59
10.13	lutBtoAType	60
10.13.1	General	60

This is a preview of BS ISO 15076-1:2025. [Click here to purchase the full version from the ANSI store.](#)

10.13.4 “M” curves	61
10.13.5 CLUT	61
10.13.6 “A” curves	62
10.14 measurementType	62
10.15 multiLocalizedUnicodeType	63
10.16 multiProcessElementsType	64
10.16.1 General	64
10.16.2 multiProcessElementsType Elements	65
10.17 namedColor2Type	69
10.18 parametricCurveType	71
10.19 profileSequenceDescType	71
10.20 profileSequenceIdentifierType	72
10.20.1 General	72
10.20.2 Profile ID	73
10.20.3 Profile Description	73
10.21 responseCurveSet16Type	73
10.22 s15Fixed16ArrayType	76
10.23 signatureType	76
10.24 textType	76
10.25 u16Fixed16ArrayType	76
10.26 uInt16ArrayType	77
10.27 uInt32ArrayType	77
10.28 uInt64ArrayType	77
10.29 uInt8ArrayType	78
10.30 viewingConditionsType	78
10.31 XYZType	78
Annex A (informative) Data colour encodings and rendering intents	79
Annex B (informative) Embedding profiles	82
Annex C (informative) Relationship between ICC profiles and PostScript CSAs and CRDs	83
Annex D (informative) Profile connection space	85
Annex E (informative) Chromatic adaptation tag	98
Annex F (normative) Profile computational models	101
Annex G (informative) Tables of required tags and tag list	103
Annex H (informative) Relationship to iccMAX	109
Bibliography	110

This is a preview of BS ISO 15076-1:2025. [Click here to purchase the full version from the ANSI store.](#)

ISO (the International Organization for Standardization) is a worldwide federation of national standards bodies (ISO member bodies). The work of preparing International Standards is normally carried out through ISO technical committees. Each member body interested in a subject for which a technical committee has been established has the right to be represented on that committee. International organizations, governmental and non-governmental, in liaison with ISO, also take part in the work. ISO collaborates closely with the International Electrotechnical Commission (IEC) on all matters of electrotechnical standardization.

The procedures used to develop this document and those intended for its further maintenance are described in the ISO/IEC Directives, Part 1. In particular, the different approval criteria needed for the different types of ISO document should be noted. This document was drafted in accordance with the editorial rules of the ISO/IEC Directives, Part 2 (see www.iso.org/directives).

ISO draws attention to the possibility that the implementation of this document may involve the use of (a) patent(s). ISO takes no position concerning the evidence, validity or applicability of any claimed patent rights in respect thereof. As of the date of publication of this document, ISO had not received notice of (a) patent(s) which may be required to implement this document. However, implementers are cautioned that this may not represent the latest information, which may be obtained from the patent database available at www.iso.org/patents. ISO shall not be held responsible for identifying any or all such patent rights.

Any trade name used in this document is information given for the convenience of users and does not constitute an endorsement.

For an explanation of the voluntary nature of standards, the meaning of ISO specific terms and expressions related to conformity assessment, as well as information about ISO's adherence to the World Trade Organization (WTO) principles in the Technical Barriers to Trade (TBT), see www.iso.org/iso/foreword.html.

This document was prepared by Technical Committee ISO/TC 130, *Graphic technology*.

This third edition cancels and replaces the second edition (ISO 15076-1:2010), which has been technically revised.

The main changes are as follows:

- `cicpTag` has been added to enable HDR metadata to be carried in the profile;
- `metadataTag` and `dictType` have been added to enable flexible definition of additional metadata;
- it has been clarified that `PCSXYZ` values can be negative;
- Tag tables are now required to define a contiguous sequence of unique tag elements, with no gaps;
- `parametricCurveType` functions in [Table 69](#) have been corrected;
- informative [Annex B](#) content on embedding profiles has been replaced with a reference to an ICC Technical Note;
- informative [Annex E](#) on chromatic adaptation has been updated;
- the Bibliography and normative references have been updated.

Profiles created in conformance with this document are identified as Version 4.4.0.0 profiles.

A list of all parts in the ISO 15076 series can be found on the ISO website.

Any feedback or questions on this document should be directed to the user's national standards body. A complete listing of these bodies can be found at www.iso.org/members.html.

This is a preview of BS ISO 15076-1:2025. [Click here to purchase the full version from the ANSI store.](#)

0.1 General

This document specifies the profile format defined by the International Color Consortium® (ICC). The intent of this format is to provide a cross-platform profile format for the creation and interpretation of colour data. Such profiles can be used to translate between different colour encodings, and to transform colour data created using one device into another device's native colour encoding. The acceptance of this format by application and operating system vendors allows end users to transparently move profiles, and images with embedded profiles, between different systems. For example, this allows a printer manufacturer to create a single profile for multiple applications and operating systems.

It is assumed that the reader of this document has a good understanding of colour science and imaging, such as familiarity with CIE, ISO and IEC colour standards, general knowledge of device measurement and characterization, and familiarity with at least one operating system level colour management system.

0.2 International Color Consortium

The International Color Consortium was formed with the primary intent of developing and administering a colour profile format standard, and for the registration of the associated tag signatures and descriptions. The founding members of this consortium can be found on the ICC website¹⁾.

0.2.1 ICC profile versions

The initial version of the profile specification developed by the ICC has undergone various revisions, and it was agreed by the ICC that its revision 4.2 first be proposed as an International Standard. It is that revision which formed the basis of the first edition, ISO 15076-1:2005.^[28] The second edition, ISO 15076-1:2010,^[29] was based on ICC revision 4.3, which is fully backward compatible with 4.2. This document is based on ICC.1:2022 (the ICC revision 4.4 of ICC.1), and is fully backward compatible with earlier versions. All the technical specifications contained in the previous edition (ISO 15076-1:2010) are also given in this document, and new specifications exclusive to this document are identified in the Foreword. Informative material has also been updated and clarified.

The ICC specification is widely used and is referred to in other ISO standards. [Table 1](#) is provided to assist users to identify the main technical differences between versions.

1) Available from <https://color.org/iccmembers.xalter>

ISO 15076-1:2025(en)

This is a preview of BS ISO 15076-1:2025. Click here to purchase the full version from the ANSI store.

ISO version	ICC version	Profile version	Main technical changes relative to previous version
ISO 15076-1:2005	ICC.1:2005	4.2	N/A
ISO 15076-1:2010	ICC.1:2010	4.3	Addition of <ul style="list-style-type: none"> — perceptual intent reference medium colour gamut — new technology signatures — a floating-point device encoding range — a colorimetric intent image state tag — a profile sequence identifier tag Deletion of the mediaBlackPointTag PCSXYZ no longer limited to the PCS illuminant
ISO 15076-1:2024	ICC.1:2024	4.4	Addition of <ul style="list-style-type: none"> — cicpTag to enable HDR metadata to be carried in the profile — metadataTag and dictType added to enable flexible definition of additional metadata Clarified that PCSXYZ values can be negative Tag tables now required to define a contiguous sequence of unique tag elements, with no gaps parametricCurveType functions corrected

The ICC will continue to administer its own version of this document and, if enhancements are made to ICC.1, they will be considered for future revisions of ISO 15076-1. ICC and ISO/TC 130 will work to ensure that there are no significant differences between the ICC and ISO versions of this document.

The ICC web site (www.color.org) provides supplementary information relevant to ISO 15076-1 and ICC.1 and additional resources for developers and users. It also provides information on how to become a member of ICC.

0.3 Colour management architecture and profile connection space

The underlying architecture assumed in this document is based around a reference colour space that is unambiguously defined. The colour specification method selected was that defined by CIE which is internationally accepted. The CIE system enables a set of tristimulus values (CIEXYZ) to be specified for a coloured stimulus. These tristimulus values enable a user to determine whether colours match in appearance when viewed by a typical observer in a specific viewing environment. It follows that it is possible to define the colour appearance of a sample by these tristimulus values (or some defined transformation of them) for a specified state of viewer adaptation. The colour appearance is simply the appearance of the colour to a typical human observer, as opposed to the physical characteristics of the colour stimulus, which is not fully specified using tristimulus values.

Calculation of the CIEXYZ values for transmitting or reflecting media is achieved from the spectral sum-product of the reflectance or transmittance of the sample, the relative spectral power distribution of the illumination source used to view it and the spectral 'sensitivity' of the standard observer. However, as CIE defines two standard observers, two measurement geometries (for reflecting media) and a large number of standard illuminants, it is necessary to restrict these options in order to have a colour specification system that is not ambiguous for a particular application. For this document, the ICC has defined such a restriction, based on ISO 13655, and the resultant colour spaces are known as PCSXYZ and PCSLAB. Furthermore, the simple CIE system (whether CIEXYZ or the CIELAB values derived from them) does not accommodate the effect of surrounding stimuli to the sample being measured (which can be different for various types of media) or the illumination. Both of these affect appearance so the PCS values do not by themselves specify appearance. To overcome this problem, the PCS is used in two different ways. The first accounts only for the assumed state of chromatic adaptation of the viewer, and describes the colorimetry of actual originals and their reproductions, chromatically adapted to the PCS adopted white chromaticity, through the colorimetric

This is a preview of BS ISO 15076-1:2025. [Click here to purchase the full version from the ANSI store.](#)

and optionally for the saturation rendering intent. Thus, it can incorporate corrections for different states of viewer adaptation and other desired rendering effects, as well as accommodating differences between actual colour encoding and device dynamic ranges and colour gamuts, and those of the perceptual intent reference medium. When required, the viewing conditions can be specified to allow colour appearance to be determined for the colorimetric rendering intents.

In summary, the PCS is based on CIEXYZ (or CIELAB) determined for a specific observer (CIE Standard 1931 Colorimetric Observer, often known colloquially as the 2-degree observer), relative to a specific illuminant chromaticity (that of CIE D50), and measured with a specified measurement geometry ($0^\circ:45^\circ$ or $45^\circ:0^\circ$), for reflecting media. Measurement procedures are also defined for transmitting and self-luminous media. Since the conversion from CIEXYZ to CIELAB is quite unambiguous, profile builders can use either colour space for the PCS; the colour management system is able to determine which has been used from a tag in the header.

For colorimetric renderings where the measured data were not obtained relative to a D50 adopted white chromaticity, the profile builder is expected to adapt the data to achieve this. Therefore, a mechanism for identifying the chromatic adaptation used in such situations is provided. For the perceptual rendering intent, the viewing conditions and reference medium are specified in order to provide a clear target for colour rendering and re-rendering (including gamut mapping). In the following paragraphs, the reference colour space, to which reference is made, needs to include the viewing conditions and reference medium when the perceptual intent is being considered. For the perceptual rendering intent, profile builders are expected to undertake any corrections for appearance effects if the viewing conditions used for monitors and transmitting media (such as dark surrounds) differ from those typical for reflecting media, and to account for differences between actual media and the reference medium.

[Figure 1](#) shows how a reference colour space can be used to provide the common interface for transformations between different colour encodings, as used by different devices, or even different operational modes of the same device. Without it, a separate transformation would be required for each pair of device modes. If there are n device modes to be supported in a system, and it is necessary to provide a transformation between each pair of device modes, n^2 transforms would need to be defined and n new transforms would need to be defined every time a new device mode was added. As a new printer device mode can consist simply of a new paper type, this is not a practical solution. By using a reference colour space, only n transforms need be defined and only one new transform needs to be defined each time a new device mode is added; whatever device-to-device transforms are needed can be constructed by linking the source and destination profiles using the reference colour space as the interface.

This is a preview of BS ISO 15076-1:2025. Click [here](#) to purchase the full version from the ANSI store.

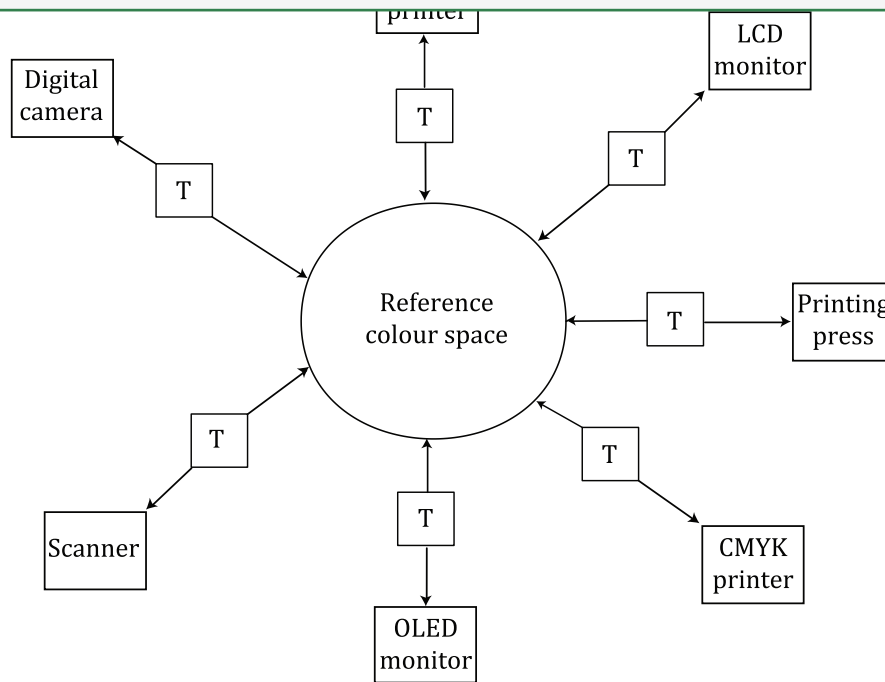

Key

T colour management transform

Figure 1 — Use of a reference colour space

While images can be encoded directly in PCSXYZ or PCSLAB, this will not generally be the case. A number of colour encodings for open exchange have been standardized to meet a variety of needs. Depending on the use case, different bit depths, image states, reference media and colour gamuts are needed. Devices also have different characteristics resulting in different native encodings. Except for a few cases where default encodings for key system devices are used for exchange (like the sRGB encoding), it is not practical or productive to attempt to restrict system colour encoding support.

For reasons of precision, it is usually desirable to define the transformation between the colour data encoding and the profile connection space (PCS) at a high precision. If the transformation between a colour data encoding and the PCS is provided with an image file, it can be utilized when images are reproduced. In order that the transformation between the colour data encoding and the PCS can be interpreted by all applications it is important that it be defined in an open specification. The profile format defined in this document provides that specification.

0.4 Rendering intents

In general, actual device colour gamuts will fail to match each other, and that of the perceptual intent reference medium, to varying degrees. Because of this mismatch, and because of the needs of different applications, four rendering intents (colour rendering styles) are defined in this document. Each one represents a different colour reproduction objective. The colorimetric rendering intents operate directly on measured colorimetric values, with correction for chromatic adaptation when the measured values were not obtained relative to the PCS adopted white chromaticity. The other rendering intents (perceptual and saturation) operate on colorimetric values which are adjusted in an as-needed fashion to account for any differences between devices, media, and viewing conditions.

Two colorimetric rendering intents are specified in this document, though only one is included fully constructed in the profile. The included media relative colorimetric intent is based on media-relative colorimetry, which is normalized relative to the media white for reflecting, transmitting, and self-luminous media, or, in the case of colour encodings and capture, to the colour encoding values that correspond to the highest perceived brightness. Thus, the media white will have the values of 100, 0, 0 in PCSLAB. This ensures that highlight clipping will not occur when the media-relative colorimetric intent is used. The use

This is a preview of BS ISO 15076-1:2025. [Click here to purchase the full version from the ANSI store.](#)

this rendering intent introduces some change in all colours in the reproduction when the media whites of the source and destination do not match.

The PCS adopted white is defined to be the radiance of a perfect reflecting diffuser illuminated by a source with a spectral power distribution matching that of CIE Illuminant D50. ICC profiles contain the values of the media white, adapted to be relative to the chromaticity of the PCS adopted white. For the ICC-absolute colorimetric rendering intent, all of the colorimetric values are re-calculated to be relative to the tristimulus values of the PCS adopted white. When source and destination viewing conditions are identical and an exact colour match is required for all within-gamut colours (including the source medium colour), it is recommended that the ICC-absolute colorimetric rendering intent is used. This rendering intent can also be useful in other situations.

The colour rendering of the perceptual and saturation rendering intents is vendor specific. The former, which is useful for general reproduction of pictorial images, typically includes tone scale adjustments to map the dynamic range of one medium to that of another, and gamut reshaping and mapping to deal with gamut mismatches. The latter has historically been useful for images which contain objects such as charts or diagrams, and usually involves compromises, such as trading off preservation of hue in order to preserve the vividness of pure colours. As the saturation rendering intent is neither required to contain colorimetric characterization information or to use the perceptual intent reference medium, it is the only option, in proprietary systems, for providing colour rendering and re-rendering transforms to and from custom reference media represented in the PCS. For broader interoperability when using the saturation rendering intent, the perceptual reference medium can be used, and its use indicated.

For perceptual transforms it is necessary, in order to optimize colour rendering, to provide a realistic target for the colour rendering. For this reason, a reference medium and reference viewing condition have been defined which apply only to the perceptual rendering. The reference medium is defined as a hypothetical reflection print on a substrate with a white having a neutral reflectance of 89 %, and a density range of 2,459 3. The reference viewing condition is the P2 condition specified in ISO 3664, i.e. D50 at 500 lx for viewing reflecting media. A neutral surround of 20 % reflectance is assumed. The colour gamut of the reference medium is qualitatively specified as that of a reflection print, and whatever colour gamut is used in the PCS is required to be consistent with the specified dynamic range of the perceptual reference medium. It is recommended that the reference gamut specified in ISO 12640-3 be used as a more explicit target gamut for improved interoperability. It is recommended that profile creators consider this gamut to be the target for perceptual intent colour rendering and re-rendering to the PCS. Likewise, the perceptual intent colour re-rendering from the PCS needs to assume this gamut as the starting gamut for colour re-rendering to the destination medium. However, even when the use of this gamut is indicated, perceptual intent transforms need to be designed to produce the best visual results, and need not conform exactly to this gamut in the PCS.

The choice of a reference medium with a realistic black point for the perceptual intent provides a well-defined aim when colour rendering or re-rendering are required. Inputs with a dynamic range greater than a reflection print (e.g. a slide film image, or the colorimetry of high-range scenes) can have their highlights and shadows smoothly compressed to the range of the reference medium in such a way that these regions can be expanded again without undue loss of detail on output to wide-range media. Likewise, images from original media with limited dynamic range can be colour re-rendered to the expanded dynamic range of the reference medium, in order to produce better quality in subsequent reproductions. Bi-directional transform pairs (e.g. data-to-PCS and PCS-to-data for each rendering intent) in the profiles can be used to undo prior PCS-to-data colour re-rendering so that a differently optimized reproduction can be produced for a different reproduction medium.

Profiles generally offer different transformations for different rendering intents. When the rendering intent is selected the corresponding transformation is selected by the colour management system. The choice of rendering intent is highly dependent upon the intended use. In general, the perceptual rendering intent is most applicable for the colour re-rendering of natural images, to make pleasing and aesthetically similar, but not exactly matching, reproductions on different media. The ICC-absolute colorimetric rendering intent is most appropriate for a proofing environment, where the colour reproduction obtained on one device is simulated on another. The media-relative colorimetric rendering intent is appropriate when mapping of the source medium white to the destination medium white is desired, but a full colour re-rendering is not.

This is a preview of BS ISO 15076-1:2025. Click here to purchase the full version from the ANSI store.

0.5 Colour profiles

Colour profiles provide colour management systems with the information necessary to convert colour data between different colour encodings, including device encodings. This document divides colour devices into three broad classifications, i.e. input devices, display devices and output devices. For each device class, a series of base algorithmic models are described which perform the transformation between colour encodings. [Figures 2](#) and [3](#) show examples of these models, which provide different trade-offs in memory footprint, colour quality and performance results. The matrix tone reproduction curve (TRC) model is explained in detail in [8.3.3](#) and [8.4.3](#), the lutBToAType and lutBToAType in [10.10](#) and [10.11](#), and the multiProcessElementsType in [10.14](#). The necessary parameter data to implement these models is described in the appropriate tag type descriptions in [Clause 10](#). This required data provides the information for the colour management framework default colour management module (CMM) to transform colour information between colour encodings. A representative architecture using these components is illustrated in [Figure 4](#).

NOTE Only the models shown in [Figures 2 d\), e\), f\)](#) and [Figures 3 d\), e\) and f\)](#) can be used if the device space has more than three components/colours.

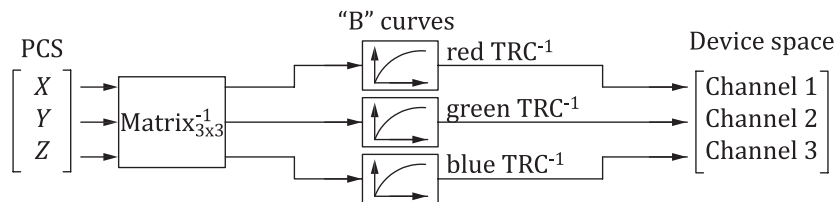

a) Using a matrix/TRC model

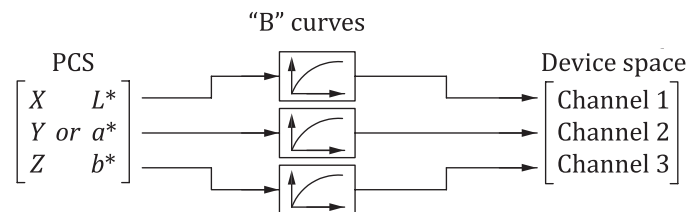

b) Using a lutBToAType model

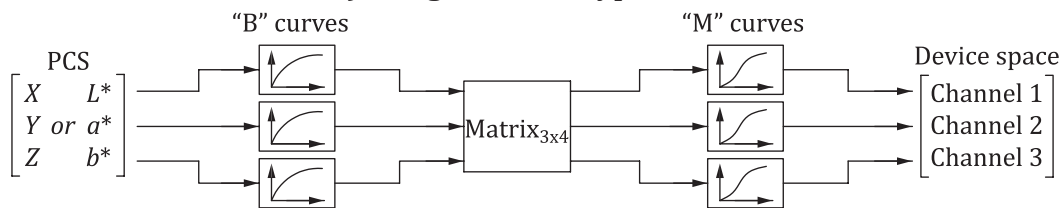

c) Using a lutBToAType model

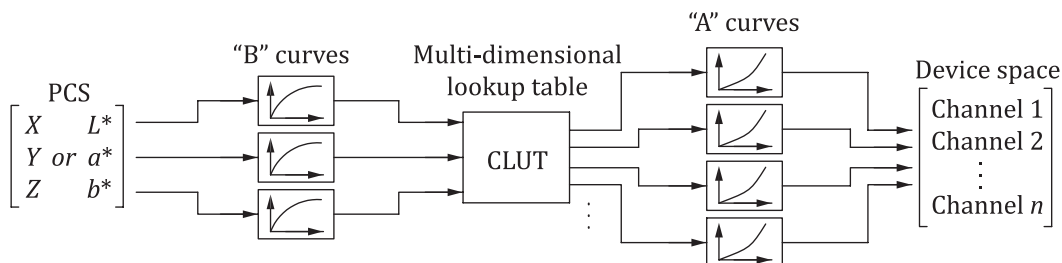

d) Using a lutBToAType model

This is a preview of BS ISO 15076-1:2025. Click here to purchase the full version from the ANSI store.

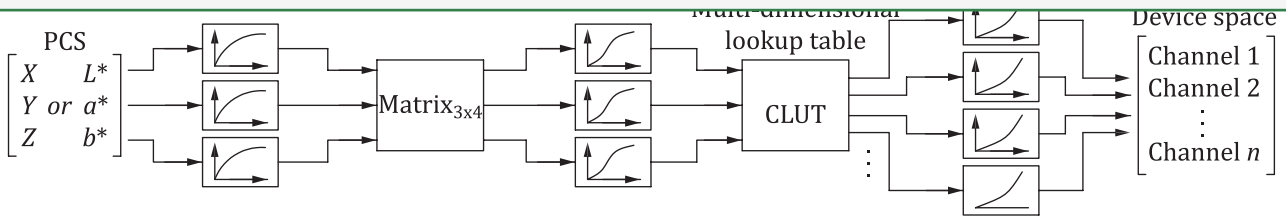

e) Using a lutBToAType model

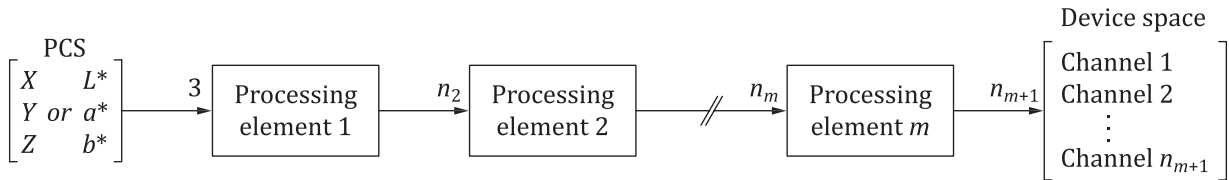

f) Using a multiProcessElementsType tag

Figure 2 — Examples of different ways of converting a colour from PCS to device space

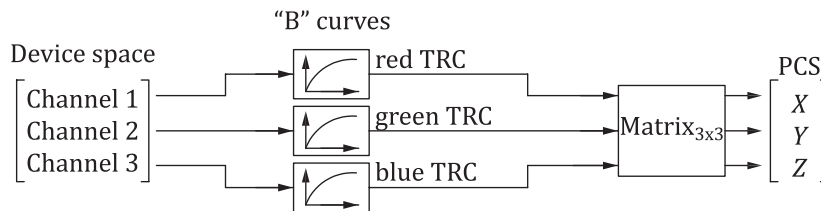

a) Using a matrix/TRC model

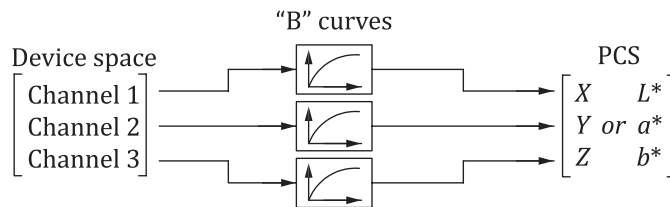

b) Using a lutAToBType model

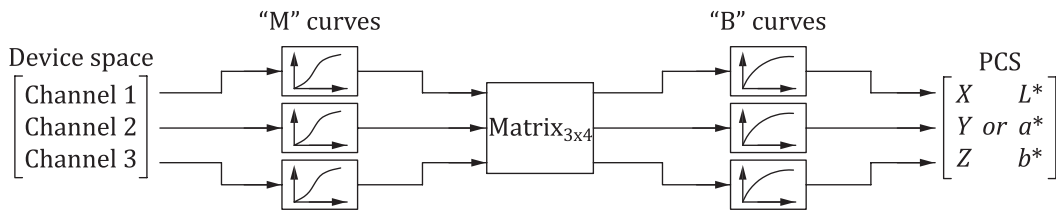

c) Using a lutAToBType model

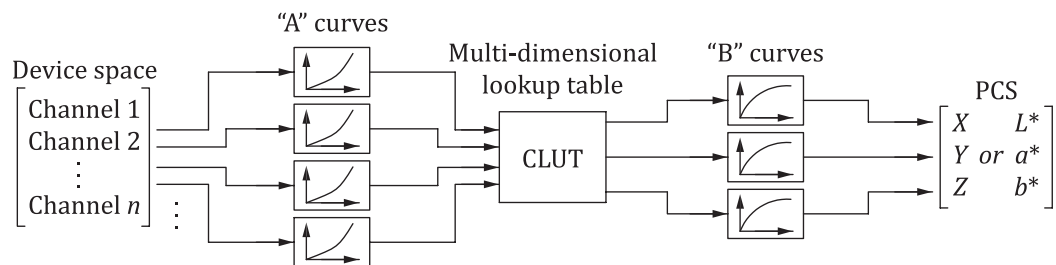

d) Using a lutAToBType model

This is a preview of BS ISO 15076-1:2025. Click here to purchase the full version from the ANSI store.

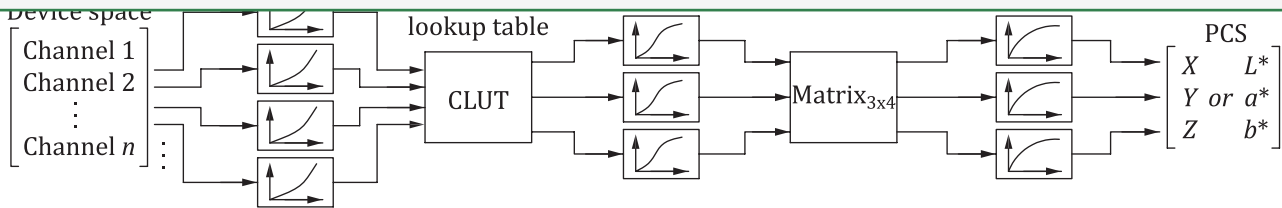

e) Using a lutAToBType model

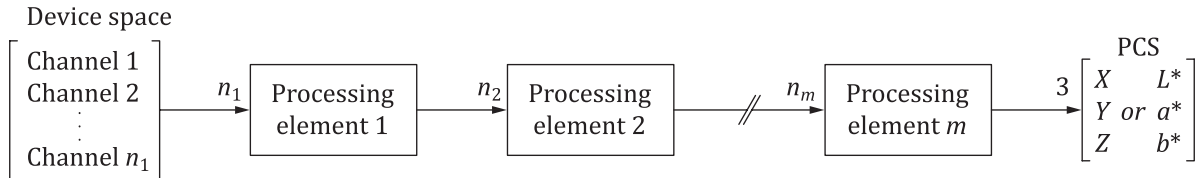

f) Using a multiProcessElementsType tag

Figure 3 — Examples of different ways of converting a colour from device to PCS

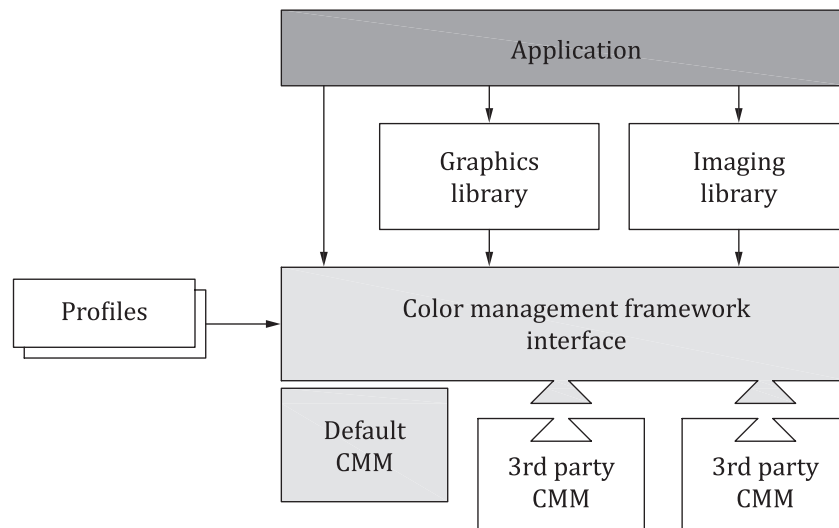

Figure 4 — Colour management architecture

0.6 Profile element structure

The profile structure is defined as a header followed by a tag table followed by a series of tagged elements that can be accessed randomly and individually. This collection of tagged elements provides three levels of information for developers: required data, optional data and private data. An element tag table provides a table of contents for the tagging information in each individual profile. This table includes a tag signature, the beginning address offset and size of the data for each individual tagged element. Signatures in this document are defined as a 4-byte hexadecimal number. This tagging scheme allows developers to read in the element tag table and then randomly access and load into memory only the information necessary to their particular software application. Since some instances of profiles can be quite large, this provides significant savings in performance and memory. The detailed descriptions of the tags, along with their intent, are included later in this document.

The required tags provide the complete set of information necessary for the CMM to translate colour information between the PCS and the data colour encoding. Each profile class determines which combination of tags is required.

This is a preview of BS ISO 15076-1:2025. Click here to purchase the full version from the ANSI store.

description (where appropriate), and intent are registered with the International Color Consortium. Private data tags allow CMM developers to add proprietary value to their profiles. By registering just the tag signature and tag type signature, developers are assured of maintaining their proprietary advantages while maintaining compatibility with this document. However, since the overall philosophy of this format is to maintain an open, cross-platform standard, developers are encouraged to keep the use of private tags to an absolute minimum.

0.7 Embedded profiles

In addition to providing a cross-platform standard for the colour profile format, this document also describes the convention for embedding these profiles within graphics documents and images. Embedded profiles allow users to transparently move colour data between different computers, networks and even operating systems without having to worry if the necessary profiles are present on the destination systems. The intention of embedded profiles is to allow the interpretation of the associated colour data. Embedding profiles is described in ICC Technical Note 10-21 [20].

0.8 Other profiles

Four profile types, in addition to the device profile types described above, are defined in this document. DeviceLink profiles provide a dedicated transformation from one device encoding to another, which can be useful in situations where such a transformation is used frequently or has required optimisation to achieve specific objectives. (Figure 5 shows the various algorithmic models which can be used to construct a DeviceLink profile.)

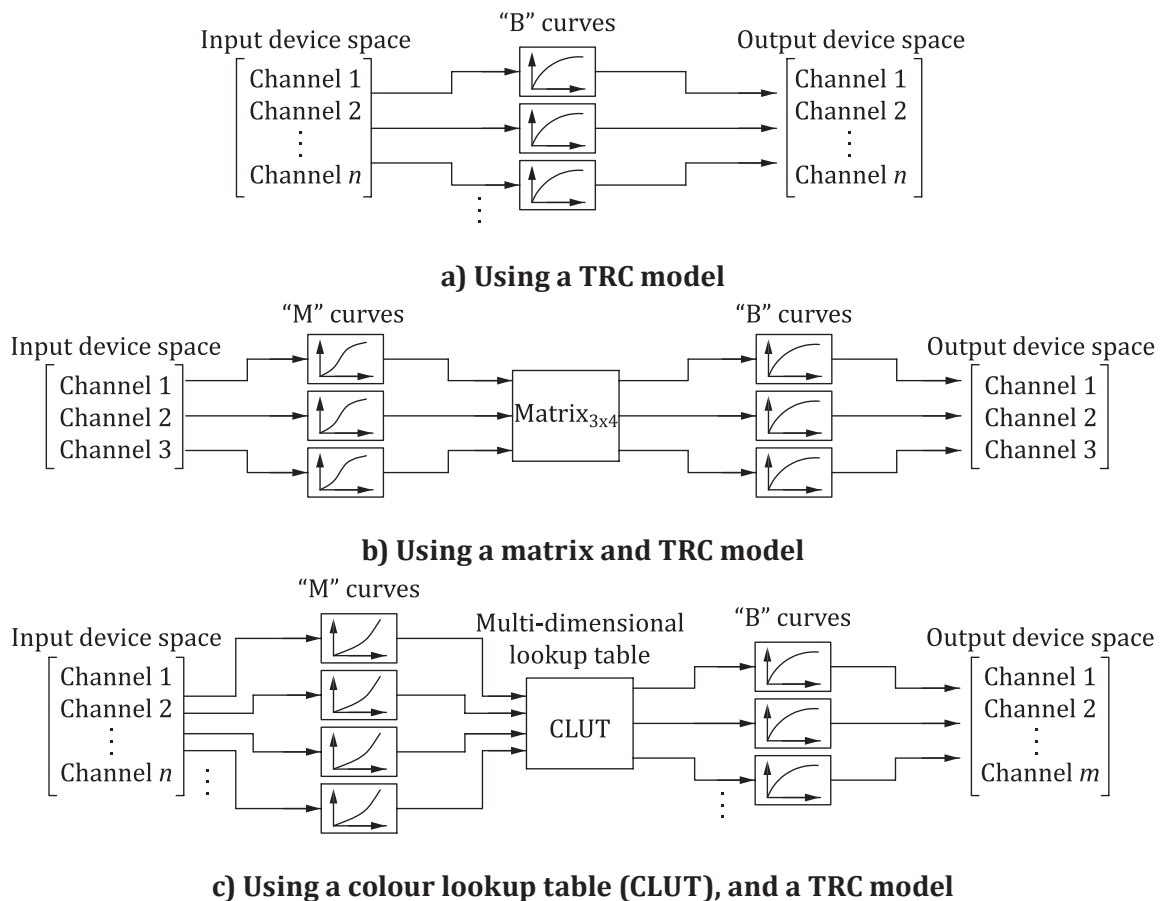

This is a preview of BS ISO 15076-1:2025. Click here to purchase the full version from the ANSI store.

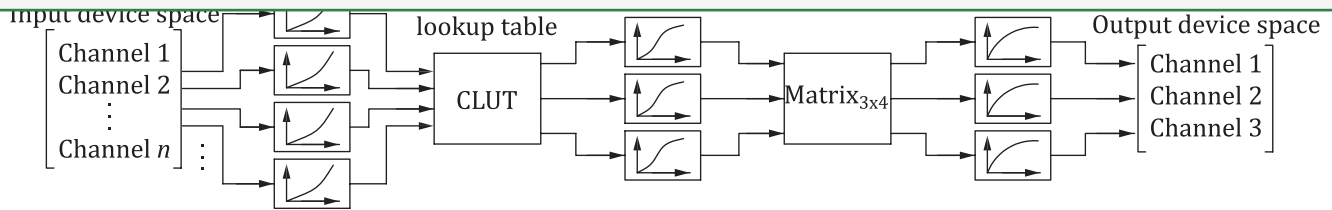

d) Using a CLUT, a matrix, and a TRC model

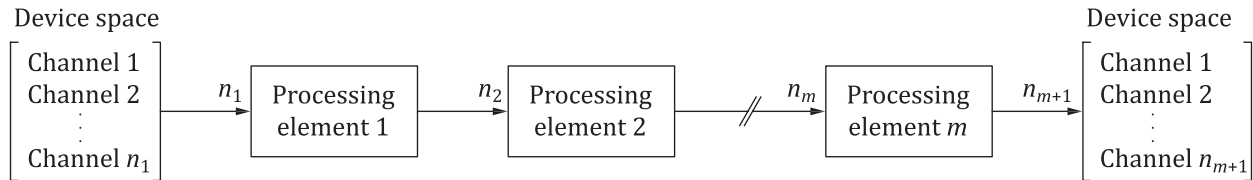

e) Using a multiProcessElementsType tag

Figure 5 — Examples of converting a colour from device to device using a DeviceLink profile

ColorSpace profiles provide transformations between standard colour encodings and the PCS, providing a means for supporting existing and future colour encodings with backward compatibility. Abstract profiles are defined from PCS to PCS and enable colour transformations to be defined that provide some specific colour effects. NamedColor profiles provide a mechanism for specifying the relationship between device values and the PCS for specific colours, rather than for general images.

0.9 Organizational description of this document

This document addresses a very complex set of issues and it has been organized to provide a clear, clean, and unambiguous explanation of the entire format. To accomplish this, the overall presentation is from a top-down perspective, beginning with the summary overview presented above, followed by the necessary background information and definitions needed for unambiguous interpretation of the text. A description of the PCS and rendering intents is then provided before continuing down at increasing levels of detail into a byte stream description of the format. [Clause 6](#) describes the PCS and rendering intents; [Clause 7](#) describes the structure of the various fields required in a profile; and [Clause 8](#) describes the content of the required tags for each profile class. [Clause 9](#) lists the various tags (optional and required) and briefly summarizes the function of the tags as well as listing the signature and permitted tag types for each. The tag types are defined in [Clause 10](#). [Annex A](#) provides additional information pertaining to the data colour encodings and rendering intents used in this document. [Annex C](#) provides a general description of the PostScript Level 2 tags used in this document while [Annex D](#) provides some background material on the PCS. [Annex E](#) provides additional information pertaining to chromatic adaptation and the chromaticAdaptationTag while [Annex F](#) describes some computational models assumed in this document. [Annex G](#) summarizes in tabular form the required tags for each profile class as specified in [Clause 8](#). [Annex H](#) describes the relationship between this document and the ICC.2 specification.

0.9.1 Normalisation and numeric ranges

A convention adopted in the ICC architecture is to normalise data for PCS processing to the range 0 to 1 inclusive. This range is expressed in this document as [0 1].

0.10 Patent information

ISO draws attention to the fact that it is claimed that conformance with this document can involve the use of a patent concerning the outputResponseTag, (support of the outputResponseTag is optional), given in [9.2.36](#). Further information can be obtained from the ICC patent database²⁾.

2) Available from: <https://www.color.org/ip/patents.xalter>

This is a preview of BS ISO 15076-1:2025. [Click here to purchase the full version from the ANSI store.](#)

This is a preview of BS ISO 15076-1:2025. Click here to purchase the full version from the ANSI store.

Image technology colour management — Architecture, profile format and data structure —

Part 1: Based on ICC.1:2022

1 Scope

This document specifies a colour profile format and describes the architecture within which it can operate. This architecture supports the exchange of information which specifies the intended colour image processing of digital data. The required reference colour spaces and the data structures (tags) are also specified.

2 Normative references

The following documents are referred to in the text in such a way that some or all of their content constitutes requirements of this document. For dated references, only the edition cited applies. For undated references, the latest edition of the referenced document (including any amendments) applies.

ISO 5-3, *Photography and graphic technology — Density measurements — Part 3: Spectral conditions*

ISO 639, *Code for individual languages and language groups*

ISO/IEC 646, *Information technology — ISO 7-bit coded character set for information interchange*

ISO 3166-1, *Codes for the representation of names of countries and their subdivisions — Part 1: Country code*

ISO 3664, *Graphic technology and photography — Viewing conditions*

ISO 13655, *Graphic technology — Spectral measurement and colorimetric computation for graphic arts images*

ISO/IEC 23091-2, *Information technology — Coding-independent code points — Part 2: Video*

DIN 16536-2, *Testing of prints and printing inks in graphic technology — Colour density measurements on on-press or off-press prints — Part 2: Instrument specifications for reflection densitometers and their calibration*

EBU Tech. 3213-E, *EBU standard for chromaticity tolerances for studio monitors*

ITU-R BT.709-2, *Parameter values for the HDTV standards for production and international programme exchange*

SMPTE RP145, *SMPTE C Color Monitor Colorimetry*³⁾

INTERNET R.F.C. 1321, *The MD5 Message-Digest Algorithm*, R. Rivest, April 1992, Available from Internet <<ftp://www.ietf.org/rfc/rfc1321.txt>>

IEEE 754, *Standard for Binary Floating-Point Arithmetic*⁴⁾

ICC Tag Registry⁵⁾

3) Available from: <<https://store.smpite.org/category-s/22.htm>>

4) Available from: <<http://ieeexplore.ieee.org>>

5) Available from <https://www.color.org/registry/signature/TagRegistry/>