

# CEMA STANDARD NO. 401-2002

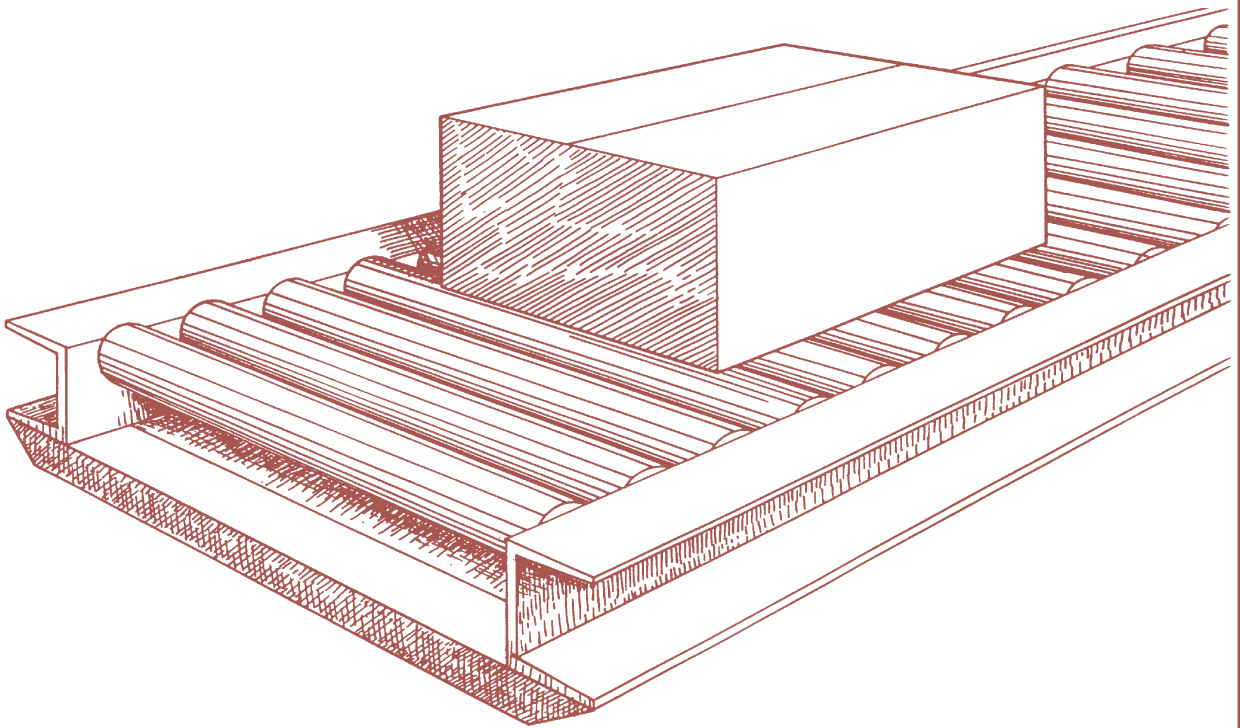

ANSI / CEMA 401-2003  
( Approved September 19, 2003)

## ROLLER CONVEYORS - NON POWERED



## Unit Handling Conveyors



Conveyor Equipment  
Manufacturers Association

ISBN 1-891171-36-4  
PDF Version of  
ISBN 1-891171-05-4

## CEMA ORGANIZATIONAL CHART

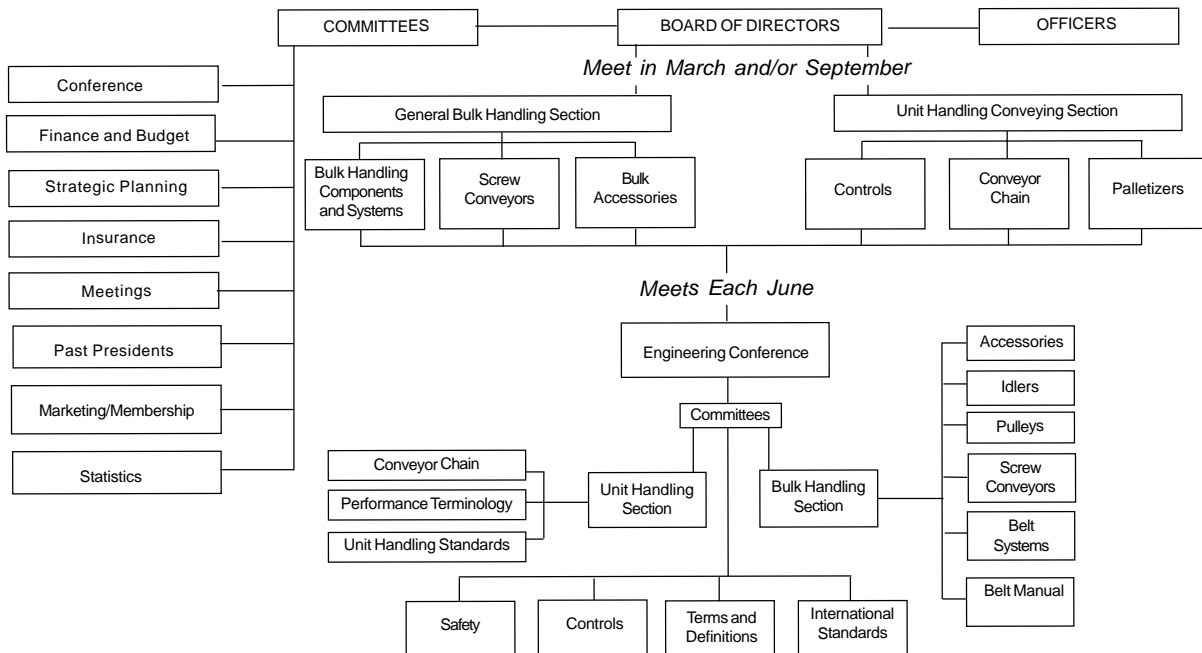

For Information on Company Membership  
visit the CEMA Web Site at  
<http://www.cemanet.org>

### SAFETY NOTICE

The Conveyor Equipment Manufacturers Association has developed Industry Standard Safety Labels for use on the conveying equipment of its member companies.

The purpose of the labels is to identify common and uncommon hazards, conditions, and unsafe practices which can injure, or cause the death of, the unwary or inattentive person who is working at or around conveying equipment.

The labels are available for sale to member companies and non-member companies.

A full description of the labels, their purpose, and guidelines on where to place the labels on typical equipment, has been published in CEMA's *Safety Label Brochure* No. 201. The Brochure is available for purchase by members and non-members of the Association. Safety Labels and Safety Label Placement Guidelines, originally published in the Brochure, are also available free on the CEMA Web Site at [http://www.cemanet.org/CEMA\\_Safety\\_Pg.htm](http://www.cemanet.org/CEMA_Safety_Pg.htm)

**PLEASE NOTE:** Should any of the safety labels supplied by the equipment manufacturer become unreadable for any reason, the equipment USER is then responsible for replacement and location of these safety labels.

Replacement labels and placement guidelines can be obtained by contacting your equipment supplier or CEMA.

### DISCLAIMER

The information provided in this document is advisory only. These recommendations are provided by CEMA in the interest of promoting safety in the work place. These recommendations are general in nature and are not intended as a substitute for a thorough safety program. Users should seek the advise, supervision or consultation of qualified engineers or other safety professionals. Any use of this document, the information contained herein, or any other CEMA publication may only be made with the agreement and understanding that the user and the user's company assume full responsibility for the design, safety, specifications, suitability and adequacy of the system component, or mechanical or electrical device designed or manufactured using this information. The user and the user's company understand and agree that CEMA, its member companies, its officers, agents and employees shall not be liable in any manner under any theory of liability for the user or user's reliance on these recommendations. The users and the user's company agree to release, hold harmless and indemnify CEMA, its member companies, successors, assigns, officers, agents and employees from any and all claims of liability, costs, fees (including attorney's fees), or damages arising in any way out of the use of this information. CEMA and its member companies, successors, assigns, officers, agents and employees make no representations or warranties whatsoever, either express or implied, about the information contained in this document, including, but not limited to, representations or warranties that the information and recommendations contained herein conform to any federal, state or local laws, regulations, guidelines or ordinances.

## FOREWORD

During the past century roller conveyors have developed from the original wooden rollers, with steel pins on the ends rotating in a frame, to the present day all metal construction with anti-friction bearings.

The first attempt to establish a standard method of evaluating the merits of the various sizes and designs being offered in the marketplace was the 1962 edition of CEMA Standard 401.

The purpose of this work is to establish certain minimum standards of comparison for use by concerns which specify, manufacture, and use non-powered roller conveyors.

For additional information relating to definitions and selection of common components, see the latest edition of the following publications: CEMA Standard No. 102, *Conveyor Terms and Definitions*; CEMA Standard No. 402, *Belt Conveyors*; CEMA Standard No. 403, *Belt Driven Live Roller Conveyors*; CEMA Standard No. 404, *Chain Driven Live Roller Conveyors*; CEMA Standard No. 405, *Slat Conveyors*; and CEMA Standard No. 406, *Lineshaft Driven Live Roller Conveyors*.

The illustrations throughout this book are schematic in nature and represent the general nature of a particular device. The illustrations are not intended to represent the recommended safety configurations since guarding has been omitted to permit clarity in showing the operational characteristics of the device. Refer to the current editions of ANSI/ASME B20.1, *Safety Standard for Conveyors and Related Equipment*; ANSI/ASME B15.1, *Safety Standard for Mechanical Power Transmission Apparatus*; and ANSI Z244.1, *American National Safety Standards for Lockout/Tagout of Energy Sources - Minimum Safety Requirements*; Title 29, Code of Federal Regulations (29 C.F.R.) Part 1910.147, *The Control of Hazardous Energy (lockout/tagout)*; Title 29, Code of Federal Regulations (29 C.F.R.) Part 1910 Subpart O, *Machinery and Machine Guarding*. Consult ASME or ANSI for the latest editions.

## TABLE OF CONTENTS

	<i>Section</i>	<i>Page</i>	<i>PDF</i>
DEFINITIONS	1	1	5
APPLICATION DATA	2	3	7
BEARINGS FOR CONVEYOR ROLLERS	3	7	11
TECHNICAL DATA	4	15	19

### CONVEYOR EQUIPMENT MANUFACTURERS ASSOCIATION

6724 Lone Oak Blvd  
Naples, Florida 34109  
Web Site: <http://www.cemanet.org>

Standard No. 401 (PDF) - Copyright 2003  
Printed in the U.S.A.

ISBN 1-891171-36-4  
PDF Version of  
ISBN 1-891171-05-4

## **SUMMARY OF CHANGES IN THIS EDITION**

- All drawings have been cleaned up and enhanced for clarity where necessary.
- Foreword has been updated to include new Safety References.
- A Safety Notice regarding Industry Standard Safety Labels has been added.
- Terms and Definitions have been edited to conform with those in ANSI/CEMA 102 "Conveyor Terms and Definitions".
- All Figures and charts have been redrawn and, in some cases, modified for clarity

**CEMA Standard No. 401-2002  
Reviewed and Revised by  
Unit Handling Section  
of the  
CEMA Engineering Conference**