

CEMA STANDARD NO. 402-2002

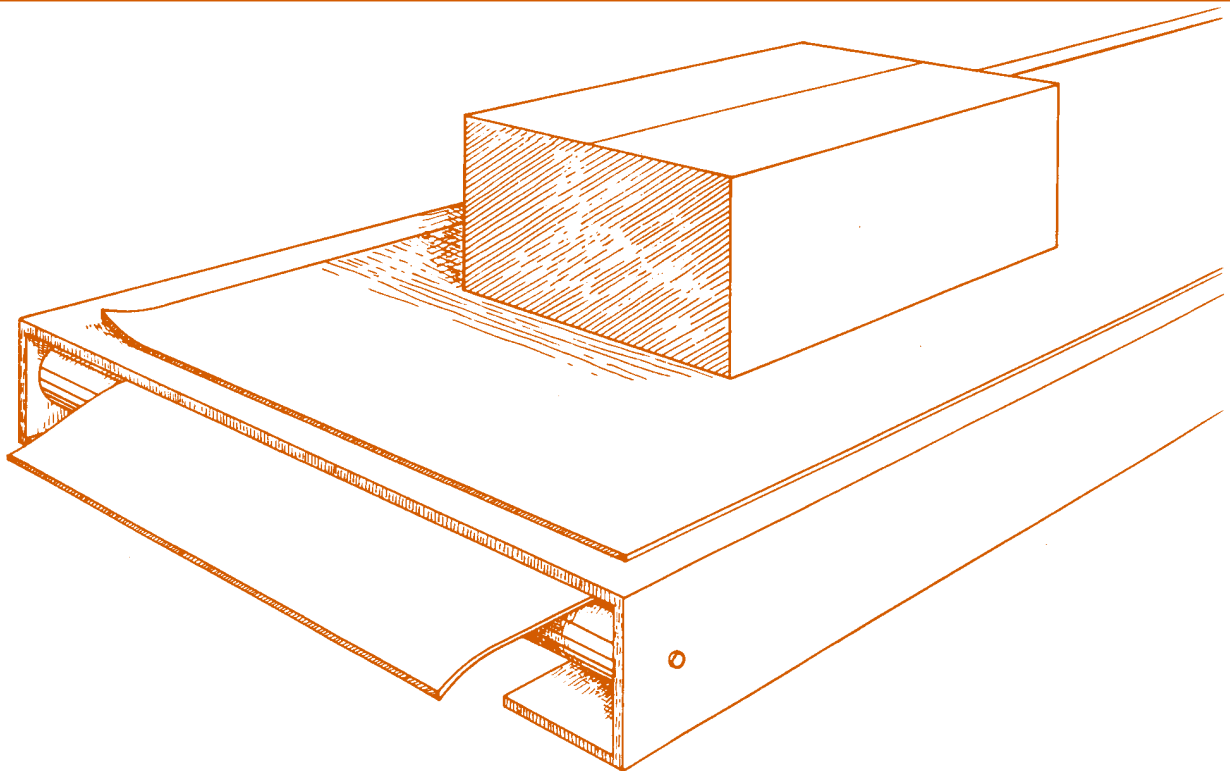

ANSI / CEMA 402-2003
(Approved September 19, 2003)

BELT CONVEYORS



Unit Handling Conveyors



**Conveyor Equipment
Manufacturers Association**

ISBN 1-891171-37-2
PDF Version of
ISBN 1-891171-34-8

CEMA ORGANIZATIONAL CHART

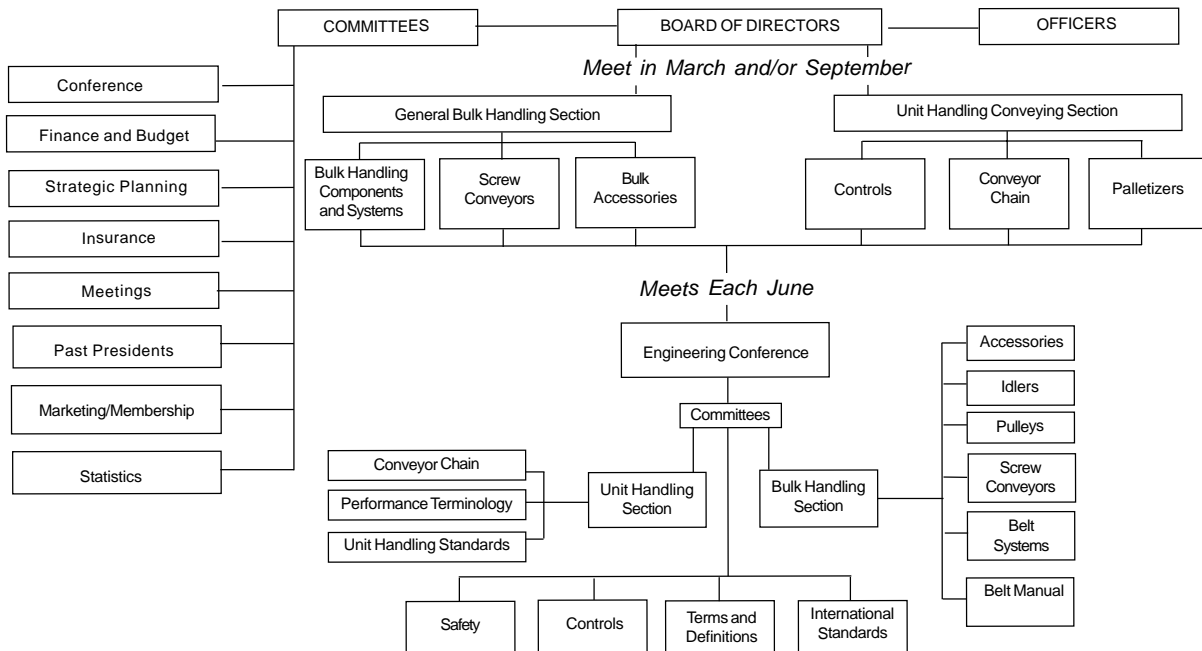

For Information on Company Membership
visit the CEMA Web Site at
<http://www.cemanet.org>

SAFETY NOTICE

The Conveyor Equipment Manufacturers Association has developed Industry Standard Safety Labels for use on the conveying equipment of its member companies.

The purpose of the labels is to identify common and uncommon hazards, conditions, and unsafe practices which can injure, or cause the death of, the unwary or inattentive person who is working at or around conveying equipment.

The labels are available for sale to member companies and non-member companies.

A full description of the labels, their purpose, and guidelines on where to place the labels on typical equipment, has been published in CEMA's *Safety Label Brochure* No. 201. The Brochure is available for purchase by members and non-members of the Association. Safety Labels and Safety Label Placement Guidelines, originally published in the Brochure, are also available free on the CEMA Web Site at http://www.cemanet.org/CEMA_Safety_Pg.htm

PLEASE NOTE: Should any of the safety labels supplied by the equipment manufacturer become unreadable for any reason, the equipment USER is then responsible for replacement and location of these safety labels.

Replacement labels and placement guidelines can be obtained by contacting your equipment supplier or CEMA.

DISCLAIMER

The information provided in this document is advisory only. These recommendations are provided by CEMA in the interest of promoting safety in the work place. These recommendations are general in nature and are not intended as a substitute for a thorough safety program. Users should seek the advise, supervision or consultation of qualified engineers or other safety professionals. Any use of this document, the information contained herein, or any other CEMA publication may only be made with the agreement and understanding that the user and the user's company assume full responsibility for the design, safety, specifications, suitability and adequacy of the system component, or mechanical or electrical device designed or manufactured using this information. The user and the user's company understand and agree that CEMA, its member companies, its officers, agents and employees shall not be liable in any manner under any theory of liability for the user or user's reliance on these recommendations. The users and the user's company agree to release, hold harmless and indemnify CEMA, its member companies, successors, assigns, officers, agents and employees from any and all claims of liability, costs, fees (including attorney's fees), or damages arising in any way out of the use of this information. CEMA and its member companies, successors, assigns, officers, agents and employees make no representations or warranties whatsoever, either express or implied, about the information contained in this document, including, but not limited to, representations or warranties that the information and recommendations contained herein conform to any federal, state or local laws, regulations, guidelines or ordinances.

FOREWORD

Belt conveyors--conveyors which use a belt as a carrying medium--are used for the controlled movement of a great variety of regular or irregular shaped loads, from light and fragile to heavy and rugged unit loads.

The path may be horizontal, inclined or declined, limited only by the stability of the load and the strength of the conveyor components.

Belt conveyors can be operated at the speed best suited for the work being performed. They can be used as a pacesetter for assembly operations, for transportation, or as a timing medium for integrated handling systems.

The purpose of this work is to establish certain minimum standards for use in the design and application of unit handling belt conveyors. For additional information relating to definitions and selection of common components, see current edition of CEMA Standard No. 102, *Conveyor Terms and Definitions* and CEMA Standard No. 401, *Roller Conveyors--Non-Powered*.

The illustrations throughout this book are schematic in nature and represent the general nature of a particular device. The illustrations are not intended to represent the recommended safety configurations since guarding has been omitted to permit clarity in showing the operational characteristics of the device. Refer to the current editions of ANSI/ASME B20.1, *Safety Standard for Conveyors and Related Equipment*; ANSI/ASME B15.1, *Safety Standard for Mechanical Power Transmission Apparatus*; and ANSI Z244.1, *American National Safety Standards for Lockout/Tagout of Energy Sources - Minimum Safety Requirements*; Title 29, Code of Federal Regulations (29 C.F.R.) Part 1910.147, *The Control of Hazardous Energy (lockout/tagout)*; Title 29, Code of Federal Regulations (29 C.F.R.) Part 1910 Subpart O, *Machinery and Machine Guarding*. Consult ASME or ANSI for the latest editions.

Grateful acknowledgment is expressed to the Rubber Manufacturers Association for assistance given in preparation of the section on belting.

TABLE OF CONTENTS

	<i>Section</i>	<i>Page</i>	<i>PDF</i>
DEFINITIONS	1	1	5
APPLICATION	2	11	15
TECHNICAL DATA	3	15	19

CONVEYOR EQUIPMENT MANUFACTURERS ASSOCIATION

6724 Lone Oak Blvd
Naples, Florida 34109

Standard No. 402 - Copyright 2003
Conveyor Equipment Manufacturers Association

Printed in the U.S.A.
ISBN 1-891171-37-2
PDF Version of
ISBN 1-891171-34-8

SUMMARY OF CHANGES IN THIS EDITION

All drawings have been cleaned up and enhanced for clarity where necessary.

Section 1: Definitions

Terms and Definitions have been, expanded, regrouped for ease of understanding, and revised to conform with those in ANSI/CEMA 102 "Conveyor Terms and Definitions". A new section on Pulley Terms and Definitions has been added.

Section 2: Application

Essentially unchanged except for page, table, and figure references.

Section 3: Technical Data

Shaft Calculations have been removed from this standard and replaced with reference to ANSI/CEMA Standard B105.1 "Specifications for Welded Steel Conveyor Pulleys With Compression Type Hubs". This will insure that the standard remains current even if there are changes to B105.1. As a result, the section on shaft size determination and its associated charts have been removed. The previous 15 formulas are now 11.

A "G" term was added to account for an Acceleration Factor in the Roller and Slider Bed formulas. Friction Factors (F_r and F_s) for Roller and Slider Bed formulas have also been added. The formulas have been rewritten to include the Acceleration and Friction Factors.

Four Examples of the application of the data in the Standard are presented to the reader. These examples walk the reader through the entire measurement, analysis, and calculation process.

CEMA Standard No. 402-2002 (PDF)
Reviewed and Revised by
Unit Handling Section
of the
CEMA Engineering Conference