

This is a preview of "DS/EN 12453:2017". [Click here to purchase the full version from the ANSI store.](#)

2017-08-28

Porte til Industri og andre erhverv samt garageporte – Sikkerhed ved brug af automatiske døre og porte – Krav og prøvningsmetoder

Industrial, commercial and garage doors and gates – Safety in use of power operated doors – Requirements and test methods

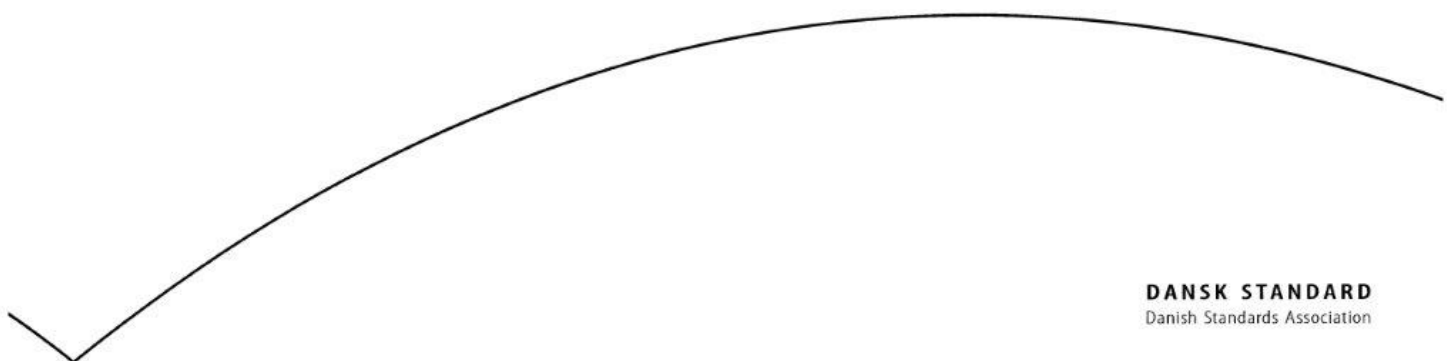

DANSK STANDARD
Danish Standards Association

Göteborg Plads 1
DK-2150 Nordhavn

Tel: +45 39 96 61 01

Fax: +45 39 96 61 02

dansk.standard@ds.dk

www.ds.dk

This is a preview of "DS/EN 12453:2017". [Click here to purchase the full version from the ANSI store.](#)

DS projekt: M265760
ICS: 91.060.50

Første del af denne publikations betegnelse er:

DS/EN, hvilket betyder, at det er en europæisk standard, der har status som dansk standard.

Denne publikations overensstemmelse er:

IDT med: EN 12453:2017.

DS-publikationen er på engelsk.

Denne publikation erstatter: DS/EN 12453:2001, DS/EN 12445:2001.

DS-publikationstyper

Dansk Standard udgiver forskellige publikationstyper. Typen på denne publikation fremgår af forsiden.

Der kan være tale om:

Dansk standard

- standard, der er udarbejdet på nationalt niveau, eller som er baseret på et andet lands nationale standard, eller
- standard, der er udarbejdet på internationalt og/eller europæisk niveau, og som har fået status som dansk standard

DS-information

- publikation, der er udarbejdet på nationalt niveau, og som ikke har opnået status som standard, eller
- publikation, der er udarbejdet på internationalt og/eller europæisk niveau, og som ikke har fået status som standard, fx en teknisk rapport, eller
- europæisk præstandard

DS-håndbog

- samling af standarder, eventuelt suppleret med informativt materiale

DS-hæfte

- publikation med informativt materiale

Til disse publikationstyper kan endvidere udgives

- tillæg og rettelsesblade

DS-publikationsform

Publikationstyperne udgives i forskellig form som henholdsvis

- fuldtekstpublikation (publikationen er trykt i sin helhed)
- godkendelsesblad (publikationen leveres i kopi med et trykt DS-omslag)
- elektronisk (publikationen leveres på et elektronisk medie)

DS-betegnelse

Alle DS-publikationers betegnelse begynder med DS efterfulgt af et eller flere præfikser og et nr., fx **DS 383**, **DS/EN 5414** osv. Hvis der efter nr. er angivet et **A** eller **Cor**, betyder det, enten at det er et **tillæg** eller et **rettelsesblad** til hovedstandard, eller at det er indført i hovedstandard.

DS-betegnelse angives på forsiden.

Overensstemmelse med anden publikation:

Overensstemmelse kan enten være IDT, EQV, NEQ eller MOD

- **IDT:** Når publikationen er identisk med en given publikation.
- **EQV:** Når publikationen teknisk er i overensstemmelse med en given publikation, men præsentationen er ændret.
- **NEQ:** Når publikationen teknisk eller præsentationsmæssigt ikke er i overensstemmelse med en given standard, men udarbejdet på baggrund af denne.
- **MOD:** Når publikationen er modificeret i forhold til en given publikation.

This is a preview of "DS/EN 12453:2017". [Click here to purchase the full version from the ANSI store.](#)

EUROPÄISCHE NORM

August 2017

ICS 91.060.50

Supersedes EN 12445:2000, EN 12453:2000

English Version

Industrial, commercial and garage doors and gates - Safety in use of power operated doors - Requirements and test methods

Portes et portails industriels, commerciaux et
résidentiels - Sécurité d'utilisation des portes et
portails motorisés - Exigences et méthodes d'essai

Tore - Nutzungssicherheit kraftbetätigter Tore -
Anforderungen und Prüfverfahren

This European Standard was approved by CEN on 12 June 2017.

CEN members are bound to comply with the CEN/CENELEC Internal Regulations which stipulate the conditions for giving this European Standard the status of a national standard without any alteration. Up-to-date lists and bibliographical references concerning such national standards may be obtained on application to the CEN-CENELEC Management Centre or to any CEN member.

This European Standard exists in three official versions (English, French, German). A version in any other language made by translation under the responsibility of a CEN member into its own language and notified to the CEN-CENELEC Management Centre has the same status as the official versions.

CEN members are the national standards bodies of Austria, Belgium, Bulgaria, Croatia, Cyprus, Czech Republic, Denmark, Estonia, Finland, Former Yugoslav Republic of Macedonia, France, Germany, Greece, Hungary, Iceland, Ireland, Italy, Latvia, Lithuania, Luxembourg, Malta, Netherlands, Norway, Poland, Portugal, Romania, Serbia, Slovakia, Slovenia, Spain, Sweden, Switzerland, Turkey and United Kingdom.



EUROPEAN COMMITTEE FOR STANDARDIZATION
COMITÉ EUROPÉEN DE NORMALISATION
EUROPÄISCHES KOMITEE FÜR NORMUNG

CEN-CENELEC Management Centre: Avenue Marnix 17, B-1000 Brussels

Contents		Page
European foreword.....		5
Introduction		6
1	Scope	7
2	Normative references	8
3	Terms and definitions	9
4	List of significant hazards	11
4.1	General.....	11
4.2	Hazards caused by crushing, shearing and drawing-in.....	11
4.2.1	General.....	11
4.2.2	Hazards caused when person can travel with the door	12
4.2.3	Hazards caused by impact.....	12
4.3	Hazards caused by source of energy and power controls	12
4.4	Manual operation.....	12
4.5	Other hazards.....	13
4.5.1	General.....	13
4.5.2	Hazards caused by pass doors.....	13
4.5.3	Hazards caused by imprisonment.....	13
4.5.4	Hazards caused by trapping.....	13
4.5.5	Hazards caused by falling or ejected parts or uncontrolled movement	13
4.5.6	Hazards caused by the locking devices	13
4.5.7	Hazards caused due to a loss of stability	13
4.5.8	Hazards caused by glazing material	13
4.5.9	Hazards caused by modification of settings.....	13
5	Safety requirements and/or protective measures	14
5.1	General.....	14
5.1.1	General.....	14
5.1.2	Safety Function performed by control system.....	14
5.1.3	Minimum level of safeguarding at the main closing edge	14
5.2	Crushing, shearing and drawing-in	15
5.2.1	General.....	15
5.2.2	Safeguarding against hazards caused when persons can travel with the door	19
5.2.3	Safeguarding against impact hazard.....	20
5.3	Source of energy and power controls	20
5.3.1	General.....	20
5.3.2	Electrical drive units.....	20
5.3.3	Hydraulic drive units	23
5.3.4	Pneumatic drive units	23
5.3.5	Restart after unintended interruption.....	24
5.3.6	Supply disconnection.....	24
5.4	Manual operation.....	24
5.4.1	General.....	24
5.4.2	Manual operation by direct movement of the door leaf	24
5.4.3	Manual operation directly applied to the drive unit.....	24
5.4.4	Balancing failure at manual operation.....	25
5.4.5	Human physical strength for manual operation of the door leaf	25

This is a preview of "DS/EN 12453:2017". [Click here to purchase the full version from the ANSI store.](#)

5.5	Other hazards.....	25
5.5.1	Pass doors.....	25
5.5.2	Imprisonment	25
5.5.3	Trapping.....	25
5.5.4	Falling or ejected parts or uncontrolled movement	25
5.5.5	Locking devices	26
5.5.6	Loss of stability	26
5.5.7	Glazing material	26
5.5.8	Modification of setting	26
6	Verification of the safety requirements and/or protective measures	26
6.1	General	26
6.2	Crushing, shearing and drawing-in points	27
6.2.1	General	27
6.2.2	Crushing and shearing hazards, caused when persons can travel with the door	28
6.2.3	Impact hazard	29
6.3	Source of energy.....	29
6.3.1	Electrical drive units	29
6.3.2	Hydraulic drive units.....	29
6.3.3	Pneumatic drive units.....	29
6.3.4	Restart after unintended interruption	29
6.3.5	Supply disconnection	29
6.4	Manual operation	30
6.4.1	Manual operation by direct movement of the door leaf.....	30
6.4.2	Manual operation directly applied to the drive unit	30
6.4.3	Balancing failure at manual operation	30
6.4.4	Human physical strength for manual operation of the door leaf.....	30
6.5	Other hazards.....	30
6.5.1	Pass doors.....	30
6.5.2	Imprisonment	30
6.5.3	Trapping.....	31
6.5.4	Falling or ejected parts or uncontrolled movement	31
6.5.5	Locking devices	32
6.5.6	Loss of stability	32
6.5.7	Glazing material	32
6.5.8	Modification of settings	32
7	Information for use	32
7.1	General	32
7.2	Marking	33
	Annex A (normative) Limitation of forces	34
A.1	Specifications	34
A.2	Admissible forces.....	34
	Annex B (informative) Examples of mechanical protection and safety distances	36
B.1	Examples of mechanical protection.....	36
B.2	Examples of appropriate safety clearances and safety distances	37
	Annex C (normative) Force measuring method.....	39
C.1	General	39
C.2	Measuring equipment.....	39

This is a preview of "DS/EN 12453:2017". [Click here to purchase the full version from the ANSI store.](#)

C.3	Points of measuring.....	39
Annex D (normative) Testing method for presence detection		49
D.1	General.....	49
D.2	Test pieces	49
D.3	Testing of supplementary device to be used with force limitation.....	50
D.4	Testing of presence detection system to be used without force limitation	53
Annex E (informative) Safeguarding against dropping by other design features incorporated in the suspension system of vertically moving power operated door leaves.....		57
Annex F (informative) Relationship between Hazards, Requirements and Test clauses		58
Annex ZA (informative) Relationship between this European standard and the Essential Requirements of Directive 2006/42/EC aimed to be covered		60
Bibliography.....		61

This is a preview of "DS/EN 12453:2017". [Click here to purchase the full version from the ANSI store.](#)

European foreword

This document (EN 12453:2017) has been prepared by Technical Committee CEN/TC 33 "Doors, windows, shutters, building hardware and curtain walling", the secretariat of which is held by AFNOR.

This European Standard shall be given the status of a national standard, either by publication of an identical text or by endorsement, at the latest by February 2018, and conflicting national standards shall be withdrawn at the latest by February 2018.

Attention is drawn to the possibility that some of the elements of this document may be the subject of patent rights. CEN shall not be held responsible for identifying any or all such patent rights.

This document will supersede EN 12453:2000 and EN 12445:2000.

This document has been prepared under a mandate given to CEN by the European Commission and the European Free Trade Association, and supports essential requirements of EU Directive(s).

For relationship with EU Directive(s), see informative Annex ZA, which is an integral part of this document.

Compared with EN 12453:2000 and EN 12445:2000, the following changes have been made:

- a) EN 12453 has been revised to be harmonized under Machinery Directive 2006/42/EC;
- b) EN 12453 has been merged with EN 12445; as EN 12445:2000 will be withdrawn;
- c) aligning structure of EN 12453 according to MD templates;
- d) revision of the list of significant hazards (Clause 4);
- e) revision of safety and/or protective measures (Clause 5);
- f) revision of the verification of the safety requirements (Clause 6);
- g) editorial revision of Annex A (limitation of forces);
- h) introducing Annex B (Examples of mechanical protection and safety distances);
- i) introducing Annex C (Force measuring method);
- j) introducing Annex D (Testing method for presence detection);
- k) introducing Annex E (Safeguarding against dropping by other design features incorporated in the suspension system of vertically moving power operated door leaves);
- l) introducing Annex ZA for harmonization of EN 12453 under MD.

According to the CEN-CENELEC Internal Regulations, the national standards organisations of the following countries are bound to implement this European Standard: Austria, Belgium, Bulgaria, Croatia, Cyprus, Czech Republic, Denmark, Estonia, Finland, Former Yugoslav Republic of Macedonia, France, Germany, Greece, Hungary, Iceland, Ireland, Italy, Latvia, Lithuania, Luxembourg, Malta, Netherlands, Norway, Poland, Portugal, Romania, Serbia, Slovakia, Slovenia, Spain, Sweden, Switzerland, Turkey and the United Kingdom.

This is a preview of "DS/EN 12453:2017". [Click here to purchase the full version from the ANSI store.](#)

Introduction

This document is a type C document as stated in EN ISO 12100.

This document is of relevance, in particular, for the following stakeholder groups representing the market players with regard to machinery safety:

- machine manufacturers (small, medium and large enterprises);
- health and safety bodies (regulators, accident prevention organizations, market surveillance etc.)

Others can be affected by the level of machinery safety achieved with the means of the document by the above-mentioned stakeholder groups:

- machine users/employers (small, medium and large enterprises);
- machine users/employees (e.g. trade unions, organizations for people with special needs);
- service providers, e.g. for maintenance (small, medium and large enterprises);
- consumers (in case of machinery intended for use by consumers).

The above-mentioned stakeholder groups have been given the possibility to participate at the drafting process of this document.

The machinery concerned and the extent to which hazards, hazardous situations or hazardous events are covered are indicated in the Scope of this document.

When requirements of this type-C standard are different from those which are stated in type-A or type-B standards, the requirements of this type-C standard take precedence over the requirements of the other standards for machines that have been designed and built according to the requirements of this type-C standard.

This document has been prepared to meet the needs of manufacturers, users and safety enforcement authorities, with the primary purpose of providing design and performance for safety in use of power operated industrial, commercial and garage doors and gates used by vehicular traffic.

Mechanical aspects of the doors are covered by normative references to prEN 12604:2014.

This is a preview of "DS/EN 12453:2017". [Click here to purchase the full version from the ANSI store.](#)

1 Scope

This European Standard specifies requirements and test methods for the safety in use of power operated doors, gates and barriers, intended for installation in areas in the reach of persons, and for which the main intended use is giving safe access for goods and vehicles accompanied or driven by persons in industrial, commercial or residential premises.

This European Standard also covers power operated vertically moving commercial doors such as rolling shutters and rolling grilles, used in retail premises which are mainly provided for goods protection.

This European Standard deals with all significant hazards, hazardous situations and events relevant to the power operation of industrial, commercial and garage doors, and gates when they are used as intended and under conditions of misuse which are reasonably foreseeable as identified in Clause 4.

All lifetime phases of the machinery including transportation, assembly, dismantling, disabling and scrapping are considered by this standard.

This European Standard does not apply to:

- lock gates and dock gates;
- doors on lifts;
- doors on vehicles;
- armoured doors;
- doors mainly for the retention of animals, unless they are at the site perimeter ;
- theatre textile curtains;
- horizontally moving power operated doors mainly intended for pedestrian use;
- doors outside the reach of people (such as crane gantry fences);
- railway barriers;
- barriers intended solely for use by pedestrians;
- barriers used solely for vehicles on motorways.

Whenever the term “door” is used in this document, it shall be deemed to cover the full scope of types and variances of doors, gates and barriers in the scope of this Standard.

This European Standard does not deal with any specific requirements on noise emitted from power operated door, gate and barrier, intended for installation in areas in the reach of persons, and for which the main intended use is giving safe access for goods and vehicles accompanied or driven by persons in industrial, commercial or residential premises as their noise emission is not considered to be a relevant hazard.

NOTE Noise emission of power-operated doors is not a significant hazard for the users of these products. It is a comfort aspect.

This European Standard is not applicable to machinery which are manufactured before the date of publication of the standard.

This is a preview of "DS/EN 12453:2017". [Click here to purchase the full version from the ANSI store.](#)

Z Normative references

The following documents, in whole or in part, are normatively referenced in this document and are indispensable for its application. For dated references, only the edition cited applies. For undated references, the latest edition of the referenced document (including any amendments) applies.

EN 349:1993+A1:2008, *Safety of machinery — Minimum gaps to avoid crushing of parts of the human body*

EN 12433-1:1999, *Industrial, commercial and garage doors and gates - Terminology - Part 1: Types of doors*

EN 12433-2:1999, *Industrial, commercial and garage doors and gates - Terminology - Part 2: Parts of doors*

prEN 12604:2014, *Industrial, commercial and garage doors and gates — Mechanical aspects — Requirements and test methods*

EN 12635:2002+A1:2008, *Industrial, commercial and garage doors and gates — Installation and use*

EN 12978:2003+A1:2009, *Industrial, commercial and garage doors and gates - Safety devices for power operated doors and gates - Requirements and test methods*

EN 60335-1:2012, *Household and similar electrical appliances — Safety — Part 1: General requirements (IEC 60335-1:2012)*

EN 60335-2-95:2015, *Safety of household and similar electrical appliances — Part 2-95: Particular requirements for drives for vertically moving garage doors for residential use (IEC 60335-2-95:2015)*

EN 60335-2-103:2015, *Household and similar electrical appliances — Safety — Part 2-103: Particular requirements for drives for gates, doors and windows (IEC 60335-2-103:2015)*

EN 60529:1991, *Degrees of protection provided by enclosures (IP Code)*

EN 60204-1:2006¹, *Safety of machinery - Electrical equipment of machines - Part 1: General requirements*

EN 61000-6-1:2007, *Electromagnetic compatibility (EMC) - Part 6-1: Generic standards - Immunity for residential, commercial and light-industrial environments*

EN 61000-6-2:2005, *Electromagnetic compatibility (EMC) - Part 6-2: Generic standards - Immunity for industrial environments*

EN 61000-6-3:2007, *Electromagnetic compatibility (EMC) - Part 6-3: Generic standards - Emission standard for residential, commercial and light-industrial environments*

EN 61000-6-4:2007, *Electromagnetic compatibility (EMC) - Part 6-4: Generic standards - Emission standard for industrial environments*

EN 61032:1998, *Protection of persons and equipment by enclosures - Probes for verification*

¹ As impacted by EN 60204-1:2006/A1:2009 and EN 60204-1:2006/AC:2010.

This is a preview of "DS/EN 12453:2017". [Click here to purchase the full version from the ANSI store.](#)

EN ISO 4413:2010, *Hydraulic fluid power - General rules and safety requirements for systems and their components (ISO 4413:2010)*

EN ISO 4414:2010, *Pneumatic fluid power - General rules and safety requirements for systems and their components (ISO 4414:2010)*

EN ISO 12100:2010, *Safety of machinery - General principles for design - Risk assessment and risk reduction (ISO 12100:2010)*

EN ISO 13849-1:2015, *Safety of machinery - Safety-related parts of control systems - Part 1: General principles for design (ISO 13849-1:2015)*

EN ISO 13857:2008, *Safety of machinery - Safety distances to prevent hazard zones being reached by upper and lower limbs (ISO 13857:2008)*

IEC 60417:2002, *Graphical symbols for use on equipment*

ISO 7000:2014, *Graphical symbols for use on equipment — Registered symbols*

3 Terms and definitions

For the purposes of this document, the terms and definitions given in EN ISO 12100:2010, EN 12433-1:1999, EN 12433-2:1999, EN 12978:2003+A1:2009 and the following apply.

3.1

domestic garage door

door used on a domestic garage which is provided for one single household only and where the door does not protrude into a public area

3.2

drive unit

power operated mechanism, including controls, for moving, positioning and retaining the door leaf

Note 1 to entry: Drive units include controls to move the door leaf, except entrapment protection systems.

[SOURCE: EN 12433-2:1999, 6.1]

3.3

drive

motor and other components that control the movement of the driven part

Note 1 to entry: Examples of components are gears, controls, brakes, components for power transmission from the drive to the driven part (e.g. trolleys, rails, levers, etc.) and entrapment protection systems.

Note 2 to entry: The driven part is the part of a gate, door or barrier that is intended to be moved by the drive.

3.4

opening gap

distance between the main closing edge and the opposing closing edge

3.5

non-automatic operated door

door that operates only after intentional activation (hold-to-run control mode or impulse activation) by the user in both directions

3.6
pressure sensitive protective equipment
PSPE

mechanically actuated assembly of devices and/or components working together for protective tripping or presence-sensing purposes comprising as a minimum:

- one or more sensing elements;
- a control unit;
- one or more output signal switching device(s).

Note 1 to entry: Examples are pressure sensitive edges, pressure sensitive floors, pressure sensitive mats and pressure sensitive bars.

[SOURCE: EN 12978:2003+A1:2009, 3.2 modified]

3.7
electro-sensitive protective equipment
ESPE

non-mechanically actuated assembly of devices and/or components working together for protective tripping or presence-sensing purposes comprising as a minimum:

- a sensing function;
- a control / monitoring function;
- one or more output signal switching device(s).

Note 1 to entry: Examples are light beam, capacitive, active infrared, ultra-sonic and image monitoring equipment.

[SOURCE: EN 12978:2003+A1:2009, 3.1 modified]

3.8
safety-related part of a control system
SRP/CS

part of a control system that responds to safety-related input signals and generates safety-related output signals

Note 1 to entry: The combined safety-related parts of a control system start at the point where the safety-related input signals are initiated (including, for example, the actuating cam and the roller of the position switch) and end at the output of the power control elements (including, for example, the main contacts of a contactor).

Note 2 to entry: If monitoring systems are used for diagnostics, they are also considered as SRP/CS.

[SOURCE: EN ISO 13849-1:2015, 3.1.1]

3.9
reversible drive

drive that can be manually operated with or without power in both directions by manual action on the driven part

[SOURCE: EN 60335-2-103:2015, 3.111]

This is a preview of "DS/EN 12453:2017". [Click here to purchase the full version from the ANSI store.](#)

4 List of significant hazards

4.1 General

This Clause contains all the significant hazards, hazardous situations and events identified by risk assessment as significant for this type of machinery and which require action to eliminate or reduce the risk.

NOTE 1 A hazardous point is considered to exist up to a height of 2,5 m above the floor or any other permanent access level.

NOTE 2 As the main function of a door is to open up or close off an opening, the actual movement of the door can produce hazardous situations for persons, goods and vehicles in the vicinity which by nature cannot all be avoided by design.

Annex F is giving the relationship between the hazards listed in this clause, the requirements given in Clause 5 and the test methods described in Clause 6.

The use and the location of the door and the type of door control may influence the severity and probability of risk created by power operated doors.

The severity and probability of risk increases when:

- general public, or infirm, or elderly, or children might come in contact with the moving door;
- there is no possibility to instruct, train or supervise the door users;
- access is not restricted to persons who are the only ones allowed to operate the door (authorized persons);
- a high number of persons may come in contact with the door;
- degree of automation is high;
- door opens directly onto public access areas.

Conversely, non-automatic operated domestic garage doors used for one household only and which do not protrude onto a public access area are considered as doors with a reduced severity and probability of risk.

4.2 Hazards caused by crushing, shearing and drawing-in

4.2.1 General

A hazard exists:

- between the main closing edge of any door and an opposing edge, and between secondary closing edges of hinged, folding, tilting and sliding doors and opposing edges;
- between closing edges and obstacles within the closing area of the leaf;
- between leaves passing each other;
- between leaves and the perimeter of openings in leaves and fixed parts in the vicinity;
- at parts of the leaf which protrude;
- at moving parts of the drive or drive unit which are capable of causing injury;

This is a preview of "DS/EN 12453:2017". [Click here to purchase the full version from the ANSI store.](#)

- at gaps other than main closing gaps which vary in size and are accessible during the leaf movement.

The hazard can be present during the initial impact, the period after the impact and persist because a person can be held between the leaf and the surrounding fixed parts.

4.2.2 Hazards caused when person can travel with the door

If a person can travel with a power operated door, this can lead to foreseeable misuse which can create a hazardous situation.

A person can travel on a door where a finger, hand or foot can gain hold on a door.

If vertically moving doors which can lift a person can lead to a dangerous situation, then a danger point is considered to exist in the following locations:

- between leaves and fixed parts in the vicinity;
- in the neighbourhood of shafts or rising spindles of rolling doors.

4.2.3 Hazards caused by impact

Impact between the moving door and a person can be dangerous because of the impact force from the door leaf.

4.3 Hazards caused by source of energy and power controls

The source of energy used by the drive or drive unit for power operation can create hazards such as:

- electric shock;
- fire from overheating;
- bursting, due to hydraulic or pneumatic over pressure;
- failure of electrical, pneumatic and hydraulic equipment, including safety devices such as protective equipment, entrapment protection systems and control systems;
- unsafe restart after unintended power supply interruption.

4.4 Manual operation

When a power operated door shall be moved manually (e.g. in case of power supply failure), hazardous situations can exist when:

- power operation can occur during manual operation;
- the manual operation handle or device is not properly shaped and/or located;
- the necessary manual effort is not related to the capability of the human body;
- kick-back can occur as a consequence of manual release operation.

This is a preview of "DS/EN 12453:2017". [Click here to purchase the full version from the ANSI store.](#)

4.5 Other hazards

4.5.1 General

In addition to the hazards described above, the following hazards which can occur due to particular site requirements are likely to create dangerous situations.

4.5.2 Hazards caused by pass doors

When a pass door is fitted in the door leaf, the power operation of the door leaf whilst the pass door is not in the safe position can lead to a hazardous situation.

4.5.3 Hazards caused by imprisonment

The hazard of being held imprisoned in areas between power operated doors or in rooms where a power operated door is the only means of escape, can exist.

4.5.4 Hazards caused by trapping

The hazard of being trapped by the door can exist between the moving leaf and fixed parts such that part of the body is held by the door preventing release.

4.5.5 Hazards caused by falling or ejected parts or uncontrolled movement

Hazards can exist if door leaves move in an uncontrolled or dangerous manner.

Hazards can exist if parts of a door are ejected during the movement.

When the door leaf of a power operated door can overrun its final positions, the leaf may then fall down, thus creating a dangerous situation.

4.5.6 Hazards caused by the locking devices

Operation of the drive or drive unit before unlocking the locking device can result in a hazardous situation, e.g. mechanical damage, derailment.

4.5.7 Hazards caused due to a loss of stability

Hazards can exist if the door and its components, including its fixings for attachment to the building and fixing means of the door-leaf, are damaged or permanently deformed.

Hazards can exist if doors are subject to elastic deformations under operational forces or torques.

4.5.8 Hazards caused by glazing material

Hazards can exist if transparent elements in leaves do not remain secured and if they produce sharp splinters, cutting edges or other dangerous parts in case of breaking.

4.5.9 Hazards caused by modification of settings

Hazards can exist if settings, e.g. for limiting forces, options for fitted protective devices, or connections between protective devices and other parts of the safety control system, can easily be modified

5 Safety requirements and/or protective measures

5.1 General

5.1.1 General

Power operated doors shall comply with the safety requirements and/or protective/risk reduction measures of this clause. In addition, the machine shall be designed according to the principles of EN ISO 12100:2010 for any hazards which are not dealt with by this document.

5.1.2 Safety Function performed by control system

The combined safety-related parts of a control system (SRP/CS) which perform the safety function shall be at least PL "c" with the minimum of category 2 according to EN ISO 13849-1. The safety function shall be checked at the latest at one end position of the door leaf.

The safety-related parts of a control system (SRP/CS), include the processing of the signal:

- from the sensing unit of the sensitive protective equipment to the Output Signal Switching Device (OSSD) including the connection between the sensing unit and the drive unit;
- of travel limiting devices;
- of hold to run devices;
- of anti-drop devices;
- of slack cables detecting devices

Safety related parts of a control system which perform the safety function of electrical equipment in compliance with the relevant requirements of EN 60335-2-95 or EN 60335-2-103 are considered to comply with the requirements of this subclause (5.1.2).

5.1.3 Minimum level of safeguarding at the main closing edge

The type of safeguarding at the main closing edge of a power operated door shall be related to the expected type of use.

Three different types of use are considered:

- Type 1: A limited group of persons are trained to use the door and the door is out of public area;
- Type 2: A limited group of persons are trained to use the door and the door is located in a public area;
- Type 3: Any person is free to use the door and the door is in contact with the general public.

Persons can be considered as "trained" if the employer, the premises supervisor or the premises owner has allowed them to use the door and has advised them how to use the door.

A group of persons can be considered to be "limited" if the group consists of identified employees of a company, identified members of a family, or identified persons sharing a block of flats.

This is a preview of "DS/EN 12453:2017". [Click here to purchase the full version from the ANSI store.](#)

The minimum levels of safeguarding of the main edge related to the way the door is operated and to the type of users, are listed in Table 1 according to the following abbreviations:

- A: Hold-to-run control mode of operation according to 5.2.1.5;
- B: Hold-to-run control mode of operation according to 5.2.1.5 with manual actuator equipped with a key switch or similar;
- C: Limitation of forces according to Annex A, either by force limiting means according to 5.2.1.6 or by sensitive protective equipment according to 5.2.1.7;
- D: supplementary device(s) to reduce the probability of contact of a person or an obstacle with the moving door used in combination with all the means indicated in C-. This device shall fulfil 5.2.1.8.
- E: sensitive protective equipment(s) for detection of presence which is designed and installed in a way that a person cannot be touched by a moving door leaf when tested as described in D.4, such a device shall fulfil 5.2.1.7.

Table 1 — Minimum levels of safeguarding at main edge

Type of door activation	Types of use		
	Trained users (public not likely to be present) Type 1	Trained users (public likely to be present) Type 2	Untrained users Type 3
Hold-to-run control mode of operation	A	B	Not possible
Impulse activation in sight of the door	C or E	C or E	C and D, or E
Impulse activation out of sight of the door	C or E	C and D, or E	C and D, or E
Automatic control	C and D, or E	C and D, or E	C and D, or E

In sight of the door is from a position that allows full, direct and permanent real-time view of the door at activation and during the entire movement.

5.2 Crushing, shearing and drawing-in

5.2.1 General

5.2.1.1 General

Hazards listed in 4.2 shall be avoided by design and construction. When this cannot be achieved they shall be safeguarded up to a height of 2,5 m above the floor or any other permanent access level.

This can be achieved by one or a combination of the following measures:

- creating safety distances (see 5.2.1.2);
- installing guards such as enclosures, covers, enclosing guards, fixed protection leaves (see 5.2.1.3);
- shaping and profiling the leaf surfaces and any protruding parts so as to prevent injury (see 5.2.1.4);
- operating the door in the hold to run control mode (see 5.2.1.5);

This is a preview of "DS/EN 12453:2017". [Click here to purchase the full version from the ANSI store.](#)

- limiting the forces generated by the door leaf when meeting a person or an obstacle (see 5.2.1.6);
- installing Electro-Sensitive Protective Equipment (ESPE) (see 5.2.1.7).

For non-automatic operated domestic garage doors for one household only and which do not protrude onto a public access area it is acceptable to safeguard only the hazard generated by the movement of the main closing edge.

5.2.1.2 Gaps to avoid crushing, shearing and drawing in

Crushing, shearing and drawing-in points shall be avoided by design and construction by achieving safe gaps and distances, which are related to the endangered parts of the human body, in accordance with EN ISO 13857 and EN 349 (see examples in Annex B.2).

When safe gaps and distances are dependent on the installation and the site conditions, the installation instructions shall precisely describe the method of ensuring that the safe gaps and distances are effective after the installation is completed.

5.2.1.3 Guards

Guards such as enclosures, covers, enclosing guards, fixed protective leaves (screens), shall be installed to meet the safety distances to prevent hazard zones being reached by upper and lower limbs as specified in Tables 1 and 5 of EN ISO 13857.

Guards shall be designed and constructed according to EN ISO 14120 with the exception of subclause 5.19, which can be disregarded (see examples in Annex B, Figure B.1).

5.2.1.4 Leaf surfaces and protruding parts

Sharp edges shall be avoided by design and construction of the door.

Edges are considered not to be sharp if they are burr-free and rounded.

Protruding parts of the door leaf which may cause injuries shall be avoided by design and construction e.g. by suitable shape. When this cannot be achieved they shall be safeguarded by coverings.

5.2.1.5 Hold-to-run-control mode of operation

The hold-to-run control mode of operation shall be designed in order to fulfil the following requirements:

- the door leaf shall stop when the manual actuator is released. The overrun distance of the door leaf, after the control has been released, shall be
 - not more than 50 mm for door other than swing type when the opening gap does not exceed 500 mm;
 - not more than 100 mm for swing type door when the opening gap does not exceed 500 mm;
 - not more than 100 mm for any type of door when the opening gap exceeds 500 mm;
 - alternatively the main edge of the door leaf shall be fitted with a deformable zone where the available deformation shall be greater than the overrun distance and the resulting static force shall be lower than 150 N measured with the equipment described in C.2.2;
- the leaf movement shall not be initiated by any controls other than manual actuator of the hold-to-run device. This shall be stated in the instructions;

This is a preview of "DS/EN 12453:2017". [Click here to purchase the full version from the ANSI store.](#)

- it shall only be possible to operate the manual actuators in such a position that allows full, direct and permanent real-time view of the door during the leaf movement and ensures that the person controlling the door is not in a hazardous position;

Video cameras do not give a full, direct and permanent real time view.

- The speed of closing the gap shall not exceed 0,5 m/s;
- Unintended operation of manual actuators shall be prevented.

5.2.1.6 Limitation of forces

5.2.1.6.1 General

Forces exerted by door leaves shall not exceed the values specified in Annex A.

When limitation of forces is achieved through protective equipment (e.g. PSPE), such equipment shall be designed to meet the following requirements:

- the hazardous leaf movement is stopped as long as the sensing element is actuated, or until the direction of movement of the door leaf is reversed;
- protective equipment shall fulfil EN 12978;
- it is acceptable that the sensing element of a Pressure Sensitive Protective Equipment (PSPE) is not active within 30 mm of either end.

Protective equipment which is exposed to outdoor conditions shall be at least IP44 according to EN 60529.

5.2.1.6.2 Crushing points

Crushing points can be safeguarded by limitation of forces.

The reversing function, if provided, can be disregarded as soon as the closing gap is < 50 mm for a vertically moving door and < 25 mm for a horizontally moving door.

5.2.1.6.3 Shearing hazards

Shearing hazards occurring between closing edges can be safeguarded by limitation of forces according to Annex A in addition to:

- either a distance of at least 25 mm between passing edges;
- or the passing edges shall be provided with round edges with radius of at least 2 mm for each edge and the sum of the 2 radii shall be at least 6 mm (e.g. at least 2 mm + 4 mm or 3 mm + 3 mm).

5.2.1.6.4 Drawing-in points

Limitation of forces cannot prevent drawing-in.

5.2.1.7 Electro-Sensitive Protective Equipment (ESPE)

When contact is avoided by using ESPE, these devices shall fulfil the following requirements:

- the hazardous leaf movement is stopped as long as the sensing element is actuated, or until the direction of movement of the door leaf is reversed;
- the adjustment can only be done by using a tool;

This is a preview of "DS/EN 12453:2017". [Click here to purchase the full version from the ANSI store.](#)

- protective equipment shall fulfil EN 12978;
- they shall be assessed by using the test pieces described in Annex D.2.

ESPE that monitor environmental changes (e.g. reflecting the light coming back from the ground) shall not adjust to these changes within less than 30 s.

Protective equipment which is exposed to outdoor conditions shall be at least IP44 according to EN 60529.

5.2.1.8 Supplementary device to reduce the probability of contact

Supplementary device used to reduce the probability of contact with a person or obstacle by detecting presence in the area of movement of the door shall meet the following requirements:

- device shall be either Class II or Class III according to EN 60335-1; and
 - the connections (including cable) between the device and the control unit shall be double insulated; and
- either
- periodic checks at intervals which may not exceed six months shall be specified in the maintenance instructions of the door;
- or
- the failure of the device is detected and operation of the door is stopped or it is switched to hold-to-run mode of operation, at the latest at the next end position of the leaf.

Devices that monitor environmental changes (e.g. reflecting the light coming back from the ground) shall not adjust to these changes within less than 30 s as long as the signal transducer is activated.

Devices which are exposed to outdoor conditions shall be at least IP44 according to EN 60529.

If a supplementary device to reduce the probability of contact is required, and if the distance a between the supplementary device and the opposite edge of the door leaf is equal or greater than 150 mm such a device is needed at both sides of a sliding door and vertically moving non-protruding door (see Figure 1).

When a door is safeguarded using presence detection equipment in addition to force limitation, this equipment shall be assessed by using the test pieces described in Annex D.2.

The test pieces, when located according to Annex D.3 and depending on the door type, shall be detected by the presence detection equipment at the latest when they infringe the hazardous area; this shall make the moving door stop or reverse, and shall prevent a door at standstill from hazardous movement.

This is a preview of "DS/EN 12453:2017". Click here to purchase the full version from the ANSI store.

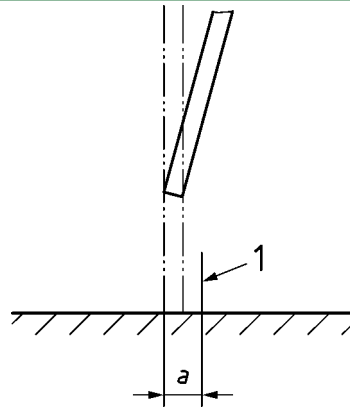

Key

- 1 plane where the supplementary device is active
- a distance between the supplementary device and the opposite edge of the door leaf

Figure 1 — Distance a between door leaf edge and active plane of supplementary device

5.2.2 Safeguarding against hazards caused when persons can travel with the door

When a person can travel with the door (either horizontally or vertically moving), the door movement shall be stopped or reversed protecting any part of a person from possible hazards existing, e.g. at the lintel or other fixed parts of the building or parts of the mechanism of the door. This hazard is considered to exist if the aperture or ledge is located less than 2,5 m above the floor, or any other permanent access level. Protective equipment shall avoid danger by meeting one or a combination of measures specified in 5.2.1.3, 5.2.1.5, 5.2.1.6 and 5.2.1.7.

Apertures are considered to allow persons to travel on the door if test probe B according to EN 61032 can penetrate into the aperture in the door leaf by more than 20 mm deep (measured at horizontal projection to the door).

Additionally for horizontally moving doors:

Ledges are considered to allow persons or objects to travel on the door if:

- the upper surface is less than 18° to the horizontal plane,; and
- the lower surface slopes upwards towards the door at an angle greater than the upper surface; and
- the upper surface does not slope downwards from the adjacent vertical part of the door.

Additionally for vertically moving doors:

- the door shall not be able to lift a mass of 20 kg (or 40 kg for doors intended to be installed in areas out of reach of children), from the closed position;

or

- if the door is able to lift a mass of 20 kg (or 40 kg for doors intended to be installed in areas out of reach of children), the door shall stop before the lifted body reaches the lintel or other fixed parts of the building.

5.2.3 Safeguarding against impact hazard

For doors not operated in the hold-to-run mode, hazards caused by impact with the moving door leaf, as described in 4.2.3, shall be avoided by:

- limiting the forces developed by the door leaf according to 5.2.1.6;

or

- ensuring by electro-sensitive protective equipment, if tested as described in Annex D, or by guards according to 5.2.1.3 that a person cannot be touched by a moving door leaf.

NOTE Guards are usually used to prevent contact with moving parts of the door other than the main edge.

5.3 Source of energy and power controls

5.3.1 General

Hazards, listed in the first four indents of 4.3, shall be avoided by design and construction. When this cannot be achieved they shall be safeguarded as detailed in 5.3.2 or 5.3.3 or 5.3.4 and 5.3.6.

Hazards listed in the fifth indent of 4.3, shall be avoided by design and construction. When this cannot be achieved they shall be safeguarded as detailed in 5.3.5

5.3.2 Electrical drive units

Electrical drive units in compliance with the relevant requirements of EN 60335-2-95 or EN 60335-2-103 are considered to comply with the requirements of this 5.3.2.

The electrical drive units of the power operated door shall comply with EN 60204-1:2006², with the following modifications:

- Clause 4.3.1 Delete the last two indents;
- Clause 4.3.4 is not applicable;
- Clause 4.4.1 Modification: Delete the last sentence of the paragraph;
- Clause 4.4.2 Modification: The clause is replaced by

“Electrical equipment of the power operated door shall not generate electromagnetic disturbances above levels specified in EN 61000-6-4.

Electrical equipment of the power operated door which is intended for installation only in residential, commercial and light-industrial environments shall not generate electromagnetic disturbances above levels specified in EN 61000-6-3.

Electrical equipment of the power operated door shall have a level of immunity to electromagnetic disturbances as specified in EN 61000-6-2.

Electrical equipment of the power operated door which are intended for installation only in residential, commercial and light-industrial environments shall have a level of immunity to electromagnetic disturbances as specified in EN 61000-6-1.

² As impacted by EN 60204-1:2006/A1:2009 and EN 60204-1:2006/AC:2010.

This is a preview of "DS/EN 12453:2017". [Click here to purchase the full version from the ANSI store.](#)

During the immunity tests the electrical equipment of the power operated door shall continue to operate normally or it is switched to hold-to-run mode of operation, at the latest at the next end position of the leaf.”;

- Clause 4.4.3 Modification: The clause is replaced by

“Electrical equipment of the power operated door shall be capable of operating correctly in the intended ambient temperature range as specified by the manufacturer. If not specified, the minimum requirement for electrical equipment of the power operated door shall be ambient temperatures range from +5 °C to +40 °C.”;

- Clause 4.4.6 Modification: Last paragraph is replaced by

“The electrical equipment of the power operated door shall be adequately protected against contaminants (for example dust, acids, corrosive gases, salts, condensation) that can be present in the physical environment in which the electrical equipment of the power operated door is to be installed and be suitable for pollution degree 3.”;

- Clause 4.4.7 Modification: Delete the last sentence of the paragraph;

- Clause 4.4.8 is not applicable;

- Clause 4.5 Modification: Delete the last sentence of the paragraph;

- Clause 5.3 is not applicable;

- Clause 5.4 is not applicable;

- Clause 5.5 is not applicable;

- Clause 5.6 is not applicable;

- Clause 9.2.3 Addition: Add in the end of last paragraph:

“not applicable in cases where an automatic switching to hold-to-run mode of operation, due to a detected fault within a protective equipment, has taken place”;

- Clause 9.2.4 is not applicable

- Clause 9.2.5.1 Addition: Add at the end of the clause:

“During the movement of the drive in either direction, the actuation of a manual control shall stop the movement if there is no separate button for the stop function.

If the drive has a single button for controlling the movement, further actuation shall reverse the direction of movement.

If the drive has three buttons for controlling the movement, one button shall be a stop button.

These requirements do not apply to controls affecting automatic modes of operation.

Any button that has a stop function shall not require a key to stop the drive.

This is a preview of "DS/EN 12453:2017". [Click here to purchase the full version from the ANSI store.](#)

- Clause 9.2.5.2 Modification: The clause is replaced by:

“The start of a hazardous operation, in any other mode than hold-to-run mode of operation, shall be possible only where all of the safeguards are in place and no fault has been detected according to EN 12453:2017, 5.2. Suitable interlocks shall be provided to ensure correct sequential starting”;

- Clause 9.2.5.3 is not applicable;
- Clause 9.2.5.4 is not applicable;
- Clause 9.2.5.5 is not applicable;
- Clause 9.2.6.2 is not applicable;
- Clause 9.2.6.3 is not applicable;
- Clause 9.2.7.1 Addition:

“Add in the end of the clause: Cableless control functions shall not be operational under hold-to-run mode of operation, unless the control is capable of operation only when in direct sight of the door”;

- Clause 9.2.7.3 is not applicable;
- Clause 9.2.7.4 is not applicable;
- Clause 9.2.7.5 is not applicable;
- Clause 9.3.2 is not applicable;
- Clause 9.4.2.2 is not applicable;
- Clause 9.4.2.3 is not applicable;
- Clause 9.4.2.4 is not applicable;
- Clause 10.2.1 is not applicable;
- Clause 10.3.2 is not applicable;
- Clause 10.7 is not applicable;
- Clause 10.8 is not applicable;
- Clause 13.2.1 Modification: Delete the note;

- Clause 14.1 Modification: Replace the subclause by:

“Electrical equipment of the power operated door shall be in compliance with the Clauses 8, 19, 20, 24, 29, 30, 31 of EN 60335-2-103”:

- Clause 14.4 Modification: Add after the first paragraph:

“NOTE Motors may be an integral part of the door construction and might not be easily accessible”;

This is a preview of "DS/EN 12453:2017". [Click here to purchase the full version from the ANSI store.](#)

- Clause 14.6 is not applicable;
- Clause 15.2 is not applicable;
- Clause 16.3 Modification: Replace the clause by:

“Control devices, visual indicators, and displays (particularly those related to safety) shall be clearly and durably marked with regard to their functions either on or adjacent to the item. Symbols given in IEC 60417 and ISO 7000 shall be used”;
- Clause 16.4 Modification: Replace the clause by:

“The marking of the drive unit shall be visibly, legibly and indelibly and shall include the following:

 - name, trade mark or identification mark of the manufacturer or responsible vendor;
 - rated voltage or rated voltage range in volts;
 - symbol for nature of supply, unless the rated frequency is marked;
 - rated power input in watts or rated current in amperes;
 - IP number according to degree of protection against ingress of water of electrical parts;
 - symbol IEC 60417-5172 (2003-02) for class II appliances only;
 - the rated number of operating cycles or the cycles per hour, unless the door is intended for continuous operation.
- Clause 16.5 is not applicable;
- Clause 17 is not applicable;

5.3.3 Hydraulic drive units

Hydraulic drive units shall meet the requirements of EN ISO 4413. Hydraulic drive units shall be equipped with a means to protect them against over pressure.

The drive unit shall be able to resist three times the working pressure.

When a total loss of pressure occurs in the system, the construction shall be such that the door stops or continues to operate at normal speed until it reaches a final end position where the fault is detected and further movement shall be prevented.

The design of the system shall discourage the entrapment of air.

NOTE As air is compressible, any mixture of air with the hydraulic fluid will affect the compressibility of the fluid resulting in a dangerous hydraulic action.

In any case of power interruption, the hydraulic system shall not create any hazardous situation as listed in Clause 4.

5.3.4 Pneumatic drive units

Pneumatic drive units shall meet the requirements of EN ISO 4414. Pneumatic drive units shall be operated at a working pressure $\leq 1,2$ MPa.

This is a preview of "DS/EN 12453:2017". [Click here to purchase the full version from the ANSI store.](#)

Pneumatic drive units shall be equipped with a means to adjust the working pressure, to protect them against over pressure and a means which makes provision for the connection of a measuring gauge.

Pneumatic drive units and pneumatic circuits shall be able to withstand three times the working pressure.

Drive units shall be constructed so that uncontrolled movements because of air compressibility are avoided.

When a total loss of pressure occurs in the system, the construction shall be such that the door stops or continues to operate at normal speed until it reaches a final end position where the fault is detected and further movement shall be prevented

5.3.5 Restart after unintended interruption

Power operated doors shall not restart automatically after the movement has stopped whatever the cause, however automatic doors may restart provided that all safety functions are in place and operational.

5.3.6 Supply disconnection

Means shall be provided to ensure all-pole disconnection from the supply mains. Such means shall be one of the following:

- a supply cord fitted with a plug;
- a switch directly connected to the supply terminals and shall have a contact separation in all poles, providing full disconnection under overvoltage category III conditions according to EN 60664-1;
- an appliance inlet.

5.4 Manual operation

5.4.1 General

If a manual movement of the door leaf (e.g. in case of power supply failure) is possible on a power operated door, it shall be designed so that the manual operation can be carried out without risk.

5.4.2 Manual operation by direct movement of the door leaf

If doors are designed to permit manual operation by direct operation of the leaf, then handles, ledges, hand plates or similar devices shall be provided to enable the leaf to be operated manually.

Such means may be removable. In this case the means shall be provided with the door.

Devices for manual operation positioned on the door leaf shall not be located in the immediate neighbourhood of crushing, shearing and drawing-in points and shall not form crushing and shearing points with fixed or movable parts of the surroundings or of the door, e.g. with walls or counter closing edges.

5.4.3 Manual operation directly applied to the drive unit

The manual and power operated system shall be equipped with a decoupling device so that manual operation is not possible when the door is moving by power operation and vice versa. This requirement does not apply to reversible drives.

Power operation of doors incorporating a reversible drive, or decoupling of a drive shall not have an effect on the door leaf while the door is manually operated.

This is a preview of "DS/EN 12453:2017". [Click here to purchase the full version from the ANSI store.](#)

Means provided for manual operation of the door by operating the drive or to decouple the drive from the door shall be prevented from unexpected movement, such as fly back. They shall be safeguarded against slipping off and unintentional removal.

5.4.4 Balancing failure at manual operation

For vertically moving doors, a failure in the balancing system shall not cause a dangerous movement of the door leaf if the drive is disengaged.

If the failure of the balancing system is secured by an anti-drop device, the drive shall be mechanically or electrically interlocked, or disconnected from power operation, by the anti-drop device if the resulting rated torque or load carried by the drive is bigger than the rated torque or load for which the anti-drop device is rated to resist.

The interlocking or disconnection of the drive shall fulfil PL "C" according to EN ISO 13849-1, but not necessarily meet Category 2.

5.4.5 Human physical strength for manual operation of the door leaf

In case of failure of power operation, and if the door is designed for manual operation, the human physical effort which is needed to operate the door may exceed the values stated in prEN 12604:2014 by not more than 50 %.

5.5 Other hazards

5.5.1 Pass doors

If a pass door is fitted in a power-operated door, movement of the power-operated door shall be prevented when the pass door is not in a safe position, or stop the door movement if the pass door is no longer in a safe position.

Safe position of a pass door is the fully closed position when it travels together with the door, or, when it does not travel with the door, the fully open or complete removed position.

Devices used for such application shall be considered as safety related parts as covered by 5.1.2.

5.5.2 Imprisonment

If the power operated door is the only possible means of exit, it shall be possible to move the door leaf manually from the inside either by decoupling the drive or drive unit from the door leaf or by operation of the drive or drive unit by easily accessible means.

5.5.3 Trapping

Trapping is considered to be covered by the measures required in 5.2.

5.5.4 Falling or ejected parts or uncontrolled movement

Dropping of vertically operating door leaves shall be safeguarded either by an anti-drop device or by other design features incorporated in the suspension system (e.g. slack wire device, force sensing systems). Examples for safeguarding by other design feature are given in the informative Annex E.

Requirements for safeguarding by an anti-drop device are specified in prEN 12604:2014, 4.3.4.

Power operated door leaves shall additionally be safeguarded against dropping in the event of a failure in the door suspension system when the door is switched over from power to manual operation.

When release is provided for manual operation, there shall be means which prevent the leaf from over-travel.

When manual operation is achieved by decoupling the drive from the driven part the requirements of this subclause shall also be met.

This is a preview of "DS/EN 12453:2017". [Click here to purchase the full version from the ANSI store.](#)

An operational brake fitted to the drive is not considered to be an anti-drop safeguard.

Power operated doors shall come to a rest in case of power supply interruption

The requirements specified in prEN 12604:2014, 4.3.1, 4.3.2 and 4.3.5 for safeguarding against dropping of horizontally operating door leaves shall be fulfilled (e.g. by mechanical fixed stops, electrical or electronic travel limiting device, fixed length of mechanical stroke, etc.).

The requirements specified in prEN 12604:2014, 4.7 for parts commonly used in suspension systems shall be fulfilled

The door leaf shall come to a controlled stop at its terminal travel positions.

When electrical or electronic travel limiting devices are used, they shall

- in case of failure maintain their protective function, or
- be used in combination with mechanical fixed stops or
- be used in combination with a secondary travel limiting device, which in case of failure of the primary travel limiting device, is arranged to disconnect the power supply of the drive or drive unit and stop the leaf movement, requiring the door to be manually reset.

When mechanical fixed stops are used, they shall withstand 3,5 times the sum of the maximum force of the drive plus the energy of the moving door leaf at maximum speed.

When relevant, the door leaf shall incorporate means suitable for the declared wind load class of the door to prevent movement due to the influence of wind. These means shall be effective at the relevant terminal position(s).

5.5.5 Locking devices

If a locking device is fitted on a power operated door, activation of the drive or drive unit shall only be allowed when the locking device is unlocked or if the drive unit senses the door is unlocked.

5.5.6 Loss of stability

Requirements for mechanical strength of doors shall meet what is specified in prEN 12604:2014.

Requirements for permitted elastic deformations under operation of doors are defined in prEN 12604:2014.

5.5.7 Glazing material

Requirements for glazing or glazing material are defined in prEN 12604:2014, 5.2.2.

5.5.8 Modification of setting

It shall only be possible to make adjustments that could affect safety related characteristics (e.g. background adjustment, speed of the door, etc.) by means of a tool or by use of a code

6 Verification of the safety requirements and/or protective measures

6.1 General

The requirements specified in Clause 5, shall be verified by the following tests and/or inspections. The tests shall be carried out on a door specimen representative of the door type.

NOTE A door specimen is not necessarily the complete door.

This is a preview of "DS/EN 12453:2017". [Click here to purchase the full version from the ANSI store.](#)

If the door is marked with an ambient temperature range beyond the range of +5 °C to +40 °C, the tests are carried out at the most unfavourable temperature.

Compliance of safety related parts of the control system shall be assessed against EN ISO 13849-1.

6.2 Crushing, shearing and drawing-in points

6.2.1 General

6.2.1.1 General

Test methods for avoiding or safeguarding hazards caused by crushing, shearing and drawing-in points as addressed in 4.2 and to verify the requirements set in 5.2 are the following:

- safety distances, see 6.2.1.2;
- guards such as enclosures, covers, enclosing guards, fixed protection leaves, see 6.2.1.3;
- shaping and profiling the leaf surfaces and any protruding parts so as to prevent injury, see 6.2.1.4;
- operating the door in the hold to run control mode of operation, see 6.2.1.5;
- limiting the forces generated by the door leaf when meeting a person or an obstacle, see 6.2.1.6;
- sensitive protective equipment (ESPE), see 6.2.1.7;
- supplementary device to reduce the probability of contact, see 6.2.1.8;
- crushing and shearing hazards, caused when persons can travel with the door, see 6.2.2;
- impact hazard, see 6.2.3.

6.2.1.2 Safety distances

Safety distances shall be checked by measurement.

6.2.1.3 Guards

Guards shall be checked by inspection and, where necessary to check safety distances, by measurement.

6.2.1.4 Leaf surfaces and protruding parts

Shaping of leaf surfaces and protruding parts shall be checked by visual inspection.

6.2.1.5 Hold-to-run-control mode of operation

“Hold-to-run” control operation shall be checked

- by measurement that, when the manual control device is released, the door leaf stops within the overrun distance specified in 5.2.1.5;
- by inspection of the installation and user instructions;
- by measurement of the speed of the main closing edge. This speed shall be measured at half way of the closing distance.

Manual actuators shall be checked by inspection.

6.2.1.6 Limitation of forces

6.2.1.6.1 General

Forces shall be measured as specified in Annex C.

Additionally, if limitation of forces is achieved by using PSPE, it shall be checked

- by testing, that the control command for stopping the hazardous leaf movement is maintained as long as the protective equipment is actuated, or until a signal for reversing the direction of movement of the door leaf is given;
- by inspection of the documentation that the PSPE complies with the requirements of EN 12978;
- by inspection of the documentation that the PSPE is suitable for the door and drive installed.

6.2.1.6.2 Crushing point

Forces shall be measured as specified in Annex C.

6.2.1.6.3 Shearing point

Forces at shearing points shall be measured as specified in Annex C.

Distances and radii shall be checked by measurement.

6.2.1.7 Electro-Sensitive protective equipment

It shall be checked that the contact to the moving door is avoided by testing according to Annex D.

It shall be checked by inspection that the ESPE is only adjustable by using a tool.

It shall be checked by inspection of the documentation that the ESPE complies with the requirements of EN 12978.

6.2.1.8 Supplementary device to reduce the probability of contact

It shall be checked by inspection and/or testing that the device including the connections to the drive unit complies with 5.2.1.8. Correct functioning of the device shall be tested according to Annex D.

It shall be checked that instructions for use comply with 5.2.1.8.

6.2.2 Crushing and shearing hazards, caused when persons can travel with the door

It shall be checked by measurement whether the aperture or ledge is located at a height less than 2,5 m above the floor, or any other permanent access level.

If located below 2,5 m, it shall be checked whether apertures allow persons to travel on the door according to 5.2.2.

If located below 2,5 m, it shall be checked whether ledges allow persons or objects to travel on the door according to 5.2.2.

For horizontal moving doors, it shall be checked by

- a test body of 120 mm by 120 mm by 500 mm is placed, in the most unfavourable orientation, onto the door leaf where a person could travel with the door and the door is operated to open. The test body shall be detected before reaching a hazardous location and the movement of the door shall be stopped or reversed. The test is repeated closing the door.

This is a preview of "DS/EN 12453:2017". [Click here to purchase the full version from the ANSI store.](#)

Additionally for vertically moving doors:

It shall be checked whether a mass of 20 kg (or 40 kg for doors installed in areas out of public access) attached onto the door leaf, in its most unfavourable position is lifted. The maximum dimension of the mass shall be 200 mm in any direction.

If the mass can be lifted it shall be checked that the door stopped or reversed before the lifted body reaches a hazardous location (e.g. the lintel or other fixed parts of the building) by using the test piece B according to D.2), attached vertically to the door leaf in the most critical position.

The test body is then rotated to expose the other half surface and the test is repeated.

If hazards are safeguarded by hold-to-run mode of operation, test required in 6.2.1.5 need to be complied with.

If hazards are safeguarded by force limitation, tests required in 6.2.1.6 need to be complied with.

If hazards are safeguarded by ESPE, tests required in 6.2.1.7 need to be complied with.

6.2.3 Impact hazard

Impact forces shall be checked by measurement on the main closing edges and at secondary edges, where persons can be pushed, as specified in 6.2.1.6. The measured values shall be less than the maximum values specified in Annex A.

If safeguarding is achieved using ESPE, it shall be checked that the tests as specified in 6.2.1.7 are passed.

6.3 Source of energy

6.3.1 Electrical drive units

It shall be checked by inspection and measurement that electric drive units are in compliance with 5.3.2.

6.3.2 Hydraulic drive units

It shall be checked by inspection and measurement that hydraulic drive units are in compliance with 5.3.3.

6.3.3 Pneumatic drive units

It shall be checked by inspection and measurement that pneumatic drive units are in compliance with 5.3.4.

6.3.4 Restart after unintended interruption

The door is supplied at rated voltage and operated under normal operation. The supply is then interrupted.

After the supply is restored, the door shall not restart automatically. However, automatic doors may restart, provided that they function as in normal use.

The door is operated again and operation of the thermal cut-out is simulated. After the fault condition has been removed, the door shall not restart automatically. However, automatic doors may re-start, provided that they function as in normal use.

6.3.5 Supply disconnection

It shall be checked by inspection that supply disconnection is in compliance with 5.3.6.

6.4 Manual operation

6.4.1 Manual operation by direct movement of the door leaf

Compliance with 5.4.2 shall be checked by visual inspection.

6.4.2 Manual operation directly applied to the drive unit

It is verified by inspection that instructions provided with the door fulfil the requirements of 5.4.3.

It is checked by testing that manual operation of a door, other than one equipped with a reversible drive, is not possible while the door is moving by power operation.

It is checked by testing that power operation of a door, other than one equipped with a reversible drive, cannot start while the door is operated manually.

It is checked by inspection or testing that means provided for manual operation of the door by operating the drive or to decouple the drive from the door are prevented from unexpected movements.

If applicable, it is checked by inspection that the means are safeguarded against slipping off and unintentional removal.

It is checked by testing that power operation does not have an effect on the manual operation of doors incorporating a reversible drive or of doors decoupled from the drive.

6.4.3 Balancing failure at manual operation

It is checked by testing that, in case of failure of the balancing system, disengagement of the drive does not cause a dangerous movement of the door leaf.

When the failure of the balancing system is secured by an anti-drop device it is checked by testing that interlocking or disconnection from power operation of the drive fulfils PL"c" according to EN ISO 13849-1.

It is verified by inspection that information about rated torque of the drive and rated torque or load of the anti-drop device included in instruction provided with the door fulfil the requirements of 5.4.4.

6.4.4 Human physical strength for manual operation of the door leaf

When a manual operation is provided on a power operated door, compliance with 5.4 shall be checked by inspection.

It shall be checked that instructions for use are correctly documented in respect of this point.

The physical effort needed to manually operate the door shall be measured in accordance with prEN 12604:2014.

6.5 Other hazards

6.5.1 Pass doors

It shall be checked that, if a pass door is fitted in a power-operated door, movement of the door is prevented or stopped as long as the pass-door is not in its safe position.

6.5.2 Imprisonment

It shall be checked by testing whether the door can be moved either by decoupling the drive from the door leaf or by actuation of the drive by easily accessible means.

It shall be checked by inspection that the hazard of imprisonment is correctly specified in the installation and user manual.

This is a preview of "DS/EN 12453:2017". [Click here to purchase the full version from the ANSI store.](#)

6.5.3 Trapping

It shall be checked by inspection and/or testing that the requirements of 5.5.3 are fulfilled.

6.5.4 Falling or ejected parts or uncontrolled movement

It shall be checked by inspection that the door leaf stops automatically and safely at its terminal travel positions and that, after a final stop, the door leaf remains in a safe state and does not create any hazard.

Verification of the provisions against disengagement and derailment shall be performed according to prEN 12604:2014, 5.3.1.

Verification of the provisions against uncontrolled movements of vertically operating door leaves shall be performed according to prEN 12604:2014, 5.3.3.

When an Anti-Drop device is provided, verification of effectiveness of these devices shall be performed according to prEN 12604:2014, 5.3.4. Additionally it shall be checked that hazardous movements of the door are not possible after actuation of the anti-drop device.

When means other than anti-drop devices are provided to prevent the door leaf from dropping the following is checked:

- when switching over the door from power operation to manual operation failures of the leaf suspension system are simulated one at a time. The main edge of the door leaf shall not move downwards more than 300 mm even in case of bouncing and any further movement shall not be possible.
- failure of springs of the door leaf balancing system is simulated one at the time. The main edge of the door leaf shall not move downwards more than 300 mm even in case of bouncing and any further movement shall not be possible.
- for doors driven by two drives, failure of one drive at the time is simulated. It shall be checked by visual inspection that the door leaf automatically stops at the latest when it has reached its lower terminal position and that any further movement is not possible.
- for doors driven by hydraulic drives failure of a pipe or supply line are simulated one at the time. The main edge of the door leaf shall not move downwards more than 300 mm even in case of bouncing and any further movement shall not be possible.

It is checked by inspection and/or testing that a drive operational brake is not used as anti-drop safeguard.

The power operation of the door is inhibited and is checked by visual inspection that the door leaf comes to a stop and stays in position.

Provisions against dropping of hinged doors shall be verified according to prEN 12604:2014, 5.3.5. Provisions against disengagement and derailment during operation shall be tested according to prEN 12604:2014, 5.2.1.

Provisions for parts used in suspension and balancing systems shall be verified according to prEN 12604:2014, 5.7.

Unintentional movements due to wind are verified by visual inspection or calculation that means to hold the leaf in position are effective at the relevant terminal position(s) of the door.

When a secondary travel limiting device is used it is checked that in case of failure of the primary travel limiting device the door comes to a safe stop requiring a manual reset to restart operation.

6.5.5 Locking devices

When a locking device is provided, it shall be checked by inspection and testing

- that activation of the drive or drive unit is not possible as long as the locking device remains in its locked position,

or

- that after the drive has sensed the locked door and is deactivated, the lock continues to work properly.

6.5.6 Loss of stability

Requirements specified in 5.5.6 are verified according to prEN 12604:2014, 5.2.1.

6.5.7 Glazing material

It is checked by testing that the door complies with the requirements of 5.5.7.

6.5.8 Modification of settings

It shall be checked by inspection or testing that the requirements of 5.5.8 are fulfilled.

7 Information for use

7.1 General

Information for use shall be provided by the manufacturer in accordance with EN 12635.

Additionally, the information for use shall specify:

- if the door can be used in areas in reach of children (see 5.2.2);
- the location where removable means for manual operation shall be stored, if provided (see 5.4.3). The instructions shall specify that these means are not locked away such that they are not readily accessible;
- that the person operating the means provided for manual operation directly applied to the drive unit cannot be in a hazardous position. They shall also describe how to use the device for manual operation and shall require that the device is permanently stored in the vicinity of the door;
- the safe position of pass doors if fitted;
- any means for decoupling the drive from the door or by actuation of the drive by accessible means to avoid imprisonment;
- that a disconnection means, incorporated in the fixed wiring, to ensure all-pole disconnection from the supply mains is to be provided;
- where and how to correctly install electro-sensitive protective equipment in order to prevent it from being damaged or rendered inoperative during any foreseeable operating conditions;
- that shall electro-sensitive protective equipment be accessible for inspection purposes after installation.

When the door is provided with pneumatic drive units, the information for use shall additionally include:

This is a preview of "DS/EN 12453:2017". [Click here to purchase the full version from the ANSI store.](#)

- a prominent warning shall be given in the instructions of the hazard from uncontrolled movement due to stored energy;
- the instructions shall specify how stored energy can be safely released;
- means for releasing stored energy shall be suitable labelled.

The information for use shall give the A-weighted emission sound pressure level in the vicinity of these products when it is more than 70 dB or, which will generally be the case, shall indicate that this level is less than or equal to 70 dB

7.2 Marking

The marking of the power operated door shall be visibly, legibly and indelibly and shall include the following:

- the business name and full address of the manufacturer and, where applicable, his authorized representative,
- designation of the power operated door,
- designation of series or type,
- serial number, if any,
- the year of construction, that is the year in which the manufacturing process is completed,
- temperature range, if beyond the range +5 °C to +40 °C;
- mandatory marking.

NOTE For machines and their related products intended to be placed on the market in the EEA, the mandatory marking is the CE marking as defined in the applicable European directive(s), e.g Machinery.

The marking of electrical drive units in compliance with the relevant requirements of EN 60335-2-95 or EN 60335-2-103 shall be in accordance with 7.1 of these standards.

The marking of other electrical drive units shall be in accordance with 5.3.2 of this standard.

Annex A (normative)

Limitation of forces

A.1 Specifications

The admissible values in reference to the requirements specified in 5.2.1.6 are according to the following specifications (see Figure A.1):

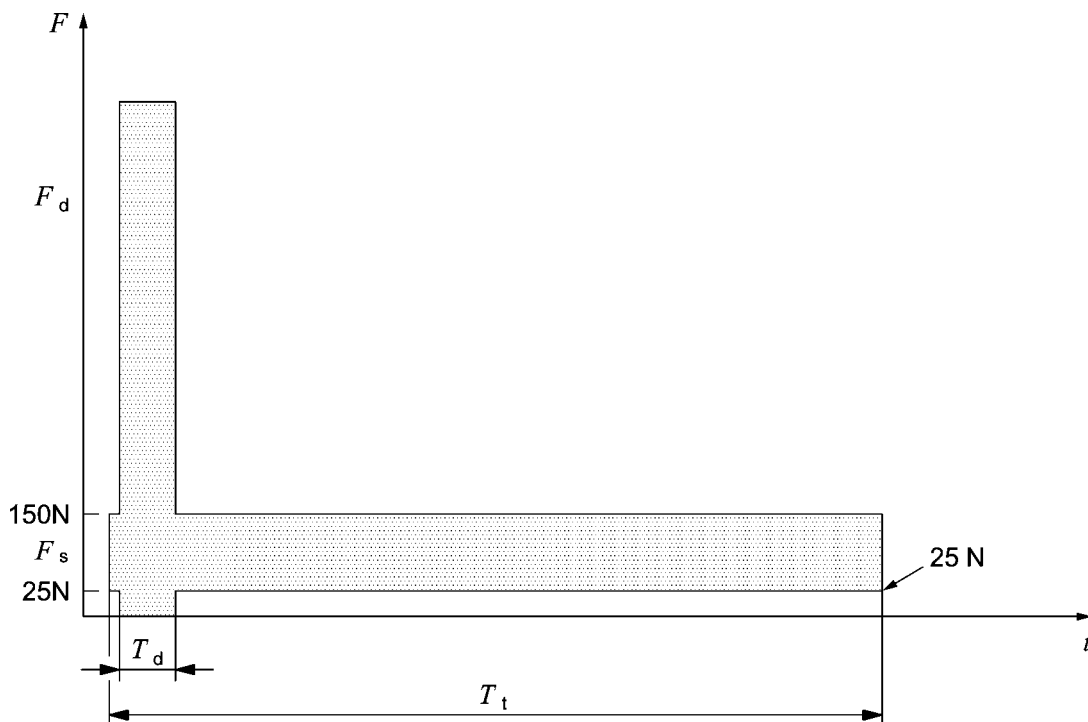

Key

- F_d maximum force measured with the instrument as specified in C.2, during the impact period T_d
- F_s maximum force measured with the instrument as specified in C.2, during the period T_t , forces during T_d not considered
- T_d period of time during which the measured force exceeds 150 N
- T_t period of time during which the measured force exceeds 25 N

Figure A.1 — Force versus time

A.2 Admissible forces

A.2.1 Admissible impact forces

The values of impact force, when force measurements are made at any point using the test method specified in Annex C shall not exceed the values specified in Table A.1.

This is a preview of "DS/EN 12453:2017". Click here to purchase the full version from the ANSI store.

Table A.1 — Admissible impact forces

Admissible impact forces	Between closing edges and counter-closing edges		Between flat areas other than closing edges and counter-closing edges, > 0,1 m ² with no side < 100 mm
	in gaps from 50 mm to 500 mm	in gaps > 500 mm	
horizontally moving door	400 N	1400 N	1 400 N
door rotating around an axis perpendicular to the floor	400 N	1400 N	1 400 N
vertically moving door	400 N	400 N	1 400 N
door rotating around an axis parallel to the floor — barriers	400 N	400 N	1 400 N

The values specified in Table A.1 are maximum values permitted within a period of time of maximum 0,75 s ($T_d \leq 0,75$ s).

A.2.2 Admissible force

After T_d has elapsed, no force > 150 N is allowed. This force shall come down to a residual force < 25 N after a total time T_t of maximum 5 s. The residual force can be achieved either by reversing the movement of the door or by releasing the obstacle.

This limitation of T_t to 5 s can be disregarded under the condition that the force never reaches 50 N provided that the door can be pushed back to a distance of at least 50 mm with a force < 50 N.

However, after T_d , peaks higher than the admissible forces shown in Table A.1 will be accepted, if

— they are decreasing from one to the other

and

— the period of oscillation is ≤ 1 s

and

— the average force calculated within the remaining part of T_t is ≤ 150 N.

Annex B (informative)

Examples of mechanical protection and safety distances

B.1 Examples of mechanical protection

— at sliding doors

Door leaf at the secondary edge is provided with a fixed screen and the secondary edge does not come out from the screen.

The distance between door leaf and building component and between door leaf and screen is not more than 8 mm.

Dimensions in millimetres

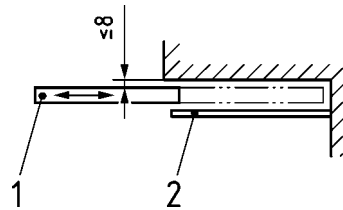

Key

- 1 handle
- 2 screen

Figure B.1 — Guard at a sliding door

— at hinged doors

A deformable sealing is mounted at the secondary edge which allows a safety distance of 25 mm, measured in compressed state with static force not greater than 150 N on a 80 mm diameter test piece

Dimensions in millimetres

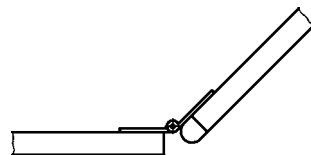

Figure B.2 — Protection at a hinged door

Secondary edge is protected by a profile.

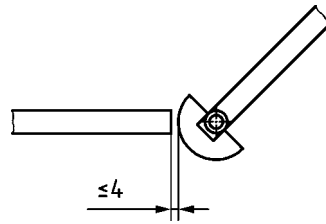

Figure B.3 — Protection profile

B.2 Examples of appropriate safety clearances and safety distances

— at sliding doors

- A clearance of 500 mm is provided at the secondary edge of a leaf moving along, but apart from, a closed wall (See Figure B.4 a)).
- A clearance of 200 mm is provided at the secondary edge of a leaf, moving along a closed wall in distance of less than 100 mm (See Figure B.4 b)).

Dimensions in millimetres

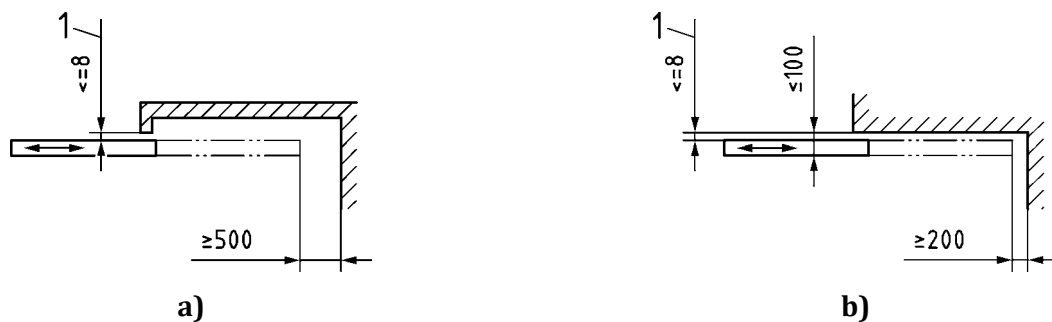

Key

1 gap

Figure B.4 — Safety clearance and distance at sliding doors

- Safety distances between door leaf and fence for sliding doors moving along a fence with apertures, are shown in Table B.1.

Table B.1 — Safety distances in relation to apertures in fences

Aperture in fences [mm] (smaller dimension of a rectangular aperture)	Safety distances mm
$\leq 18,5$	120
$> 18,5 \leq 29$	300
$> 29 \leq 44$	500
$> 44 \leq 100$	850

This is a preview of "DS/EN 12453:2017". [Click here to purchase the full version from the ANSI store.](#)

Annex C (normative)

Force measuring method

C.1 General

When limitation of forces is used to safeguard hazards, forces developed by a power operated door shall be measured with a test equipment with characteristics as specified in C.2.

Dependant on the type of door and door movement, the points where the forces have to be measured and the direction of measurement are specified in C.3.

The measurements shall be performed on a complete door assembly, fully equipped with all safety devices incorporated and adjusted as specified in the instructions of the manufacturer.

C.2 Measuring equipment

C.2.1 General

Technical characteristics of the force measuring equipment are given in C.2.2.

The force measuring equipment shall be regularly calibrated.

C.2.2 Reference measuring equipment

The test equipment for measuring forces shall consist of the following parts:

- two contact areas with a diameter of $80 \text{ mm} \pm 1 \%$. The contact areas shall be made of suitable material and be of sufficient thickness to retain rigidity;
- a spring which gives the contact area a spring ratio of $500 \text{ N/mm} \pm 50 \text{ N/mm}$;
- a load cell with an amplifier and a display unit, or any equivalent mechanical or electromechanical system.

The test equipment used for measurement of forces versus time shall also be equipped with a plotter, XY recorder or similar.

The test equipment shall fulfil the following data:

- measuring range from 25 N to 2 000 N;
- rising/falling time of the load cell amplifier not $> 5 \text{ ms}$.

The accuracy of the equipment shall be $\pm 5 \%$ or $\pm 10 \text{ N}$, whichever is the maximum deviation.

C.3 Points of measuring

C.3.1 General

Three measurements shall be made at each measuring point. The mean average value obtained for each point shall fulfil the requirements. In the following, the points of measuring are specified for different door types, having to take the opening gap and direction of measurement into consideration.

This is a preview of "DS/EN 12453:2017". [Click here to purchase the full version from the ANSI store.](#)

The direction of measurement shall be parallel to the line of application of the spring force of the measuring instrument effected by the leaf during the process of measuring. The line of application shall be synchronised with the centre line of the spring inside the measuring instrument, and shall pass through the centre points of the 80 mm contact areas of the measuring instrument.

For doors with pressure sensitive protective equipment, where the contact area of the measuring instrument comes too close to the extreme end of the edge, it is accepted that the instrument is moved so that:

- the measuring point is still covered by the contact area of the instrument; and
- the distance between the extreme end of the closing edge and the edge of the contact area is 30 mm maximum.

All dimensions specified in the following clauses and figures shall be within $\pm 5\%$ of the specified values.

C.3.2 Sliding door

C.3.2.1 General

On a sliding door, the closing and opening forces shall be measured on both main and secondary closing edges.

The forces shall be measured in the direction parallel to the direction of the movement of the closing edge.

C.3.2.2 Measuring between the main closing edge and the opposing edge, or between two main closing edges

The measurement of forces shall be carried out at points located at different heights (see Figure C.1) as follows:

- at 50 mm above the lower edge of the door;
- in the middle of the main closing edge or when the length of the main closing edge is $> 2\,800$ mm, at a height of 1 500 mm above the floor;
- and 300 mm below the upper edge of the door leaf or where the length of the main closing edge is $> 2\,800$ mm, at a height of 2 500 mm above the floor;

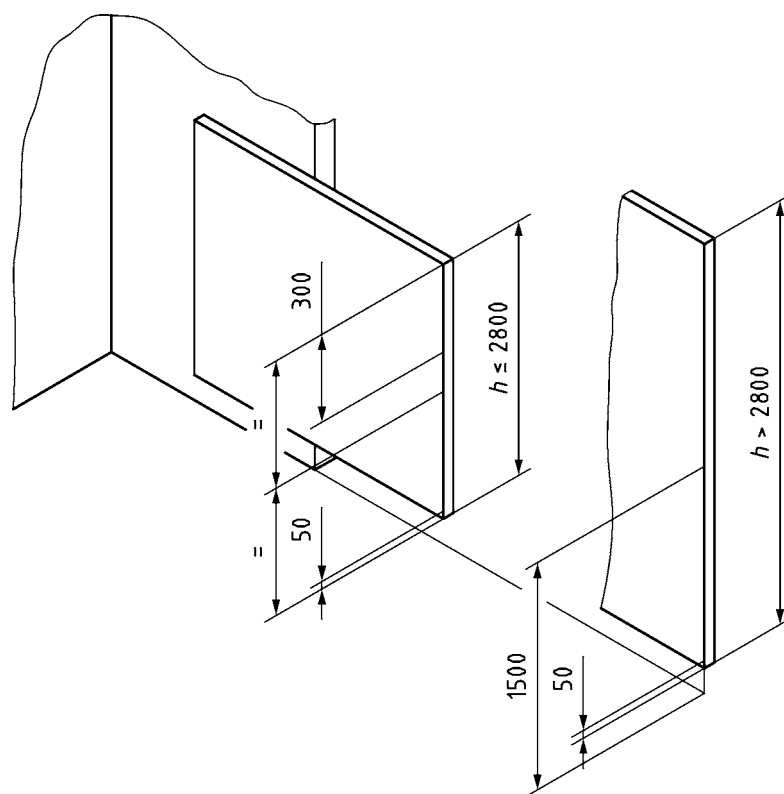

Figure C.1 — Points of measuring at the leaf of a sliding door

and at the two different opening gaps between the main closing edge and the opposing edge (see Figure C.2) of

- 50 mm;
- 500 mm.

An additional measurement is taken at a gap of 1500 mm between the main closing edge and the opposing edge in the middle of the main closing edge.

Dimensions in millimetres

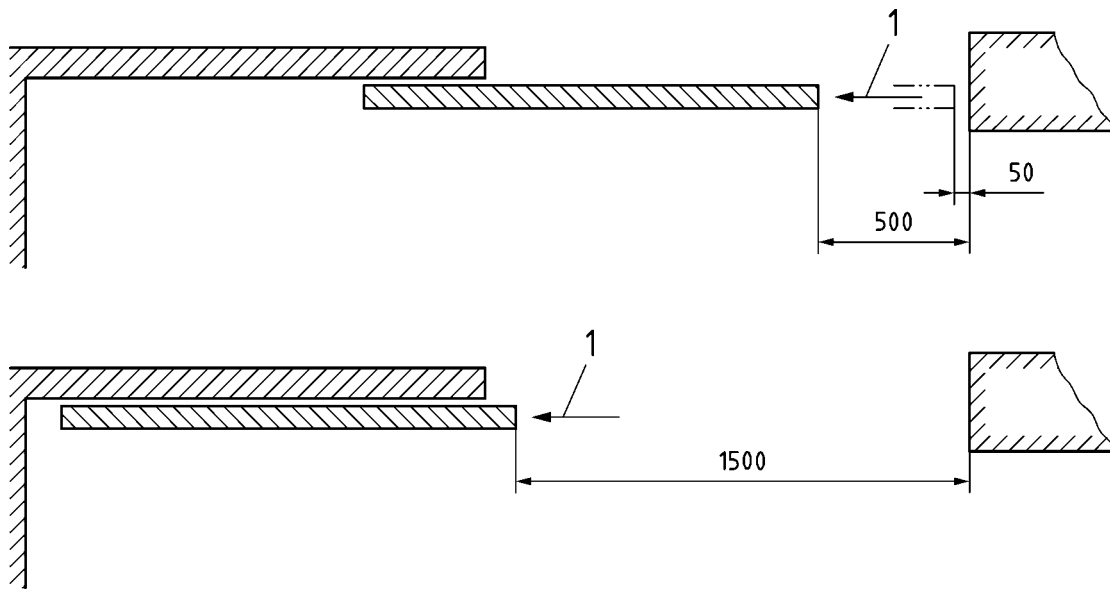
**Key**

1 direction of measuring force

Figure C.2 — Openings gaps between the main closing edge of a sliding door and the opposing edge

C.3.2.3 Measuring between the secondary edge of the leaf and neighbouring hard parts of the surroundings

The measurement of forces shall be carried out between the secondary edge of the leaf and neighbouring stiff parts of the surroundings in a similar manner to the measuring of forces between the main closing edge and the opposing edge according to C.3.2.2.

The gap shall be determined between the most outstanding parts of the secondary edge and the neighbouring parts of the surroundings.

C.3.3 Hinged door

C.3.3.1 General

On a hinged door, the closing and opening forces shall be measured between the main and opposing edge and between the door leaf and any hard part of the surrounding.

C.3.3.2 Measuring between the main closing edge and the opposing closing edge, or between two main closing edges

On hinged doors, measurement of forces shall be carried out at points situated at three different heights (see Figure C.3):

- 50 mm above the lower edge of the door;
- in the middle of the height of the door leaf or when the height of the door leaf is > 2 800 mm, at a height of 1 500 mm above the floor;
- 300 mm below the upper edge of the door leaf or when the height of the door leaf is > 2 800 mm, at a height of 2 500 mm above the floor;

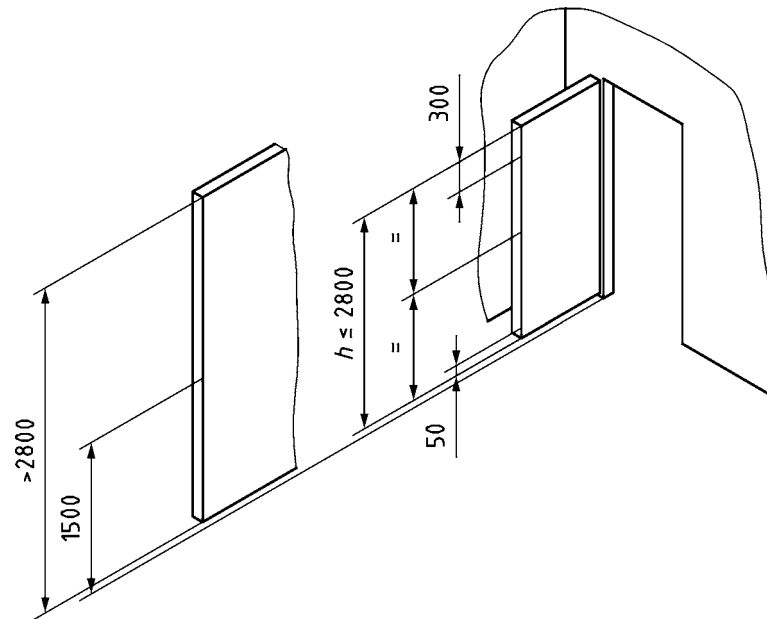

Figure C.3 — Points of measuring at the leaf of a hinged door

and at the following three opening gaps between the door leaf and the opposing edge turned towards the leaf (see Figure C.4):

- 50 mm;
- 500 mm;
- 1 500 mm.

Dimensions in millimetres

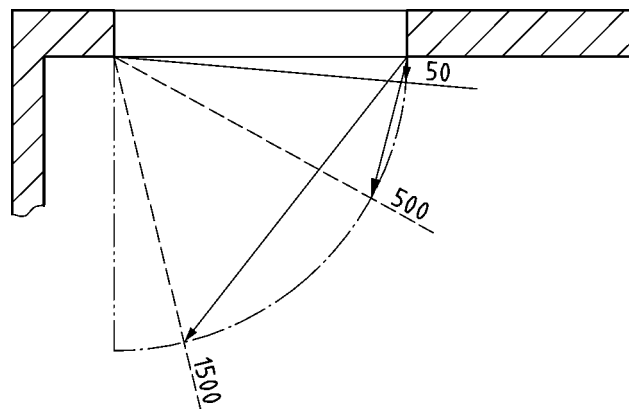

Figure C.4 — Gaps between the leaf of a hinged door and opposing closing edge

For each measuring point, the forces shall be measured in the direction orthogonal to the closing edge, in the plane specified by the closing door edge and the opposing closing edge.

In case of double hinged door both leaves are measured individually.

This is a preview of "DS/EN 12453:2017". Click here to purchase the full version from the ANSI store.

C.3.3.3 Measuring between the door leaf and neighbouring stiff parts of the surrounding

The forces shall be measured at the opening gap of 500 mm between the door leaf and neighbouring stiff parts of the surrounding (see Figure C.5) at right angles to the surface of the door leaf, at points situated.

- In case of flat surfaces: at a height of 1000 mm above the floor, at a distance of 1000 mm from the pivots of the door leaf or at the main closing edge of the door leaf when the width of the door leaf is < 1000 mm.
- In case of projecting parts: at the part of the door leaf with the greatest projection up to a height of 2000 mm above the floor.

NOTE Moving door leaves of a folding door are not considered to be neighbouring stiff parts.

Dimensions in millimetres

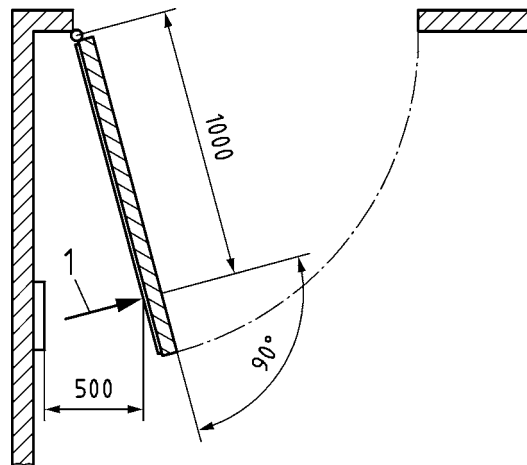

Key

- 1 direction of measuring force

Figure C.5 — Points of measuring at the leaf of a hinged door and an opening width between the leaf and neighbouring stiff parts of the surroundings

C.3.4 Folding door

C.3.4.1 General

On a folding door, the measurement of force shall be done in two different locations, specified as follows:

C.3.4.2 Measuring between the main closing edge and the opposing closing edge or between the main closing edges

Measurement of forces between the main closing edge and the opposing closing edge shall be carried out as required for sliding doors in C.3.2 (see Figure C.6).

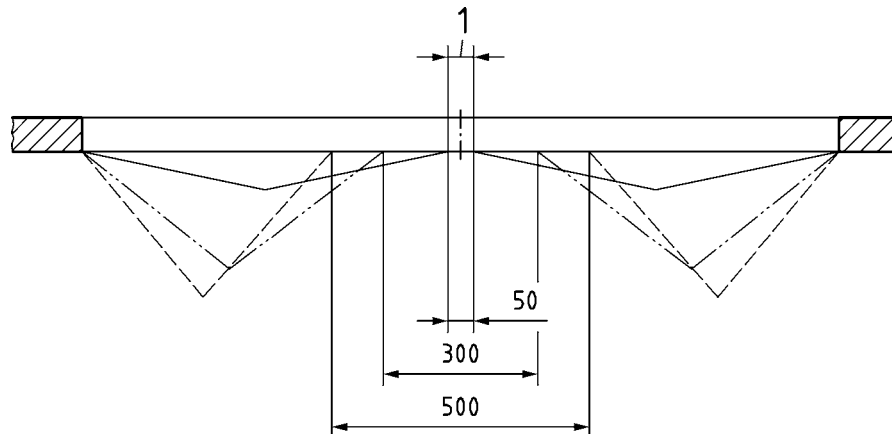
**Key**

- 1 direction of measuring force

Figure C.6 — Measurement of forces on a folding door

C.3.4.3 Measuring between the folding leaf and neighbouring stiff parts of the surroundings

Measurement of forces shall be carried out between a folding leaf and neighbouring stiff parts of surroundings as required for hinged doors in C.3.3.

C.3.5 Vertically moving doors

C.3.5.1 Measuring forces at the main closing edge

On any vertically moving door, forces shall be measured between the main closing edge and the opposing edge (floor) at the following points of the main closing edge (see Figure C.7):

- at a distance of 200 mm from each lateral border of the horizontal clear distance of the door opening and;
- at the centre of the clear opening.

Dimensions in millimetres

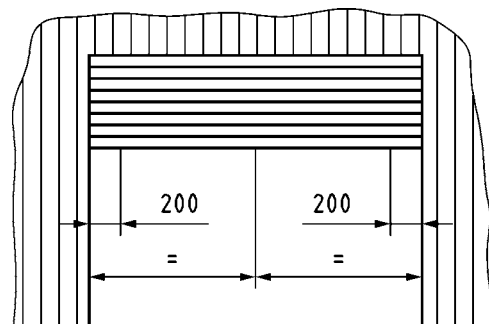

Figure C.7 — Points of measuring at the leaf of a lifting door

and at the opening gaps of (see Figure C.8)

- 50 mm;

This is a preview of "DS/EN 12453:2017". Click here to purchase the full version from the ANSI store.

- 300 mm;
- and 2500 mm, or, if the clear opening height is < 2800 mm, 300 mm below the fully open position of the door.

For up and over doors < 2800 mm in height, the measurement at 300 mm below the fully open position need not be taken if the vertical component of the movement is less than the horizontal component.

Dimensions in millimetres

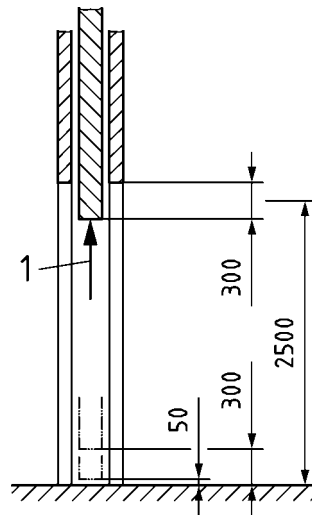

Key

- 1 direction of measuring force

Figure C.8 — Opening gaps between the main closing edge of a lifting door and the opposing closing edge

C.3.5.2 Measuring forces between secondary closing edge and opposing edge

When shearing hazards which occur on tilting doors between secondary closing edges are safeguarded by force limitation, forces shall be measured between the secondary closing edge and the opposing closing edge, perpendicular to the door leaf at a point located 300 mm away from the crossing or pivoting point with the opposing closing edge when the angle between the door leaf and the fixed edge is 30° (see Figure C.9).

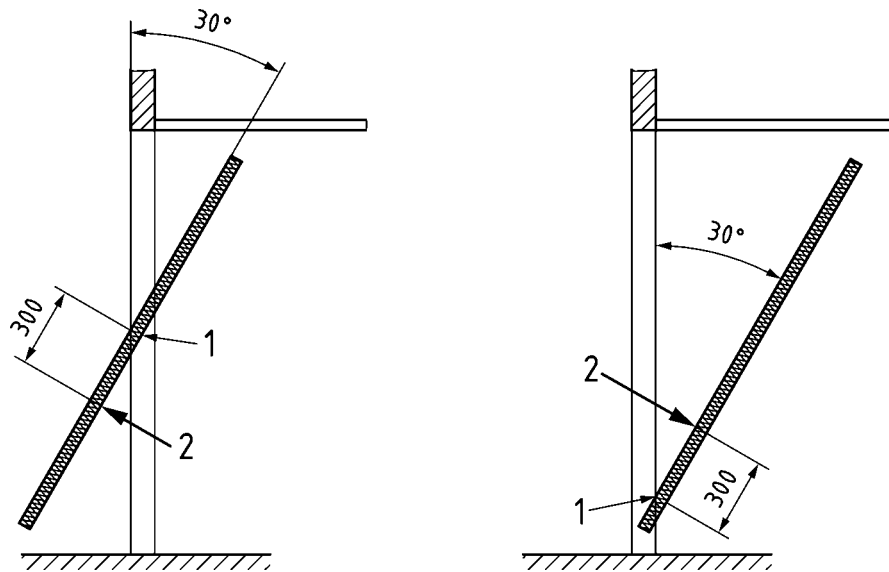
**Key**

- 1 crossing point
- 2 point of measuring

Figure C.9 — Point of measuring on secondary edge of a tilting door

Measurement of the forces on secondary closing edges may be disregarded if the manufacturer of the door can demonstrate that forces, when measured on the secondary closing edge are always below the values obtained when the measurement is done on the main closing edge, under the same measuring conditions e.g. active or passive safety devices fitted in the same way, hard against hard, etc.

C.3.6 Barriers

For barriers, the forces shall be measured at the measuring points specified below, in the direction perpendicular to the arm in the vertical plane between the arm to the ground.

The force shall be measured at 200 mm from the end of the arm, and at a maximum height of 2 m above the ground, and at an angle with the horizontal of maximum 45° (see Figure C.10).

When variable gaps between moving parts and the ground or fixed surroundings are decreasing during the downwards movement to < 300 mm, then measuring points have to be considered at gaps of 300 mm (see Figure C.10, right) and eventually 50 mm.

Dimensions in millimetres

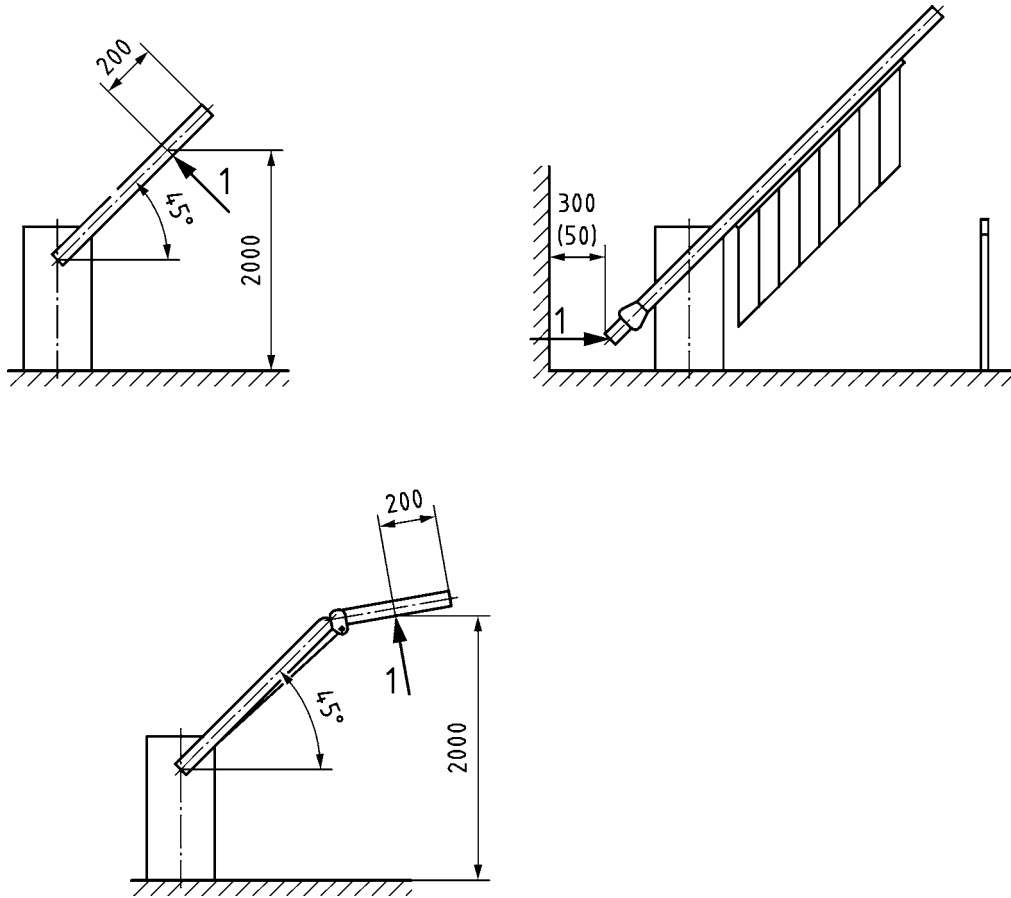

Figure C.10 — Points of measuring at barriers

This is a preview of "DS/EN 12453:2017". Click here to purchase the full version from the ANSI store.

Annex D (normative)

Testing method for presence detection

D.1 General

This Annex is applicable to ESPE based on AOPDs (Active Optoelectronic Protective Devices) using a radiation wavelength in the range 820 nm to 946 nm. For sensing devices using other technologies, the requirements of this standard with regard to the test piece dimensions, positioning and orientation shall be followed. However the material characteristics of the test pieces shall be as required by EN 12978 for the relevant sensing device.

D.2 Test pieces

The A test piece is a box with the dimensions 700 mm × 300 mm × 200 mm (see Figure D.1 a). Both the top side and two sides that meet are made of a material with a diffuse reflectance value in the range of 2 % to 5 % of the wavelength of the ESPE transmitter (e.g. IC antistatic foam; see also IEC 61496-3:2008, 4.2.13 for further materials) while the other two sides are made of a material with a diffuse reflectance value in the range of 80 % to 90 % of the wavelength of the ESPE transmitter (e.g. white paper). The base of the test piece is not defined as it does not serve any purpose in the test.

The B test piece is a hard cylinder 300 mm long, with an external diameter of 50 mm (see Figure D.1 b). Half of the outer surface shall be made of a material with a diffuse reflectance value in the range of 2 % to 5 % of the wavelength of the ESPE transmitter (e.g. IC antistatic foam; see also IEC 61496-3:2008, 4.2.13 for further materials) while the other half are made of a material with a diffuse reflectance value in the range of 80 % to 90 % of the wavelength of the ESPE transmitter (e.g. white paper). If more convenient, two B test pieces can be used, each one having reflectance values as specified above.

The tests shall always be performed with both reflectance surfaces.

Tests for ESPE using the background as a reference shall be performed with a background with a diffuse reflectance value of 20 % ± 5 % of the ESPE wavelength (e.g. carpet).

Dimensions in millimetres

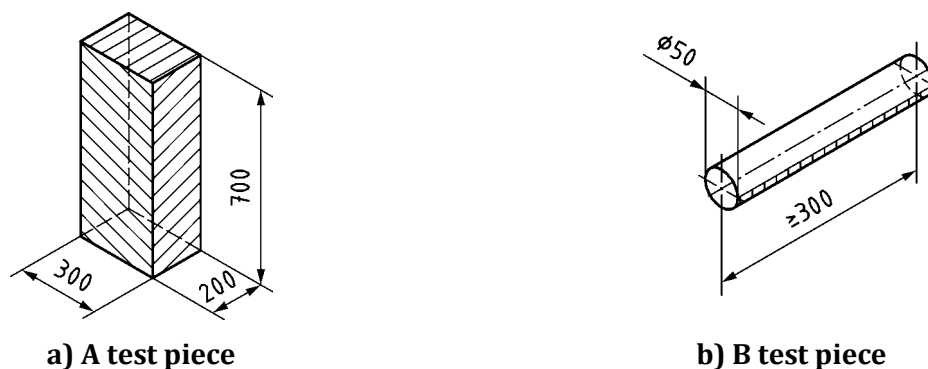

Key



diffuse reflectance value in the range of 2 % to 5 % at the wavelength of the transmitter of the ESPE



diffuse reflectance value in the range of 80 % to 90 % at the wavelength of the transmitter of the ESPE

Figure D.1 — Test pieces

D.3 Testing of supplementary device to be used with force limitation

D.3.1 General

Such device reduces the probability of contact of a person or an obstacle on the ground with the moving door and can be active on both sides of the door, or in the travel path of the door.

The detection capability shall be tested on the side(s) or in the path where the device is active.

When active on both sides, it shall be verified that no conflict appears between the two sides by checking that each test piece is correctly detected by the system active on the side of the door where the test piece is located.

D.3.2 Testing of horizontal sliding and folding doors, and any type of vertically moving doors including barriers

D.3.2.1 Device active on one side or in line with the door

The A test piece is laid on the ground (see Figure D.2); the A test piece shall be detected at any position beside or in line with the door aperture on the side where the presence detection equipment is active, or for barriers along the length of the barrier on the side where the presence detection equipment is active (see Figure D.3).

Figures D.2 and D.3 show the orientation of the test piece.

Dimensions in millimetres

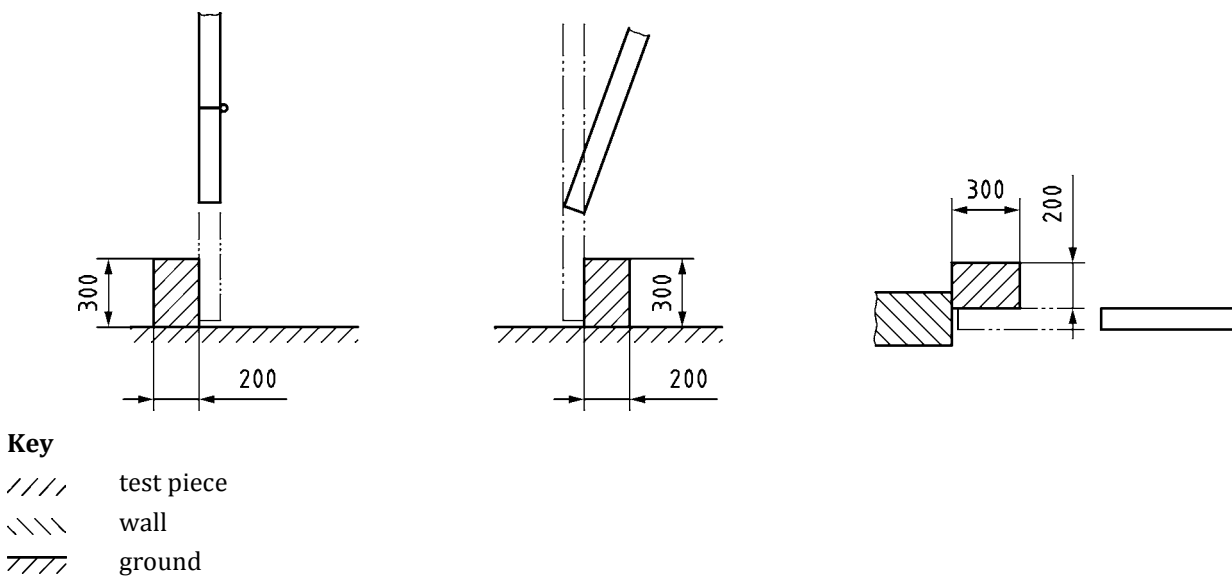
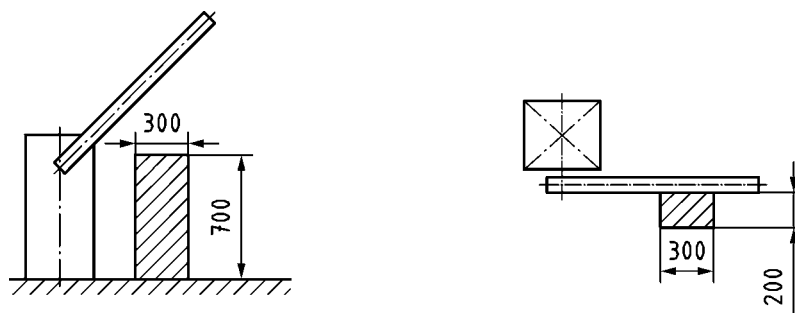

Figure D.2 — Testing of presence detection active on one side with the A test piece

This is a preview of "DS/EN 12453:2017". Click here to purchase the full version from the ANSI store.

Dimensions in millimetres



Key
 //// test piece
 //// ground

Figure D.3 — Testing a presence detection with the test piece A on a barrier

D.3.2.2 Device active on both sides

The position of the closed door or barrier edge shall be marked on the ground. When the door leaf (or barrier) is in the worst position, if one exists, and the two A test pieces are placed on the ground (see Figures D.4 or D.5), each of them shall be detected.

Dimensions in millimetres

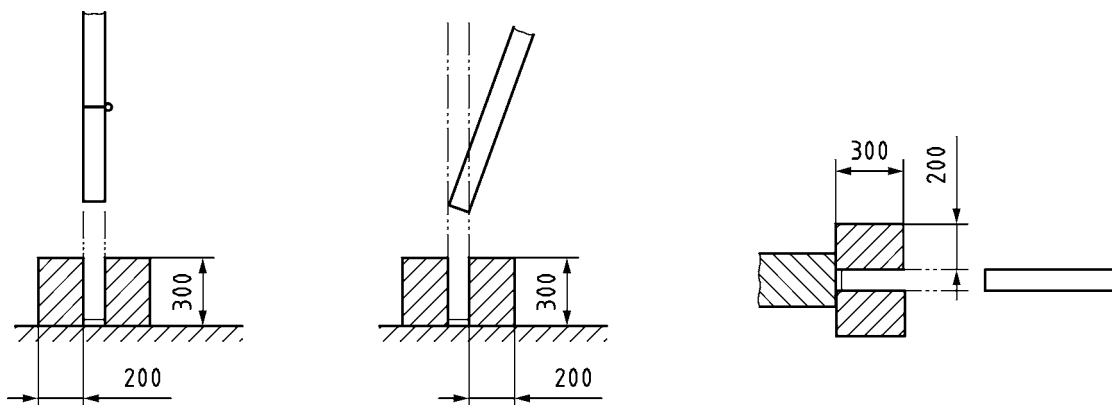

Key
 //// test piece
 \\\ wall
 //// ground

Figure D.4 — Testing of presence detection active on both sides with the A test piece

Dimensions in millimetres

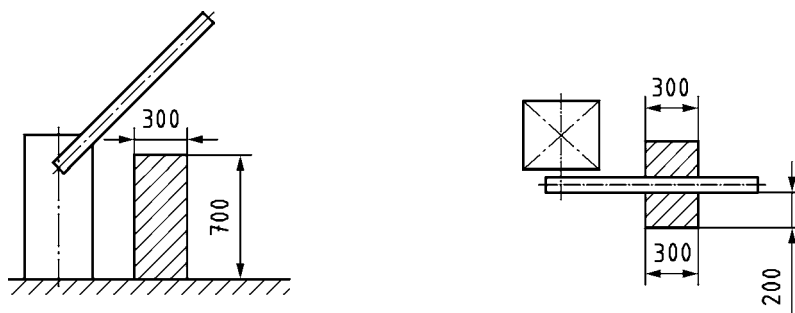

Key
 \\\ test piece
 /// ground

Figure D.5 — Testing of presence detection active on both sides on barriers

Dimensions in millimetres

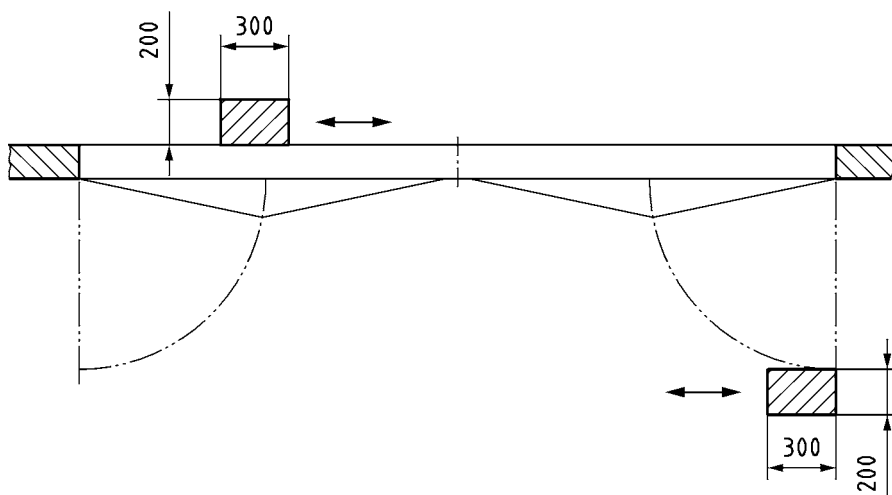

Key
 \\\ test piece
 \\\\ wall

Figure D.6 — Testing of presence detection active on both sides on folding doors

When moved in any position beside the door aperture, the A test piece placed on the inside, shall be detected by the inside presence detection equipment, and the A test piece placed on the outside, shall be detected by the outside presence detection equipment.

D.3.3 Testing of hinged doors

D.3.3.1 Device active to sense intrusion in the door leaf travel area

The projections of the door leaf, when closed and opened, are first drawn on the ground. Then the leaf is located in a half closed position.

This is a preview of "DS/EN 12453:2017". [Click here to purchase the full version from the ANSI store.](#)

When the door leaf is half closed, the two A test pieces located on the ground (see Figure D.7) shall be detected: the A test piece placed on the inside shall be detected by the inside presence detection, and the A test piece placed on the outside shall be detected by the outside presence detection.

Dimensions in millimetres

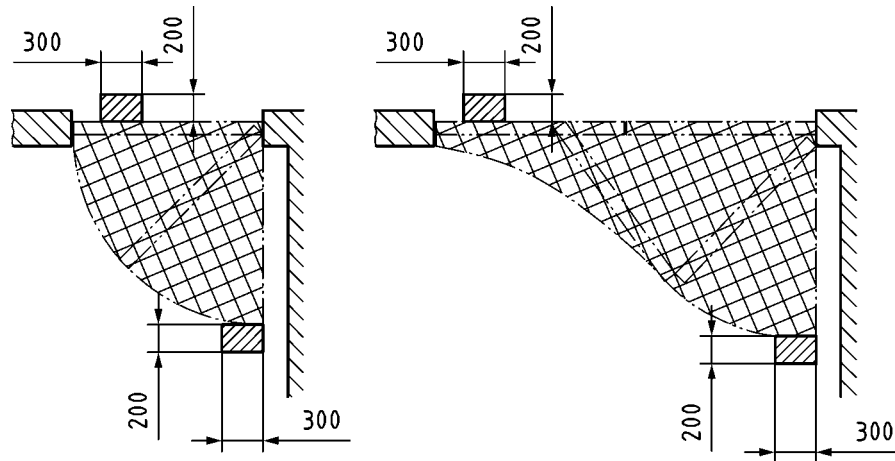

Key

- //// test piece
- \\\\ wall
- ⋈⋈⋈ projection

Figure D.7 — Testing of presence detection active on both sides on hinged doors

D.4 Testing of presence detection system to be used without force limitation

D.4.1 Testing of horizontal sliding and folding doors, and any type of vertically moving doors including barriers

D.4.1.1 Device active only in the plane of the door leaf

D.4.1.1.1 Device active in the door aperture to safeguard the main closing edge

The device shall be tested when the door is closing.

It shall be verified, by using the A test piece in its dimension 200 mm positioned anywhere in the plane in which the door leaf moves, that the test piece is detected and the door leaf shall stop or reverse without any contact to the test piece up to a height of 2 500 mm above floor level (see Figure D.8).

It shall be verified, by using the B test piece positioned, up to a height of 2 500 mm above floor level, anywhere in the plane in which the door leaf moves, that the test piece is detected and the door leaf shall stop or reverse without any contact to the test piece for the last 300 mm before full closed position (see Figure D.8)

Dimensions in millimetres

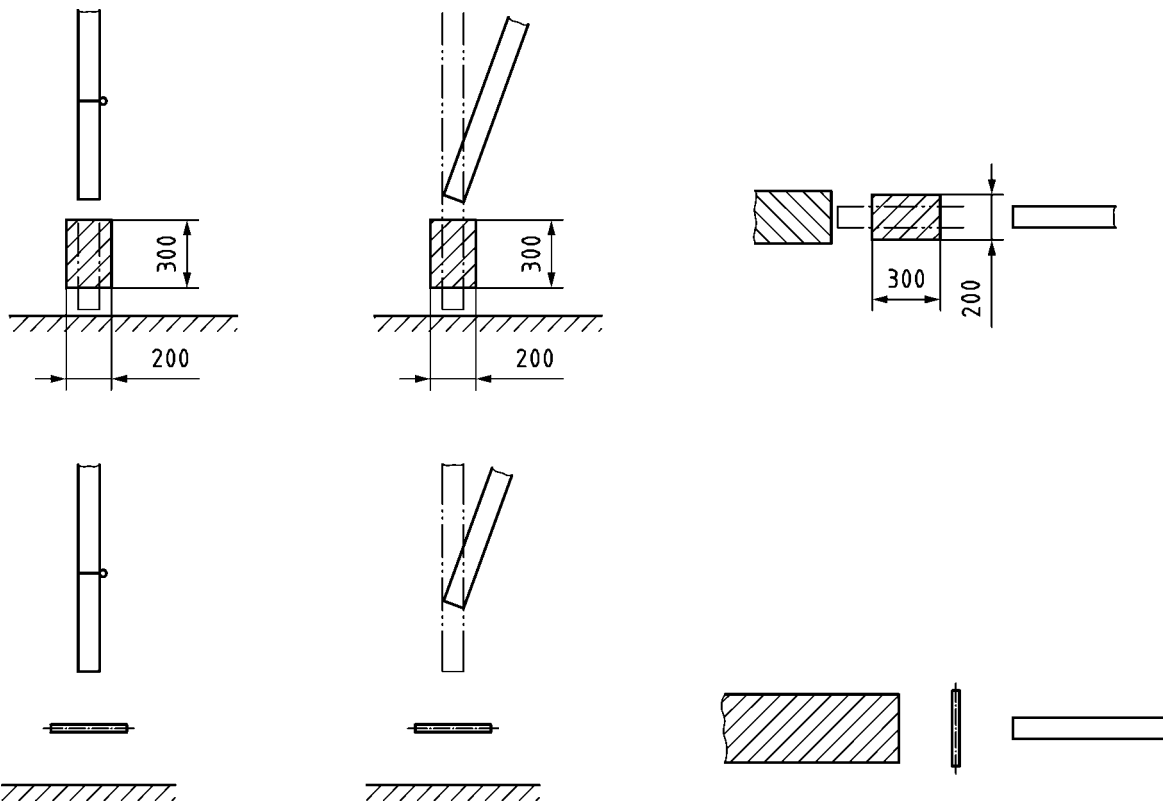

Key

- //// test piece
- \\ wall
- /// ground

Figure D.8 — Testing of presence detection active in the door aperture

D.4.1.1.2 Device used to safeguard hazardous areas other than the main closing edge

The hazardous area is specified as the projection on the ground of the volume containing the door leaf in any position during movement up to a height of 2,5 m above the floor.

The device shall be tested when the door is opening and when the door is closing. It shall be verified, by using the B test piece positioned anywhere in the hazardous area up to a height of 2 500 mm, that the test piece is detected and the door leaf stops or reverses without any contact to the test piece.

NOTE A hazardous area other than the main closing edge can be e.g. the area between the rear edge of a sliding door or gate and a wall angle or between bars in a sliding gate and posts or support columns.

D.4.1.2 Device active in the hazardous area of the movement of the door leaf

The hazardous area is specified as the projection on the ground of the volume containing the door leaf in any position during movement up to a height of 2,5 m above the floor and increased by a safety distance “d” in any direction. The safety distance “d” shall be related to closing speed, height of the door and be at least 200 mm and be declared in the installation instructions of the door (see Figure D.9).

The test is carried out using the A test piece.

This is a preview of "DS/EN 12453:2017". [Click here to purchase the full version from the ANSI store.](#)

It shall be verified, by using the A test piece, positioned on the ground and orientated according to Figure D.9.

- if the A test piece encroaches anywhere on the hazardous area, when the door is closing, the door leaf stops and/or reverses and no contact occurs between the door leaf and the A test piece. This test shall also be made when door is opening, for hinged and folding doors.
- if the A test piece is located anywhere in the hazardous area, when the door is closing, the door leaf stops and/or reverses and no contact occurs between the door leaf and the A test piece.
- whilst the A test piece is in the hazardous area the door leaf is prevented from any hazardous movement.

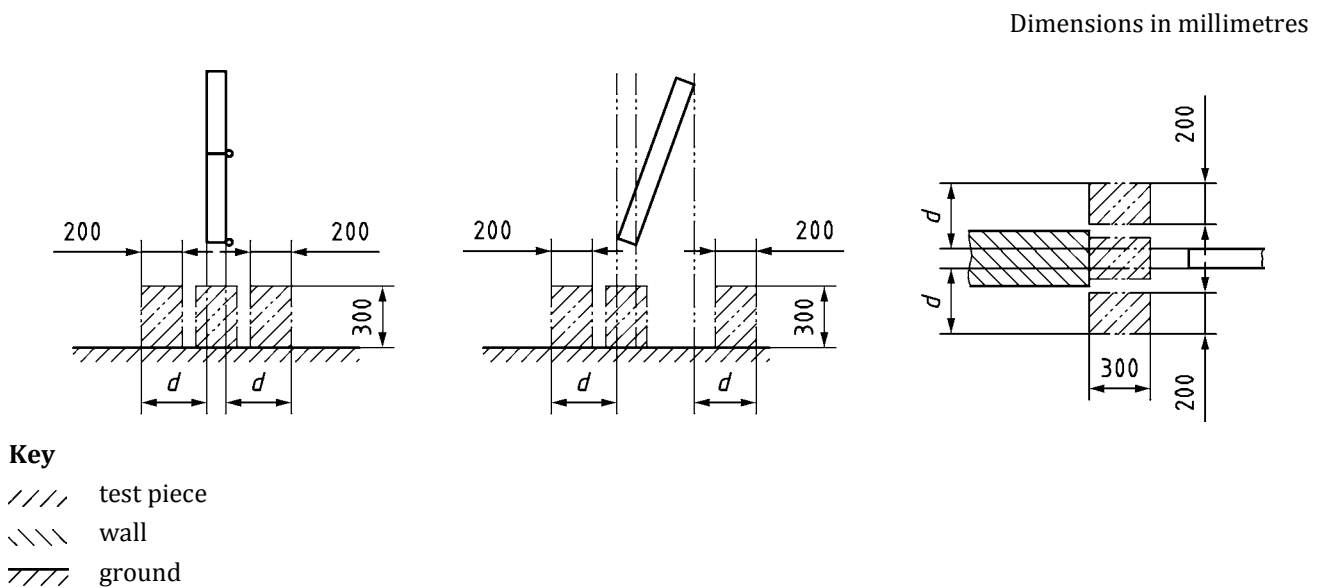

Figure D.9 — Testing of presence detection system providing a safety distance

D.4.2 — Testing of hinged doors

The device shall be tested when the door is opening and when the door is closing.

It shall be verified, by using the A test piece positioned vertically on the ground and anywhere in the swept area in which the door leaf moves, that the test piece is detected and the door leaf stops or reverses without any contact to the test piece (see Figure D.10).

If the device is used to safeguard closing gaps, it shall be verified by using the B test piece positioned anywhere in the hazardous area up to a height of 2 500 mm, that the test piece is detected and the door leaf stops or reverses without any contact to the test piece.

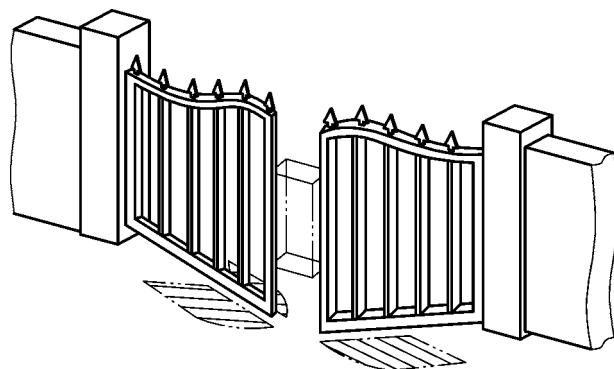

Figure D.10 — Testing presence detection devices on hinged doors

This is a preview of "DS/EN 12453:2017". [Click here to purchase the full version from the ANSI store.](#)

Annex E (informative)

Safeguarding against dropping by other design features incorporated in the suspension system of vertically moving power operated door leaves

When safeguards against dropping can be achieved via other design features, the following design features, if they fulfil all the applicable requirements of 5.5.4, are acceptable solutions:

- Doors equipped with suspension systems (with or without springs) like steel wire ropes, straps or chains so designed that
 - in the event of a failure of one suspension element, the other suspension element(s) can carry the panel and hold it in position;
 - and
 - the drive/drive unit can bear the resulting out of balance state in the event of a failure of the suspension element without creating additional hazards.
- The door leaf is driven by two drives/drive units and each drive/drive unit is designed to be able to independently carry the weight of the door leaf in the case of failure of the other drive/drive unit. A further movement of the door leaf is automatically prohibited at the latest when the door leaf has reached its lower terminal point.

Annex F
(informative)

Relationship between Hazards, Requirements and Test clauses

Table F.1 shows the relationship between hazards clauses of this European Standard (Clause 4) and relevant requirements (Clause 5) and test methods (Clause 6).

Table F.1 — Relationship between hazards clauses of this European Standard, relevant requirements and test methods

Type of hazards (EN ISO 12100:2010, B.1)	List of significant hazards clause/subclause	Safety requirements and/or protective measures clause/subclause	Verification of the safety requirements and/or protective measures clause/subclause
Mechanical	4.2	5.2	6.2
	4.2.1	5.2.1	6.2.1
	4.2.1, first indent	5.2.1.2 5.2.1.3 5.2.1.5 5.2.1.6 5.2.1.7	6.2.1.2 6.2.1.3 6.2.1.5 6.2.1.6 6.2.1.7
	4.2.1, second indent	5.2.1.5 5.2.1.6 5.2.1.7	6.2.1.5 6.2.1.6 6.2.1.7
	4.2.1, third indent	5.2.1.2 5.2.1.3 5.2.1.5 5.2.1.6 5.2.1.7	6.2.1.2 6.2.1.3 6.2.1.5 6.2.1.6 6.2.1.7
	4.2.1, fourth indent	5.2.1.2 5.2.1.3 5.2.1.5 5.2.1.6 5.2.1.7	6.2.1.2 6.2.1.3 6.2.1.5 6.2.1.6 6.2.1.7
	4.2.1, fifth indent	5.2.1.4	6.2.1.4
	4.2.1, sixth indent	5.2.1.3 5.2.1.5	6.2.1.3 6.2.1.5

This is a preview of "DS/EN 12453:2017". [Click here to purchase the full version from the ANSI store.](#)

Type of hazards (EN ISO 12100:2010, B.1)	List of significant hazards clause/subclause	Safety requirements and/or protective measures clause/subclause	Verification of the safety requirements and/or protective measures clause/subclause
Mechanical	4.2.1, seventh indent	5.2.1.2 5.2.1.3 5.2.1.5 5.2.1.6 5.2.1.7	6.2.1.2 6.2.1.3 6.2.1.5 6.2.1.6 6.2.1.7
	4.2.2	5.2.2	6.2.2
	4.2.3	5.2.3	6.2.3
Electrical	4.3, first to fourth indents	5.3.2 or 5.3.3 or 5.3.4 and 5.3.6	6.3.1 or 6.3.2 or 6.3.3 and 6.3.5
	4.3, fifth indent	5.3.5	6.3.4
	4.4, first, second and fourth indents	5.4.2 5.4.3 5.4.4	6.4.1 6.4.2 6.4.3
Ergonomic	4.4, third indent	5.4.5	6.4.4
Mechanical	4.5.2	5.5.1	6.5.1
	4.5.3	5.5.2	6.5.2
	4.5.4	5.5.3	6.5.3
	4.5.5	5.5.4	6.5.4
	4.5.6	5.5.5	6.5.5
	4.5.7	5.5.6	6.5.6
	4.5.8	5.5.7	6.5.7
	4.5.9	5.5.8	6.5.8

This is a preview of "DS/EN 12453:2017". [Click here to purchase the full version from the ANSI store.](#)

Annex ZA (informative)

Relationship between this European standard and the Essential Requirements of Directive 2006/42/EC aimed to be covered

This European standard has been prepared under a Commission's standardization request M/396 to provide one voluntary means of conforming to Essential Requirements of Directive 2006/42/EC of the European Parliament and of the Council of 17 May 2006 on machinery, and amending Directive 95/16/EC (recast).

Once this standard is cited in the Official Journal of the European Union under that Directive, compliance with the normative clauses of this standard given in Table ZA.1 confers, within the limits of the scope of this standard, a presumption of conformity with the corresponding Essential Requirements of that Directive, and associated EFTA regulations.

Table ZA.1 — Correspondence between this European standard and Annex I of Directive 2006/42/EC

Essential Requirements of Directive	Clause(s)/subclause(s) of this EN	Remarks / Notes
All requirements are covered	All clauses	-

WARNING 1: Presumption of conformity stays valid only as long as a reference to this European standard is maintained in the list published in the Official Journal of the European Union. Users of this standard should consult frequently the latest list published in the Official Journal of the European Union.

WARNING 2: Other Union legislation may be applicable to the product(s) falling within the scope of this standard.

This is a preview of "DS/EN 12453:2017". [Click here to purchase the full version from the ANSI store.](#)

Bibliography

IEC 61496-3:2008, *Safety of machinery — Electro-sensitive protective equipment — Part 3: Particular requirements for Active Opto-electronic Protective Devices responsive to Diffuse Reflection*