

This is a preview of "DS/IEC 60092-360:202...". Click here to purchase the full version from the ANSI store.

Elektriske installationer i skibe – Del 360: Isolerings- og kappematerialer til skibs- og offshoreenheder, strøm-, styre-, instrumenterings- og telekommunikationskabler

Electrical installations in ships – Part 360: Insulating and sheathing materials for shipboard and offshore units, power, control, instrumentation and telecommunication cables

DANSK STANDARD
Danish Standards Association

Göteborg Plads 1
DK-2150 Nordhavn

Tel: +45 39 96 61 01
dansk.standard@ds.dk
www.ds.dk

This is a preview of "DS/IEC 60092-360:202...". Click here to purchase the full version from the ANSI store.

DS projekt: M344009

ICS: 47.020.60

Første del af denne publikations betegnelse er:

DS/IEC, hvilket betyder, at det er en international standard, der har status som dansk standard.

Denne publikations overensstemmelse er:

IDT med: IEC 60092-360:2021

DS-publikationen er på engelsk.

Denne publikation erstatter: [DS/IEC 60092-360:2014](#)

DS-publikationstyper

Dansk Standard udgiver forskellige publikationstyper.

Typen på denne publikation fremgår af forsiden.

Der kan være tale om:

Dansk standard

- standard, der er udarbejdet på nationalt niveau, eller som er baseret på et andet lands nationale standard, eller
- standard, der er udarbejdet på internationalt og/eller europæisk niveau, og som har fået status som dansk standard

DS-information

- publikation, der er udarbejdet på nationalt niveau, og som ikke har opnået status som standard, eller
- publikation, der er udarbejdet på internationalt og/eller europæisk niveau, og som ikke har fået status som standard, fx en teknisk rapport, eller
- europæisk præstandard

DS-håndbog

- samling af standarder, eventuelt suppleret med informativt materiale

DS-hæfte

- publikation med informativt materiale

Til disse publikationstyper kan endvidere udgives

- tillæg og rettelsesblade

DS-publikationsform

Publikationstyperne udgives i forskellig form som henholdsvis

- fuldttekstpublikation (publikationen er trykt i sin helhed)
- godkendelsesblad (publikationen leveres i kopi med et trykt DS-omslag)
- elektronisk (publikationen leveres på et elektronisk medie)

DS-betegnelse

Alle DS-publikationers betegnelse begynder med DS efterfulgt af et eller flere præfikser og et nr., fx **DS 383**, **DS/EN 5414** osv. Hvis der efter nr. er angivet et **A** eller **Cor**, betyder det, enten at det er et **tillæg** eller et **rettelsesblad** til hovedstandard, eller at det er indført i hovedstandard.

DS-betegnelse angives på forsiden.

Overensstemmelse med anden publikation:

Overensstemmelse kan enten være IDT, EQV, NEQ eller MOD

- **IDT:** Når publikationen er identisk med en given publikation.
- **EQV:** Når publikationen teknisk er i overensstemmelse med en given publikation, men præsentationen er ændret.
- **NEQ:** Når publikationen teknisk eller præsentationsmæssigt ikke er i overensstemmelse med en given standard, men udarbejdet på baggrund af denne.
- **MOD:** Når publikationen er modificeret i forhold til en given publikation.

This is a preview of "DS/IEC 60092-360:2021...". Click here to purchase the full version from the ANSI store.



Edition 2.0 2021-01

INTERNATIONAL STANDARD

**Electrical installations in ships –
Part 360: Insulating and sheathing materials for shipboard and offshore units,
power, control, instrumentation and telecommunication cables**



This is a preview of "DS/IEC 60092-360:202...". Click here to purchase the full version from the ANSI store.



THIS PUBLICATION IS COPYRIGHT PROTECTED

Copyright © 2021 IEC, Geneva, Switzerland

All rights reserved. Unless otherwise specified, no part of this publication may be reproduced or utilized in any form or by any means, electronic or mechanical, including photocopying and microfilm, without permission in writing from either IEC or IEC's member National Committee in the country of the requester. If you have any questions about IEC copyright or have an enquiry about obtaining additional rights to this publication, please contact the address below or your local IEC member National Committee for further information.

IEC Central Office
3, rue de Varembe
CH-1211 Geneva 20
Switzerland

Tel.: +41 22 919 02 11
info@iec.ch
www.iec.ch

About the IEC

The International Electrotechnical Commission (IEC) is the leading global organization that prepares and publishes International Standards for all electrical, electronic and related technologies.

About IEC publications

The technical content of IEC publications is kept under constant review by the IEC. Please make sure that you have the latest edition, a corrigendum or an amendment might have been published.

IEC publications search - webstore.iec.ch/advsearchform

The advanced search enables to find IEC publications by a variety of criteria (reference number, text, technical committee, ...). It also gives information on projects, replaced and withdrawn publications.

IEC Just Published - webstore.iec.ch/justpublished

Stay up to date on all new IEC publications. Just Published details all new publications released. Available online and once a month by email.

IEC Customer Service Centre - webstore.iec.ch/csc

If you wish to give us your feedback on this publication or need further assistance, please contact the Customer Service Centre: sales@iec.ch.

IEC online collection - oc.iec.ch

Discover our powerful search engine and read freely all the publications previews. With a subscription you will always have access to up to date content tailored to your needs.

Electropedia - www.electropedia.org

The world's leading online dictionary on electrotechnology, containing more than 22 000 terminological entries in English and French, with equivalent terms in 18 additional languages. Also known as the International Electrotechnical Vocabulary (IEV) online.

This is a preview of "DS/IEC 60092-360:202...". Click here to purchase the full version from the ANSI store.



Edition 2.0 2021-01

INTERNATIONAL STANDARD

**Electrical installations in ships –
Part 360: Insulating and sheathing materials for shipboard and offshore units,
power, control, instrumentation and telecommunication cables**

INTERNATIONAL
ELECTROTECHNICAL
COMMISSION

ICS 47.020.60

ISBN 978-2-8322-9229-7

Warning! Make sure that you obtained this publication from an authorized distributor.

CONTENTS

FOREWORD	4
1 Scope	6
2 Normative references	6
3 Terms and definitions	7
4 Cross-linked insulating compounds	9
4.1 General	9
4.2 Electrical characteristics	9
4.3 Mechanical characteristics	10
5 Cross-linked sheathing compounds	13
5.1 General	13
5.2 Mechanical characteristics	13
6 Thermoplastic sheathing compounds	15
6.1 General	15
6.2 Mechanical characteristics	16
7 Additional optional properties of sheathing compounds	17
7.1 General	17
7.2 Test requirements	17
Annex A (normative) Determination of hardness of HEPR insulation	19
A.1 Test piece	19
A.2 Test procedure	19
A.2.1 General	19
A.2.2 Surfaces of large radius of curvature	19
A.2.3 Surfaces of small radius of curvature	20
A.2.4 Conditioning and test temperature	20
A.2.5 Number of measurements	21
Annex B (normative) Determination of the elastic modulus of HEPR insulation	22
B.1 Procedure	22
B.2 Requirements	22
Annex C (normative) Procedure for enhanced hot oil immersion test for sheaths	23
C.1 Sampling and preparation of the test pieces	23
C.2 Determination of the cross-sectional area of the test piece	23
C.3 Oil to be used	23
C.4 Procedure	23
C.5 Expression of results	23
C.6 Requirements	24
Annex D (normative) Procedure for drilling fluid immersion test for sheaths	25
D.1 Drilling fluid resistance test	25
D.2 Test fluids	25
D.3 Procedure	25
D.4 Expression of results	25
D.5 Requirements	26
Figure A.1 – Testing surfaces of large radius of curvature	19
Figure A.2 – Testing surfaces of small radius of curvature	20

This is a preview of "DS/IEC 60092-360:2021". [Click here to purchase the full version from the ANSI store.](#)

Table 1 – Categories and types of materials	6
Table 2 – Types of cross-linked insulating compounds.....	9
Table 3 – Electrical requirements of insulation compounds	10
Table 4 – Test requirements for cross-linked elastomeric insulating compounds	11
Table 5 – Types of cross-linked sheathing compound	13
Table 6 – Test requirements for cross-linked sheathing compounds.....	14
Table 7 – Types of thermoplastic sheathing compound	16
Table 8 – Test requirements for thermoplastic sheathing compounds.....	16
Table 9 – Test requirements for sheathing compounds with enhanced oil resistance properties	18
Table 10 – Test requirements for sheathing compounds with drilling fluids resistance properties (test for mud resistance).....	18

INTERNATIONAL ELECTROTECHNICAL COMMISSION

ELECTRICAL INSTALLATIONS IN SHIPS –

Part 360: Insulating and sheathing materials for shipboard and offshore units, power, control, instrumentation and telecommunication cables

FOREWORD

- 1) The International Electrotechnical Commission (IEC) is a worldwide organization for standardization comprising all national electrotechnical committees (IEC National Committees). The object of IEC is to promote international co-operation on all questions concerning standardization in the electrical and electronic fields. To this end and in addition to other activities, IEC publishes International Standards, Technical Specifications, Technical Reports, Publicly Available Specifications (PAS) and Guides (hereafter referred to as "IEC Publication(s)"). Their preparation is entrusted to technical committees; any IEC National Committee interested in the subject dealt with may participate in this preparatory work. International, governmental and non-governmental organizations liaising with the IEC also participate in this preparation. IEC collaborates closely with the International Organization for Standardization (ISO) in accordance with conditions determined by agreement between the two organizations.
- 2) The formal decisions or agreements of IEC on technical matters express, as nearly as possible, an international consensus of opinion on the relevant subjects since each technical committee has representation from all interested IEC National Committees.
- 3) IEC Publications have the form of recommendations for international use and are accepted by IEC National Committees in that sense. While all reasonable efforts are made to ensure that the technical content of IEC Publications is accurate, IEC cannot be held responsible for the way in which they are used or for any misinterpretation by any end user.
- 4) In order to promote international uniformity, IEC National Committees undertake to apply IEC Publications transparently to the maximum extent possible in their national and regional publications. Any divergence between any IEC Publication and the corresponding national or regional publication shall be clearly indicated in the latter.
- 5) IEC itself does not provide any attestation of conformity. Independent certification bodies provide conformity assessment services and, in some areas, access to IEC marks of conformity. IEC is not responsible for any services carried out by independent certification bodies.
- 6) All users should ensure that they have the latest edition of this publication.
- 7) No liability shall attach to IEC or its directors, employees, servants or agents including individual experts and members of its technical committees and IEC National Committees for any personal injury, property damage or other damage of any nature whatsoever, whether direct or indirect, or for costs (including legal fees) and expenses arising out of the publication, use of, or reliance upon, this IEC Publication or any other IEC Publications.
- 8) Attention is drawn to the Normative references cited in this publication. Use of the referenced publications is indispensable for the correct application of this publication.
- 9) Attention is drawn to the possibility that some of the elements of this IEC Publication may be the subject of patent rights. IEC shall not be held responsible for identifying any or all such patent rights.

International Standard IEC 60092-360 has been prepared by Subcommittee 18A: Electric cables for ships and mobile and fixed offshore units, of IEC Technical Committee 18: Electrical installations of ships and of mobile and fixed offshore units.

This second edition cancels and replaces the first edition published in 2014. This edition constitutes a technical revision.

This edition includes the following significant technical changes with respect to the previous edition:

- a) updates of normative references;
- b) replacement of linear swelling with volume swelling;
- c) correction of a calculation mistake in Table 3;

This is a preview of "DS/IEC 60092-360:202...". [Click here to purchase the full version from the ANSI store.](#)

- d) change in Table 4 and Table 6 (treatment conditions) of time under load (from 15 min to 10 min);
- e) addition of mechanical properties after aging in oil based test fluid in Table 10 (CAS number 64742-46-7; EC number: 934-956-3).

The text of this document is based on the following documents:

FDIS	Report on voting
18A/437/FDIS	18A/440/RVD

Full information on the voting for the approval of this International Standard can be found in the report on voting indicated in the above table.

This document has been drafted in accordance with the ISO/IEC Directives, Part 2.

A list of all parts of the IEC 60092 series, published under the general title *Electrical installations in ships*, can be found on the IEC website.

The committee has decided that the contents of this document will remain unchanged until the stability date indicated on the IEC website under "<http://webstore.iec.ch>" in the data related to the specific document. At this date, the document will be

- reconfirmed,
- withdrawn,
- replaced by a revised edition, or
- amended.

ELECTRICAL INSTALLATIONS IN SHIPS –**Part 360: Insulating and sheathing materials for shipboard and offshore units, power, control, instrumentation and telecommunication cables****1 Scope**

This part of IEC 60092 specifies the requirements for electrical, mechanical and particular characteristics of insulating and sheathing materials intended for use in shipboard and fixed and mobile offshore unit power, control, instrumentation and telecommunication cables.

The different insulating and sheathing materials have been divided into three categories as listed in Table 1.

Table 1 – Categories and types of materials

Title	Compounds included
Cross-linked insulating compounds	EPR; HEPR; XLPE; S 95; HF 90
Cross-linked sheathing compounds	SE; SH; SHF 2
Thermoplastic sheathing compounds	SHF 1; ST 2

2 Normative references

The following documents, in whole or in part, are normatively referenced in this document and are indispensable for its application. For dated references, only the edition cited applies. For undated references, the latest edition of the referenced document (including any amendments) applies.

IEC 60092-350:2020, *Electrical installations in ships – Part 350: General construction and test methods of power, control and instrumentation cables for shipboard and offshore applications*

IEC 60684-2:2011, *Flexible insulating sleeving – Part 2: Methods of test*

IEC 60754-1, *Test on gases evolved during combustion of materials from cables – Part 1: Determination of the halogen acid gas content*

IEC 60754-2, *Test on gases evolved during combustion of materials from cables – Part 2: Determination of acidity (by pH measurement) and conductivity*

IEC 60811-201:2012, *Electric and optical fibre cables – Test methods for non-metallic materials – Part 201: General tests – Measurement of insulation thickness*
IEC 60811-201:2012/AMD1:2017

IEC 60811-202:2012, *Electric and optical fibre cables – Test methods for non-metallic materials – Part 202: General tests – Measurement of thickness of non-metallic sheath*
IEC 60811-202:2012/AMD1:2017

IEC 60811-401:2012, *Electric and optical fibre cables – Test methods for non-metallic materials – Part 401: Miscellaneous tests – Thermal ageing methods – Ageing in an air oven*
IEC 60811-401:2012/AMD1:2017

This is a preview of "DS/IEC 60092-360:202...". Click here to purchase the full version from the ANSI store.

IEC 60811-403:2012, *Electric and optical fibre cables – Test methods for non-metallic materials – Part 403: Miscellaneous tests – Ozone resistance test on cross-linked compounds*

IEC 60811-404:2012, *Electric and optical fibre cables – Test methods for non-metallic materials – Part 404: Miscellaneous tests – Mineral oil immersion tests for sheaths*

IEC 60811-409:2012, *Electric and optical fibre cables – Test methods for non-metallic materials – Part 409: Miscellaneous tests – Loss of mass test for thermoplastic insulations and sheaths*

IEC 60811-501:2012, *Electric and optical fibre cables – Test methods for non-metallic materials – Part 501: Mechanical tests – Tests for determining the mechanical properties of insulating and sheathing compounds*

IEC 60811-501:2012/AMD1:2018

IEC 60811-505:2012, *Electric and optical fibre cables – Test methods for non-metallic materials – Part 505: Mechanical tests – Elongation at low temperature for insulations and sheaths*

IEC 60811-507:2012, *Electric and optical fibre cables – Test methods for non-metallic materials – Part 507: Mechanical tests – Hot set test for cross-linked materials*

IEC 60811-508:2012, *Electric and optical fibre cables – Test methods for non-metallic materials – Part 508: Mechanical tests – Pressure test at high temperature for insulation and sheaths*

IEC 60811-508:2012/AMD1:2017

IEC 60811-509:2012, *Electric and optical fibre cables – Test methods for non-metallic materials – Part 509: Mechanical tests – Test for resistance of insulations and sheaths to cracking (heat shock test)*

IEC 60811-509:2012/AMD1:2017

ISO 48-2:2018, *Rubber, vulcanised or thermoplastic – Determination of hardness – Part 2: Hardness between 10 IRHD and 100 IRHD*

ISO 1817, *Rubber, vulcanised or thermoplastic – Determination of the effect of liquids*

3 Terms and definitions

For the purposes of this document, the following terms and definitions apply.

ISO and IEC maintain terminological databases for use in standardization at the following addresses:

- IEC Electropedia: available at <http://www.electropedia.org/>
- ISO Online browsing platform: available at <http://www.iso.org/obp>

3.1 variation

difference between the median value after ageing and the median value without ageing

Note 1 to entry: Variation is expressed as a percentage between the median value before and after ageing.

This is a preview of "DS/IEC 60092-360:202...". [Click here to purchase the full version from the ANSI store.](#)

3.2

median value

middle value if the number of available values is odd and mean of the two middle values if the number is even, when several test results have been obtained and ordered in an increasing or decreasing succession

3.3

types of insulating compounds

3.3.1

EPR

ethylene-propylene rubber

cross-linked compound in which the elastomer is an ethylene-propylene, EPDM or an equivalent synthetic elastomer providing a compound compliant with type EPR

3.3.2

HEPR

hard ethylene-propylene rubber

cross-linked high modulus or hard grade compound in which the elastomer is an ethylene-propylene, EPDM or an equivalent synthetic elastomer providing a compound compliant with type HEPR

3.3.3

XLPE

cross-linked polyethylene

cross-linked compound in which the polymer is a low density polyethylene or equivalent synthetic polymer providing a compound compliant with type XLPE

3.3.4

HF 90

cross-linked polyolefin halogen-free

cross-linked compound in which the polymer is a polyolefin or equivalent synthetic polymer not containing halogens providing a compound which is compliant with type HF 90

3.3.5

S 95

cross-linked silicone rubber

compound based on a polysiloxane elastomer which, when cross-linked, is compliant with type S 95

3.4

types of sheathing compounds

3.4.1

SE

polychloroprene rubber

cross-linked compound in which the elastomer is a polychloroprene (PCP) or equivalent synthetic elastomer providing a compound which is compliant with type SE

3.4.2

SH

chlorosulphonated polyethylene rubber

chlorinated polyethylene rubber

cross-linked compound in which the characteristic constituent is a synthetic chlorinated rubber

EXAMPLE Chlorosulphonated polyethylene (CSP) or chlorinated polyethylene (CPE), which is compliant with type SH.

This is a preview of "DS/IEC 60092-360:202...". Click here to purchase the full version from the ANSI store.

3.4.3**SHF 2****halogen-free rubber**

cross-linked compound in which the polymer is a polyolefin or equivalent synthetic polymer, not containing halogens, providing a compound which is compliant with type SHF 2

3.4.4**SHF 1****halogen-free thermoplastic**

thermoplastic compound in which the polymer is a polyolefin or equivalent synthetic polymer not containing halogens providing a compound which is compliant with type SHF 1

3.4.5**ST 2****polyvinyl chloride thermoplastic**

thermoplastic compound based on plasticised polyvinyl chloride which is compliant with type ST 2

3.5**halogen-free**

compound that complies with the assessment of halogen requirements in Table 4, Table 6 or Table 8

4 Cross-linked insulating compounds**4.1 General**

The types of cross-linked insulating compound covered by this document are listed in Table 2 together with their abbreviated designations and maximum rated conductor temperatures during normal operation and short-circuit.

Table 2 – Types of cross-linked insulating compounds

Abbreviated designation	Maximum rated conductor temperature °C		Type of insulating material
	Normal operation	Short-circuit	
EPR	90	250	Ethylene propylene rubber
HEPR	90	250	Hard grade ethylene propylene rubber
XLPE	90	250	Cross-linked polyethylene
HF 90	90	250	Cross-linked polyolefin halogen-free
S 95	95 ^a	350 ^b	Cross-linked silicone rubber
^a The normal maximum rated conductor temperature for silicone is 180 °C but it is limited in view of the type of sheathing material used.			
^b This temperature is applicable only to power cables and is not appropriate for tinned conductors.			

4.2 Electrical characteristics

The test requirements for electrical characteristics of insulating compounds are listed in Table 3.

This is a preview of "DS/IEC 60092-360:202...". [Click here to purchase the full version from the ANSI store.](#)

Table 3 – Electrical requirements of insulation compounds

Designation of the insulating compound	EPR	HEPR	XLPE	HF 90	S 95
Insulation resistance constant K_i ($M\Omega \cdot km$) (see 7.2 of IEC 60092-350:2020)					
– at 20 °C, minimum,	3 670	3 670	3 670	550	1 850
– at maximum operating temperature, minimum.	3,67	3,67	3,67	0,55	1,85
Volume resistivity ρ ($\Omega \cdot cm$) (see 7.2 of IEC 60092-350:2020)					
– at 20 °C, minimum,	$1,0 \times 10^{15}$	$1,0 \times 10^{15}$	$1,0 \times 10^{15}$	$1,5 \times 10^{14}$	$5,0 \times 10^{14}$
– at maximum operating temperature, minimum.	$1,0 \times 10^{12}$	$1,0 \times 10^{12}$	$1,0 \times 10^{12}$	$1,5 \times 10^{11}$	$5,0 \times 10^{11}$
Increase in AC capacity after immersion in water at 50 °C, (see 7.3 of IEC 60092-350:2020)					
– between the end of the 1 st and the end of the 14 th day, maximum (%),	15	15	–	15	15
– between the end of the 7 th and the end of the 14 th day, maximum (%).	5	5	–	5	5

4.3 Mechanical characteristics

The test requirements for mechanical characteristics of cross-linked insulating compounds are listed in Table 4.

This is a preview of "DS/IEC 60092-360:202...". Click here to purchase the full version from the ANSI store.

Table 4 – Test requirements for cross-linked elastomeric insulating compounds

Test description	Unit	Test method described in		Type of insulating compound				
		Std	Reference	EPR	HEPR	XLPE	HF 90	S 95
Mechanical properties in the state as delivered		IEC 60811-501						
Values to be obtained for the:								
– tensile strength, min.	N/mm ²			4,2	8,5	12,5	9,0	7,0
– elongation at break, min.	%			200	200	200	120	150
Mechanical properties after ageing in air oven without conductor		IEC 60811-401						
Ageing conditions:								
– temperature/ tolerance	°C			135 ± 3	135 ± 3	135 ± 3	135 ± 3	200 ± 3
– duration of treatment	h			168	168	168	168	240
Value to be obtained for the tensile strength								
– minimum value	N/mm ²			-	-	-	-	5,5
– variation max.	%			±30	±30	±25	±30	-
Value to be obtained for the elongation at break								
– minimum value	%			-	-	-	100	120
– variation max.	%			±30	±30	±25	±30	-
Mechanical properties after ageing in air oven with copper conductor		IEC 60811-401						
Ageing conditions:								
– temperature/ tolerance	°C			135 ± 3	150 ± 3			
– duration of treatment	h			168	168			
Value to be obtained for the tensile strength								
– variation max.	%			±30	±30	-		-
Value to be obtained for the elongation at break								
– variation max.	%			±30	±30	-		-
Hot set test		IEC 60811-507						
Treatment conditions:								
– temperature/ tolerance	°C			250 ± 3	250 ± 3	200 ± 3	200 ± 3	250 ± 3
– time under load min.	min			10	10	10	10	10
– mechanical stress	N/cm ²			20	20	20	20	20

This is a preview of "DS/IEC 60092-360:202...". Click here to purchase the full version from the ANSI store.

Test description	Unit	Test method described in		Type of insulating compound				
		Std	Reference	EPR	HEPR	XLPE	HF 90	S 95
Test requirements:								
– elongation max. under load	%			175	175	175	175	175
– elongation max. after unloading	%			15	15	15	15	25
Determination of hardness IRHD minimum		IEC 60092-360	Annex A		80			
Determination of elastic modulus		IEC 60092-360	Annex B					
Modulus at 150 % elongation (minimum)	N/mm ²				4,5			
Ozone resistance test (method A or B)		IEC 60811-403						
Test conditions of method A				–	–	–	–	–
– temperature	°C			25 ± 2	25 ± 2	–	25 ± 2	–
– duration	h			30	30	–	30	–
– ozone concentration	ppm			275 ± 25	275 ± 25	–	275 ± 25	–
Result to be obtained				No cracks	No cracks	–	No cracks	–
Test conditions of method B						–		–
– temperature	°C			40 ± 2	40 ± 2	–	40 ± 2	–
– duration	h			72	72	–	72	–
– ozone concentration, (by volume)	%			(200 ± 50) × 10 ⁻⁶	(200 ± 50) × 10 ⁻⁶	–	(200 ± 50) × 10 ⁻⁶	–
– relative humidity	%			55 ± 10	55 ± 10	–	55 ± 10	–
– minimum air speed at the level of the test piece	mm/s			500	500	–	500	–
Result to be obtained				No cracks	No cracks		No cracks	
Assessment of halogens ^a								
pH		IEC 60754-2		≥4,3	≥4,3	≥4,3	≥4,3	≥4,3
Conductivity	μS·mm ⁻¹			≤10	≤10	≤10	≤10	≤10
Amount of halogen acid gas:								
– HCl and HBr (max.)	%	IEC 60754-1		0,5	0,5	0,5	0,5	0,5
– HF (max.)	%	IEC 60684-2: 2011	45	0,1	0,1	0,1	0,1	0,1

^a Test required when materials are used in halogen-free cables or identified as a halogen-free compound.

This is a preview of "DS/IEC 60092-360:202...". [Click here to purchase the full version from the ANSI store.](#)

5 Cross-linked sheathing compounds

5.1 General

The types of cross-linked sheathing compound covered by this document are listed in Table 5 together with their abbreviated designations.

Table 5 – Types of cross-linked sheathing compound

Abbreviated designation	Type of material and general application
SE	Polychloroprene rubber
SH	Chlorosulphonated polyethylene or chlorinated polyethylene rubber
SHF 2	Halogen-free rubber
SE and SH materials are suitable for use over the types of insulation given in Table 2 except for XLPE. Types SE and SH are permitted even though it releases harmful fumes under fire conditions. SE and SH materials should be avoided for installation in passenger vessels and in evacuation areas.	

5.2 Mechanical characteristics

The test requirements for mechanical characteristics of cross-linked sheathing compounds are given in Table 6. Additional requirements for enhanced types are given in Clause 7. To claim enhanced performance, compounds shall comply with the relevant table or tables of Clause 7 in addition to the basic requirements in Table 6.

This is a preview of "DS/IEC 60092-360:202...". Click here to purchase the full version from the ANSI store.

Table 6 – Test requirements for cross-linked sheathing compounds

Test description	Unit	Test method described in		Type of cross-linked sheathing compound		
		Std	Clause	SH	SE	SHF 2
Mechanical properties in the state as delivered		IEC 60811-501				
Values to be obtained for: – tensile strength, min. – elongation at break, min.	N/mm ² %			10 250	10 300	9 120
Mechanical properties after ageing in air oven		IEC 60811-401				
Ageing conditions: – temperature/tolerance – duration of treatment	°C h			100 ± 2 168	100 ± 2 168	120 ± 3 168
Tensile strength – variation max.	%			±30	±30	±30
Elongation at break – value min. – variation max.	% %			±30	250 ±40	– ±30
Mechanical properties after immersion in mineral oil IRM 902		IEC 60811-404				
Ageing conditions: – temperature of oil – duration of treatment	°C h			100 ± 2 24	100 ± 2 24	100 ± 2 24
Values to be obtained for: – tensile strength, variation max. – elongation at break, variation max.	% %			±40 ±40	±40 ±40	±40 ±40
Hot set test		IEC 60811-507				
Treatment conditions: – temperature/tolerance – time under load min. – mechanical stress	°C min N/cm ²			200 ± 3 10 20	200 ± 3 10 20	– 200 ± 3 10 20
Test requirements: – elongation max. under load – elongation max. after unloading	% %			175 15	175 15	175 15

This is a preview of "DS/IEC 60092-360:202...". Click here to purchase the full version from the ANSI store.

Test description	Unit	Test method described in		Type of cross-linked sheathing compound		
		Std	Clause	SH	SE	SHF 2
Ozone resistance test (method A or B)		IEC 60811-403				
Test conditions of method A						
– temperature	°C			25 ± 2	25 ± 2	25 ± 2
– duration	h			24	24	24
– ozone concentration (by volume)	%			$(275 \pm 25) \times 10^{-4}$	$(275 \pm 25) \times 10^{-4}$	$(275 \pm 25) \times 10^{-4}$
Result to be obtained				No cracks	No cracks	No cracks
Test conditions of method B						
– temperature	°C			40 ± 2	40 ± 2	40 ± 2
– duration	h			72	72	72
– ozone concentration, (by volume)	%			$(200 \pm 50) \times 10^{-6}$	$(200 \pm 50) \times 10^{-6}$	$(200 \pm 50) \times 10^{-6}$
– relative humidity	%			55 ± 10	55 ± 10	55 ± 10
– minimum air speed at the level of the test piece	mm/s			500	500	500
Result to be obtained				No cracks	No cracks	No cracks
Behaviour at low temperature						
Elongation test (for cables not subject to bending test)		IEC 60811-505				
Test conditions:						
– temperature:	°C			-15 ± 2	-15 ± 2	-15 ± 2
– duration	h			16	16	16
Result to be obtained:						
– elongation at break, min.	%			30	30	30
Assessment of halogens ^a						
pH	-	IEC 60754-2				≥4,3
Conductivity	μS·mm ⁻¹	IEC 60754-2				≤10
Amount of halogen acid gas:						
– HCl and HBr (maximum)	%	IEC 60754-1				0,5
– HF (maximum)	%	IEC 60684-2:2011	45			0,1

^a Test required when materials used in halogen free cables or identified as halogen free compounds.

6 Thermoplastic sheathing compounds

6.1 General

The types of thermoplastic sheathing compounds covered by this document are listed in Table 7 together with their abbreviated designations.

This is a preview of "DS/IEC 60092-360:202...". Click here to purchase the full version from the ANSI store.

Table 7 – Types of thermoplastic sheathing compound

Abbreviated designation	Type of thermoplastic sheathing material
ST 2	Polyvinyl chloride thermoplastic is permitted even though it releases harmful fumes under fire conditions
SHF 1	Halogen-free thermoplastic for use over all types of insulation in Table 2
Type ST 2 is permitted even though it releases harmful fumes under fire conditions. ST 2 material should be avoided for installation in passenger vessels and in evacuation areas.	

6.2 Mechanical characteristics

The test requirements for mechanical characteristics of thermoplastic sheathing compounds are listed in Table 8.

Table 8 – Test requirements for thermoplastic sheathing compounds

Test description	Unit	Test method described in		Type of sheathing compound	
		Std	Clause	ST 2	SHF 1
Mechanical properties in the state as delivered		IEC 60811-501			
Values to be obtained for: – tensile strength, min. – elongation at break, min.	N/mm ² %			12,5 150	9,0 120
Mechanical properties after ageing in air oven without conductor		IEC 60811-401			
Ageing conditions: – temperature – duration of treatment	°C h			100 ± 2 168	100 ± 2 168
Value to be obtained for the tensile strength – minimum value – variation max.	N/mm ² %			12,5 ±25	7,0 ±30
Value to be obtained for the elongation at break – minimum value – variation max.	% %			150 ±25	110 ±30
Pressure test at high temperature		IEC 60811-508			
Test conditions: – temperature – duration for cables having an outer diameter <12,5 mm – duration for cables having an outer diameter >12,5 mm	°C h h			80 ± 2 4 6	80 ± 2 4 6
Value to be obtained: – maximum permissible deformation	%			50	50

This is a preview of "DS/IEC 60092-360:202...". Click here to purchase the full version from the ANSI store.

Test description	Unit	Test method described in		Type of sheathing compound	
		Std	Clause	ST 2	SHF 1
Heat shock		IEC 60811-509			
Test conditions:					
– temperature	°C			150 ± 3	150 ± 3
– duration	h			1	1
Result to be obtained:				No cracks	No cracks
Loss of mass		IEC 60811-409			Not applicable
Test conditions:					
– temperature	°C			100 ± 2	
– duration	h			168	
Result to be obtained:					
Maximum loss of mass	mg/cm ²			1,5	
Behaviour at low temperature					
Elongation test (for cables not subject to bending test)		IEC 60811-505			
Test conditions:					
– temperature:	°C			-15 ± 2	-15 ± 2
– duration	h			4	4
Result to be obtained:					
– elongation at break, min.	%			30	30
Assessment of halogens ^a				Not applicable	
pH		IEC 60754-2			≥4,3
Conductivity	μS·mm ⁻¹	IEC 60754-2			≤10
Amount of halogen acid gas:					
– HCl and HBr (maximum)	%	IEC 60754-1			0,5
– HF (maximum)	%	IEC 60684-2:2011	45		0,1

^a Test required when materials used in halogen free cables or identified as halogen-free compounds.

7 Additional optional properties of sheathing compounds

7.1 General

Additional optional requirements for enhanced oil resistance and drilling fluid resistance are included in Clause 7.

7.2 Test requirements

Enhanced oil resistant sheathing compounds shall comply with the tests according to Table 9.

Drilling fluid resistant sheathing compounds shall comply with the enhanced oil resistance tests according to Table 9 and to all the tests according to Table 10.

This is a preview of "DS/IEC 60092-360:202...". Click here to purchase the full version from the ANSI store.

Table 9 – Test requirements for sheathing compounds with enhanced oil resistance properties

Test description for enhanced oil resistant types	Unit	Test method described in		Requirement
		Standard	Reference	
Mechanical properties after ageing in IRM 902		IEC 60092-360	Annex C	
Test conditions: – temperature/tolerance of oil – duration of treatment	°C h			100 ± 2 168
Result to be obtained: – tensile strength, variation max. – elongation at break, variation max. – volume swell, variation max.	%			±40 ±40 ±30

Table 10 – Test requirements for sheathing compounds with drilling fluids resistance properties (test for mud resistance)

Test description for drilling fluid resistant types	Unit	Test method described in		Requirement
		Standard	Reference	
Mechanical properties after ageing in IRM 903		IEC 60092-360	Annex C	
Test conditions: – temperature/tolerance of oil – duration of treatment	°C h			100 ± 2 168
Result to be obtained: – tensile strength, variation max. – elongation at break, variation max. – volume swelling, variation max. – weight change, variation max.	% % % %			±30 ±30 ±30 ±30
Mechanical properties after ageing in calcium bromide brine		IEC 60092-360	Annex D	
Test conditions: – temperature/tolerance of fluid – duration of treatment	°C days			70 ± 2 56
Result to be obtained: – tensile strength, variation max. – elongation at break, variation max. – volume swelling, variation max. – weight change, variation max.	% % % %			±25 ±25 ±20 ±15
Mechanical properties after aging in oil based test fluid (CAS number: 64742-46-7; EC number: 934-956-3) ^a		IEC 60092-360	Annex D	
Test conditions: – temperature/tolerance of fluid – duration of treatment	°C days			70 ± 2 56
Result to be obtained: – tensile strength, variation max. – elongation at break, variation max. – volume swelling, variation max. – weight change, variation max.	% % % %			±30 ±30 ±25 ±25

^a The test fluid properties shall be according to CAS and EC numbers.

NOTE CAS (Chemical Abstracts Service) is a chemical substance category system.; EC number is a European Community unique identification of a chemical material.

This is a preview of "DS/IEC 60092-360:202...". Click here to purchase the full version from the ANSI store.

Annex A (normative)

Determination of hardness of HEPR insulation

A.1 Test piece

The test piece shall be a sample of completed cable with all the coverings external to the rubber surface to be measured carefully removed. Alternatively, a sample of insulated core may be used.

A.2 Test procedure

A.2.1 General

Tests shall be made in accordance with ISO 48-2 with exceptions as indicated in A.2.2 to A.2.5.

A.2.2 Surfaces of large radius of curvature

The test instrument, in accordance with ISO 48-2, shall be constructed so as to rest firmly on the rubber surface and permit the presser foot and indenter to make vertical contact with this surface. This is done in one of the following ways:

- a) the instrument is fitted with feet movable in universal joints so that they adjust themselves to the curved surface;
- b) the base of the instrument is fitted with two parallel rods A and A' at a distance apart depending on the curvature of the surface (see Figure A.1).

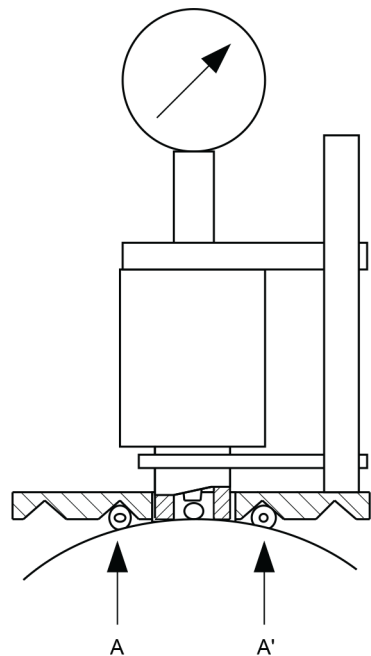

IEC

Figure A.1 – Testing surfaces of large radius of curvature

These methods may be used on surfaces with a radius of curvature down to 20 mm.

This is a preview of "DS/IEC 60092-360:202...". Click here to purchase the full version from the ANSI store.

When the thickness of rubber tested is less than 4 mm, an instrument as described in the method in ISO 48-2 for thin and small test pieces shall be used.

A.2.3 Surfaces of small radius of curvature

On surfaces with too small a radius of curvature for the procedures described in A.2.2, the test piece shall be supported on the same rigid base as the test instrument, in such a way as to minimise bodily movement of the rubber surface when the indenting force increment is applied to the indenter and so that the indenter is vertically above the axis of the test piece. Suitable procedures are as follows:

- a) by resting the test piece in a groove or trough in a metal jig – see Figure A.2 a);
- b) by resting the ends of the conductor of the test piece in V-blocks – see Figure A.2 b).

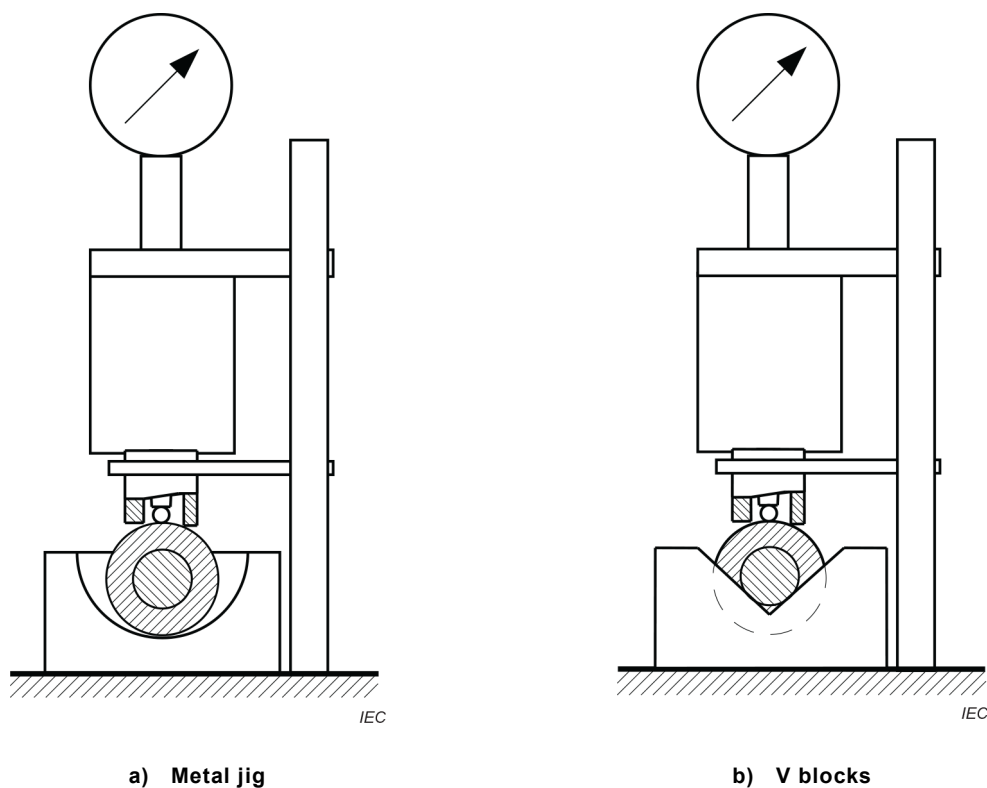

Figure A.2 – Testing surfaces of small radius of curvature

The smallest radius of curvature of the surface to be measured by these methods shall be at least 4 mm.

For smaller radii, an instrument as described in the method in ISO 48-2 for thin and small test pieces shall be used.

A.2.4 Conditioning and test temperature

The minimum time between manufacture, i.e. vulcanisation, and testing shall be 16 h.

The test shall be carried out at a temperature of $(20 \pm 2) ^\circ\text{C}$ and the test pieces shall be maintained at this temperature for at least 3 h immediately before testing.

This is a preview of "DS/IEC 60092-360:202...". [Click here to purchase the full version from the ANSI store.](#)

A.2.5 Number of measurements

One measurement shall be made at each of three or five different points distributed around the test piece. The median of the results shall be taken as the hardness of the test piece, reported to the nearest whole number in International Rubber Hardness Degrees (IRHD).

Annex B
(normative)

Determination of the elastic modulus of HEPR insulation

B.1 Procedure

Sampling, preparation of the test pieces and the test procedure shall be carried out in accordance with IEC 60811-201.

The loads required for 150 % elongation shall be measured. The corresponding stresses shall be calculated by dividing the loads measured by the cross-sectional areas of the unstretched test pieces. The ratios of the stresses to strains shall be determined to obtain the elastic modulus at 150 % elongation.

The elastic modulus shall be the respective median values.

B.2 Requirements

The results of the test shall comply with the requirements given in Table 4.

This is a preview of "DS/IEC 60092-360:202...". [Click here to purchase the full version from the ANSI store.](#)

Annex C (normative)

Procedure for enhanced hot oil immersion test for sheaths

C.1 Sampling and preparation of the test pieces

Five tests pieces shall be prepared in accordance with procedures described in 4.3 of IEC 60811-202:2012.

The test of determination of volume swell shall be carried out on dumb-bell samples of thickness $(1,25 \pm 0,25)$ mm.

C.2 Determination of the cross-sectional area of the test piece

See the test method in IEC 60811-202.

C.3 Oil to be used

Mineral oil type IRM 902 (in accordance with ISO 1817) for Table 9 or mineral oil IRM 903 (in accordance with ISO 1817) for Table 10.

C.4 Procedure

Before immersion of each test piece, the weight to within 0,1 mg and linear dimension in millimetres along the axis of the dumb-bell (to one decimal place) shall be measured at room temperature.

Then, the test pieces shall be immersed in an oil bath previously heated to (100 ± 2) °C and shall be maintained in oil at that temperature for 7 days. At the end of the specific duration, the test pieces shall be removed from the oil, blotted lightly to remove oil excess and suspended in air at ambient temperature for at least 16 h but not more than 24 h, unless otherwise specified in the relevant cable standard. At the end of this period, any further excess oil shall be removed by lightly blotting the tests pieces, and then the volume swell, weight and mechanical properties of each test piece shall be measured.

C.5 Expression of results

The calculation of tensile strength shall be based on the cross-sectional area of the test piece measured before immersion.

The difference between the median value obtained of the five test pieces immersed in oil and the median value of the values obtained for the unaged test pieces, expressed as a percentage of the latter, shall not exceed the percentage specified in the requirements.

The volume swell ΔV and change of weight ΔW are calculated as follows:

$$\Delta V = ((V_f - V_i) / V_i) \times 100$$

$$\Delta W = ((W_f - W_i) / W_i) \times 100$$

This is a preview of "DS/IEC 60092-360:202...". [Click here to purchase the full version from the ANSI store.](#)

where

V_i is the volume dimension before immersion;

V_f is the volume dimension after immersion;

W_i is the weight before immersion;

W_f is the weight after immersion.

C.6 Requirements

The results of the test shall comply with the requirements given in Table 9 or Table 10 as applicable.

This is a preview of "DS/IEC 60092-360:202...". Click here to purchase the full version from the ANSI store.

Annex D (normative)

Procedure for drilling fluid immersion test for sheaths

D.1 Drilling fluid resistance test

Drilling fluids are used in almost every oilfield drilling operation. The fluids used in the so-called drilling fluid systems may come into contact with cables and may affect the functioning of the cables. The suitability of electric cable sheathing materials, as given in this document, to exposure to these drilling fluids is heavily dependent on the type of drilling fluid present.

D.2 Test fluids

- a) Test fluids to be used for the immersion test: IRM 903 oil as given in Table 10;
- b) Generic brine-based mud (calcium bromide brine, 45 % w/w CaBr_2 in water) as given in Table 10;
- c) oil based test fluid CAS number as given in Table 10.

D.3 Procedure

Five tests pieces shall be prepared in accordance with procedures described in 4.3 of IEC 60811-202:2012.

The test for determination of volume swell is carried out on dumb-bell samples of thickness $(1,25 \pm 0,25)$ mm.

The method of the determination of the cross-sectional area of test piece is given in IEC 60811-202.

Before immersion of each test piece, the weight to within 0,1 mg and linear dimension in millimetres along the axis of the dumb-bell (to one decimal place) shall be measured at room temperature.

Then, the test pieces shall be immersed in the particular fluid as given in Table 10 previously heated to (70 ± 2) °C and shall be maintained at that temperature for 56 days. At the end of the specific duration, the test pieces shall be removed from the fluid, blotted lightly to remove excess fluid and suspended in air at ambient temperature for at least 16 h but not more than 24 h, unless otherwise specified in the relevant cable standard. At the end of this period, any further excess fluid shall be removed by lightly blotting the test pieces, and then the volume swell, weight and mechanical properties of each test piece shall be measured.

D.4 Expression of results

The calculation of tensile strength shall be based on the cross-sectional area of the test piece measured before immersion.

The difference between the median value obtained for the five test pieces immersed in fluid and the median value of the values obtained for the unaged test pieces, expressed as a percentage of the latter, shall not exceed the percentage specified in the requirements.

The volume swell ΔV and change of weight ΔW are calculated as follows:

This is a preview of "DS/IEC 60092-360:202...". Click here to purchase the full version from the ANSI store.

$$\Delta V = ((V_f - V_i) / V_i) \times 100$$

$$\Delta W = ((W_f - W_i) / W_i) \times 100$$

where

V_i is the volume dimension before immersion;

V_f is the volume dimension after immersion;

W_i is the weight before immersion ;

W_f is the weight after immersion.

D.5 Requirements

The results of the test shall comply with the requirements given in Table 10.

Materials meeting this drilling fluid resistance test are not necessarily suitable for use in a specific drilling fluid or in particular operating conditions. A specific agreement with the cable manufacturer and/or additional testing in the specific oil and particular conditions can be necessary.

This is a preview of "DS/IEC 60092-360:2021...". [Click here to purchase the full version from the ANSI store.](#)

This is a preview of "DS/IEC 60092-360:202...". Click here to purchase the full version from the ANSI store.

INTERNATIONAL
ELECTROTECHNICAL
COMMISSION

3, rue de Varembé
PO Box 131
CH-1211 Geneva 20
Switzerland

Tel: + 41 22 919 02 11
info@iec.ch
www.iec.ch