

Reaffirmed as
INCITS 489-2014 (R2019)

INCITS 489-2014

American National Standard

*for Information Technology –
SCSI over PCI Express®(SOP)*

Developed by



Where IT all begins



This is a preview of "INCITS 489-2014 (R20...)". [Click here to purchase the full version from the ANSI store.](#)

INCITS 489-2014

American National Standard
for Information Technology –
SCSI over PCI Express[®] (SOP)

Secretariat

Information Technology Industry Council

Approved June 24, 2014

American National Standards Institute, Inc.

Abstract

This standard specifies the information to be transported across PCI Express to support the services required by SAM-5 of a service delivery subsystem.

American National Standard

Approval of an American National Standard requires review by ANSI that the requirements for due process, consensus, and other criteria for approval have been met by the standards developer.

Consensus is established when, in the judgement of the ANSI Board of Standards Review, substantial agreement has been reached by directly and materially affected interests. Substantial agreement means much more than a simple majority, but not necessarily unanimity. Consensus requires that all views and objections be considered, and that a concerted effort be made towards their resolution.

The use of American National Standards is completely voluntary; their existence does not in any respect preclude anyone, whether he has approved the standards or not, from manufacturing, marketing, purchasing, or using products, processes, or procedures not conforming to the standards.

The American National Standards Institute does not develop standards and will in no circumstances give an interpretation of any American National Standard. Moreover, no person shall have the right or authority to issue an interpretation of an American National Standard in the name of the American National Standards Institute. Requests for interpretations should be addressed to the secretariat or sponsor whose name appears on the title page of this standard.

CAUTION NOTICE: This American National Standard may be revised or withdrawn at any time. The procedures of the American National Standards Institute require that action be taken periodically to reaffirm, revise, or withdraw this standard. Purchasers of American National Standards may receive current information on all standards by calling or writing the American National Standards Institute.

CAUTION: The developers of this standard have requested that holders of patents that may be required for the implementation of the standard disclose such patents to the publisher. However, neither the developers nor the publisher have undertaken a patent search in order to identify which, if any, patents may apply to this standard. As of the date of publication of this standard, following calls for the identification of patents that may be required for the implementation of the standard, notice of one or more such claims has been received. By publication of this standard, no position is taken with respect to the validity of this claim or of any rights in connection therewith. The known patent holder(s) has (have), however, filed a statement of willingness to grant a license under these rights on reasonable and nondiscriminatory terms and conditions to applicants desiring to obtain such a license. Details may be obtained from the publisher. No further patent search is conducted by the developer or publisher in respect to any standard it processes. No representation is made or implied that this is the only license that may be required to avoid infringement in the use of this standard.

Published by

**American National Standards Institute, Inc.
25 West 43rd Street, New York, NY 10036**

Copyright © 2014 by Information Technology Industry Council (ITI)
All rights reserved.

No part of this publication may be reproduced in any form, in an electronic retrieval system or otherwise, without prior written permission of ITI, 1101 K Street NW, Suite 610, Washington, DC 20005.

Printed in the United States of America

Contents

	Page
1 Scope	1
2 Normative references	2
2.1 Normative references	2
2.2 Approved references	2
2.3 References under development	2
2.4 Other references	2
3 Definitions, symbols, abbreviations, and conventions	4
3.1 Definitions	4
3.2 Symbols and abbreviations	7
3.3 Keywords	8
3.4 Editorial conventions	9
3.5 Numeric and character conventions	10
3.5.1 Numeric conventions	10
3.5.2 Byte encoded character strings conventions	10
3.6 Bit and byte ordering	11
3.7 Notation for procedure calls	13
3.8 UML notation convention	13
3.8.1 UML notation convention overview	13
3.8.2 Constraint and note conventions	14
3.8.3 Class diagram conventions	15
3.8.4 Object diagram conventions	20
4 General	21
4.1 PCI Express configuration	21
4.2 PCI Express queuing layer services	21
4.3 SOP classes	22
4.3.1 SOP classes overview	22
4.3.2 SOP Domain class	24
4.3.2.1 SOP Domain class overview	24
4.3.2.2 SOP Service Delivery Subsystem class	24
4.3.2.2.1 SOP Service Delivery Subsystem class overview	24
4.3.2.2.2 PCI Express Fabric class	25
4.3.2.2.3 Queue Structure class	25
4.3.2.2.4 Inbound Queue class	25
4.3.2.2.5 Outbound Queue class	25
4.3.2.3 SOP Device class	25
4.3.2.4 SOP Initiator Device class	27
4.3.2.5 SOP Management Application Client class	27
4.3.2.5.1 SOP Management Application Client class overview	27
4.3.2.5.2 Received SOP Management Function Executed operation	28
4.3.2.5.3 Nexus Loss operation	28
4.3.2.5.4 Transport Reset operation	28
4.3.2.6 SOP SCSI Application client class	28
4.3.2.6.1 SOP SCSI Application client class overview	28
4.3.2.6.2 Command Complete Received operation	28
4.3.2.6.3 Received Task Management Function Executed operation	28
4.3.2.6.4 Nexus Loss operation	28
4.3.2.6.5 Transport Reset operation	28
4.3.2.7 SOP Target Device class	28
4.3.2.8 SOP Management Device Server class	29

4.3.2.8.1 SOP Management Device Server class overview	29
4.3.2.8.2 SOP Management Function Received operation	29
4.3.2.9 SOP Port class	29
4.3.2.9.1 SOP Port class overview	29
4.3.2.9.2 Relative Port Identifier attribute	29
4.3.2.9.3 SOP Initiator Port class	30
4.3.2.9.3.1 SOP Initiator Port class overview	30
4.3.2.9.3.2 Send SCSI Command operation	30
4.3.2.9.3.3 Send Task Management Request operation	30
4.3.2.9.3.4 Send SOP Management Request operation	31
4.3.2.9.3.5 Outbound IU Received operation	31
4.3.2.9.4 Host Queuing Interface class	31
4.3.2.9.4.1 Host Queuing Interface class overview	31
4.3.2.9.4.2 Routing ID attribute	31
4.3.2.9.4.3 Add To Inbound Queue operation	31
4.3.2.9.5 SOP Target Port class	31
4.3.2.9.5.1 SOP Target Port class overview	31
4.3.2.9.5.2 Send Data-In operation	32
4.3.2.9.5.3 Receive Data-Out operation	32
4.3.2.9.5.4 Terminate Data Transfer operation	33
4.3.2.9.5.5 Send Command Complete operation	33
4.3.2.9.5.6 Task Management Function Executed operation	33
4.3.2.9.5.7 SOP Management Function Executed operation	33
4.3.2.9.5.8 Inbound IU Received operation	33
4.3.2.9.6 Device Queuing Interface class	33
4.3.2.9.6.1 Device Queuing Interface class overview	33
4.3.2.9.6.2 Routing ID attribute	33
4.3.2.9.6.3 Add To Outbound Queue operation	33
4.3.2.10 SOP Task Router class	34
4.3.2.10.1 SOP Task Router class overview	34
4.3.2.10.2 Route Command operation	34
4.3.2.10.3 Route Task Management Function operation	34
4.3.2.11 Bridge class	34
4.3.2.11.1 Bridge class overview	34
4.3.2.11.2 Bridge Application Client class	36
4.3.2.11.2.1 Bridge Application Client class overview	36
4.3.2.11.2.2 Forward SCSI Command operation	36
4.3.2.11.2.3 Forward Task Management Request operation	36
4.3.2.11.2.4 Command Complete Received operation	36
4.3.2.11.2.5 Received Task Management Function Executed operation	36
4.3.2.11.2.6 Nexus Loss operation	36
4.3.2.11.2.7 Transport Reset operation	36
4.3.2.11.3 Bridge Task Manager class	36
4.3.2.11.3.1 Bridge Task Manager class overview	36
4.3.2.11.3.2 SCSI Command Received operation	36
4.3.2.11.3.3 Task Management Request Received operation	37
4.3.2.11.3.4 Data Transfer Terminated operation	37
4.3.2.11.3.5 Forward Task Management Function Executed operation	37
4.3.2.11.3.6 Nexus Loss operation	37
4.3.2.11.3.7 Transport Reset operation	37
4.3.2.11.3.8 Power Loss Expected operation	37
4.3.2.11.4 Bridge Device Server class	37
4.3.2.11.4.1 Bridge Device Server class overview	37
4.3.2.11.4.2 Data-In Delivered operation	37
4.3.2.11.4.3 Data-Out Received operation	37
4.3.2.11.4.4 Data Transfer Terminated operation	38
4.3.2.11.4.5 Forward Command Complete operation	38

4.3.2.11.4.6 Nexus Loss operation	38
4.3.2.11.4.7 Transport Reset operation	38
4.3.2.11.4.8 Power Loss Expected operation	38
4.3.2.11.4.9 SCSI Initiator Port class	38
4.3.2.12 SOP domain example	39
4.4 Names and identifiers	40
4.4.1 Names and identifiers overview	40
4.4.2 PCI Express IDs	42
4.4.3 NAA IEEE Registered format identifier	42
4.4.4 NAA Locally Assigned format identifier	42
4.4.5 Device names	43
4.4.6 SOP target port names	43
4.4.7 SOP target port identifiers	43
4.4.8 Routing ID	43
4.4.9 Nexus Identifiers	44
4.5 Bridge	44
4.5.1 Bridge overview	44
4.5.2 Nexus identifiers for bridges	46
4.5.3 Nexus generation count	46
4.5.4 Forwarding by a bridge	47
4.5.5 SCSI Command Received to Send SCSI Command mapping	49
4.5.6 Command Complete Received to Send Command Complete mapping	51
4.5.7 Task Management Request Received to Send Task Management Request mapping	53
4.5.8 Received Task Management Function Executed to Task Management Function Executed mapping	55
4.5.9 Request identifier and outbound queue identifier mapping	56
4.6 Data transfers	56
4.7 Request identifier	57
4.8 SCSI events	57
4.8.1 Hard reset	57
4.8.2 I_T nexus loss	58
4.8.3 Power loss expected	58
4.9 Fencing	58
4.9.1 Fencing overview	58
4.9.2 Sending a request IU for a fencing command or fencing task management function	59
4.9.3 Processing a fencing command or a fencing task management function	59
4.9.4 Processing a response IU for a fencing command or fencing task management function	60
4.10 Asynchronous events	60
4.10.1 Asynchronous events overview	60
4.10.2 INBOUND QUEUE ERROR event type	62
4.10.3 NEXUS IDENTIFIER INVENTORY HAS CHANGED event type	63
4.10.4 BRIDGE LOCAL PORT DETECTED ERROR event type	64
4.11 Parameter rounding	64
5 SOP information unit layer	65
5.1 SOP information unit layer overview	65
5.2 SOP IU definitions	65
5.2.1 SOP IU definitions overview	65
5.2.2 IU header	67
5.2.3 NULL IU	69
5.2.4 General management request IUs	70
5.2.4.1 REPORT GENERAL IU	70
5.2.4.1.1 REPORT GENERAL IU overview	70
5.2.4.1.2 REPORT GENERAL parameter data	71
5.2.4.2 REPORT EVENT CONFIGURATION IU	73
5.2.4.2.1 REPORT EVENT CONFIGURATION IU overview	73
5.2.4.2.2 REPORT EVENT CONFIGURATION Data-In Buffer contents	74
5.2.4.3 SET EVENT CONFIGURATION IU	75

5.2.4.3.1 SET EVENT CONFIGURATION IU overview	75
5.2.4.3.2 SET EVENT CONFIGURATION parameter list	77
5.2.5 SCSI request IUs	79
5.2.5.1 LIMITED COMMAND IU	79
5.2.5.2 COMMAND IU	81
5.2.5.3 EXTENDED COMMAND IU	85
5.2.5.4 TASK MANAGEMENT IU	89
5.2.6 Bridge management request IUs	92
5.2.6.1 REPORT BRIDGE LOCAL PORTS IU	92
5.2.6.1.1 REPORT BRIDGE LOCAL PORTS IU overview	92
5.2.6.1.2 REPORT BRIDGE LOCAL PORTS parameter data	93
5.2.6.2 REPORT BRIDGE LOCAL PORT DETAILS IU	95
5.2.6.2.1 REPORT BRIDGE LOCAL PORT DETAILS IU overview	95
5.2.6.2.2 REPORT BRIDGE LOCAL PORT DETAILS parameter data	97
5.2.6.3 REPORT BRIDGE NEXUSES IU	99
5.2.6.3.1 REPORT BRIDGE NEXUSES IU overview	99
5.2.6.3.2 REPORT BRIDGE NEXUSES parameter data	100
5.2.6.4 REPORT BRIDGE NEXUS DETAILS IU	102
5.2.6.4.1 REPORT BRIDGE NEXUS DETAILS IU overview	102
5.2.6.4.2 REPORT BRIDGE NEXUS DETAILS parameter data	103
5.2.6.5 REMOVE BRIDGE NEXUS IU	104
5.2.7 General response IUs	105
5.2.7.1 MANAGEMENT RESPONSE IU	105
5.2.7.1.1 MANAGEMENT RESPONSE IU overview	105
5.2.7.1.2 Result specific data for INVALID FIELD IN REQUEST IU	107
5.2.7.1.3 Result specific data for INVALID FIELD IN DATA-OUT BUFFER	107
5.2.7.2 EVENT IU	108
5.2.7.3 EVENT ACKNOWLEDGE IU	109
5.2.8 SCSI command response IUs	109
5.2.8.1 SUCCESS IU	109
5.2.8.2 COMMAND RESPONSE IU	111
5.2.8.2.1 COMMAND RESPONSE IU overview	111
5.2.8.2.2 No sense data and no response data	116
5.2.8.2.3 Sense data present	116
5.2.8.2.4 Response data present	116
5.2.8.3 TASK MANAGEMENT RESPONSE IU	118
5.3 SOP sequences for SCSI commands and task management functions	118
5.3.1 SOP sequences for SCSI commands and task management functions overview	118
5.3.2 Task management function sequence	119
5.3.3 Non-data command sequence	119
5.3.4 Read command sequence	120
5.3.5 Write command sequence	120
5.3.6 Bidirectional command sequence	122
6 Application layer	123
6.1 Application layer overview	123
6.2 SCSI transport protocol services	124
6.2.1 SCSI transport protocol services for SCSI commands	124
6.2.1.1 SCSI transport protocol services for SCSI commands overview	124
6.2.1.2 Send SCSI Command transport protocol service request	125
6.2.1.3 SCSI Command Received transport protocol service indication	126
6.2.1.4 Send Command Complete transport protocol service response	128
6.2.1.5 Command Complete Received transport protocol service confirmation	131
6.2.1.6 Send Data-In transport protocol service request	132
6.2.1.7 Data-In Delivered transport protocol service confirmation	134
6.2.1.8 Receive Data-Out transport protocol service request	134
6.2.1.9 Data-Out Received transport protocol service confirmation	135

6.2.1.10 Terminate Data Transfer transport protocol service request	136
6.2.1.11 Data Transfer Terminated transport protocol service confirmation	136
6.2.2 SCSI transport protocol services for task management functions	137
6.2.2.1 SCSI transport protocol services for task management functions overview	137
6.2.2.2 Send Task Management Request transport protocol service request	138
6.2.2.3 Task Management Request Received SCSI transport protocol service indication	140
6.2.2.4 Task Management Function Executed SCSI transport protocol service response	142
6.2.2.5 Received Task Management Function Executed transport protocol service confirmation	144
6.2.3 SCSI transport protocol services for event notification	145
6.2.3.1 Transport Reset transport protocol service indication	145
6.2.3.2 Nexus Loss transport protocol service indication	146
6.2.3.3 Power Loss Expected transport protocol service indication	146
6.3 Task router and task manager error handling	147
6.3.1 Request identifier overlap handling summary	147
6.3.2 SCSI command overlap with SCSI command	147
6.3.3 SCSI command overlap with task management function or SOP management function	147
6.3.4 Task management function overlap	148
6.3.5 SOP management function overlap	148
6.4 Device server error handling	149
6.4.1 Device server Data-In Buffer error handling	149
6.4.2 Device server Data-Out Buffer error handling	150
6.5 SCSI commands	151
6.5.1 INQUIRY command	151
6.5.2 MODE SELECT and MODE SENSE commands	151
6.6 SCSI mode parameters	151
6.6.1 SCSI mode parameters overview	151
6.6.2 Protocol-Specific Logical Unit mode page	152
6.6.3 Protocol-Specific Port mode page	152
6.7 SCSI vital product data (VPD)	153
6.7.1 SCSI vital product data (VPD) overview	153
6.7.2 Device Identification VPD page	153
Annex A (normative) Mapping SOP over PQI.....	156
A.1 SOP classes for PQI	156
A.1.1 SOP classes mapping to PQI classes	156
A.1.2 SOP Domain class for PQI	157
A.1.3 Host Queuing Interface class for PQI	157
A.1.3.1 Host Queuing Interface class for PQI overview	157
A.1.3.2 Add To Inbound Queue operation	158
A.1.4 Device Queuing Interface class for PQI	158
A.1.4.1 Device Queuing Interface class for PQI overview	158
A.1.4.2 Add To Outbound Queue operation	159
A.2 Support requirements for the SGL descriptor types for SOP IUs	160
A.3 PQI specific SOP IU fields	160
A.3.1 QISEOQ field and GQISEOQ field	160
A.3.2 QUEUING INTERFACE SPECIFIC field for request IUs	161
A.3.3 QUEUING INTERFACE SPECIFIC field for response IUs	161
A.3.3.1 queuing interface specific field for response IUs overview	161
A.3.3.2 Outbound queue to manage	161
A.3.4 Data-In Buffer descriptor area	162
A.3.5 Data-Out Buffer descriptor area	162
A.3.6 Data Buffer descriptor area	162
A.3.7 DATA-IN BUFFER DESCRIPTOR AREA LENGTH field	162
A.4 Queuing layer reset events	162
A.5 Queuing layer I_T nexus loss events	163
A.6 REPORT GENERAL queuing interface specific general data for PQI	163
A.7 Queuing layer specific inbound queue error information descriptor for PQI	164

A.8 SGL error handling	164
Annex B (normative) Protocol specific requirements for bridges	165
B.1 Request identifiers	165
B.1.1 Request identifier and outbound queue identifier mapping	165
B.1.2 Protocol specific bridge forwarding examples	166
B.2 Event information for the BRIDGE LOCAL PORT DETECTED ERROR event type	171
B.2.1 Event information for the BRIDGE LOCAL PORT DETECTED ERROR event type overview	171
B.2.2 Event information for a SAS SSP local port	172
B.3 PROTOCOL SPECIFIC field	175
B.3.1 PROTOCOL SPECIFIC field overview	175
B.3.2 FCP	175
B.3.3 SAS SSP	176
B.4 Bridge port identifiers	176
B.4.1 Bridge port identifiers overview	176
B.4.2 FCP bridge port identifier	177
B.4.3 SRP bridge port identifier	177
B.4.4 iSCSI bridge port identifier	178
B.4.5 SAS SSP bridge port identifier	180
B.4.6 UAS bridge port identifier	180
B.4.7 SOP bridge port identifier	180
B.5 Data Buffer overflow mapping	181
B.6 Additional response information	182
B.6.1 Additional response information overview	182
B.6.2 Additional response information for a SAS SSP local port	182

Tables

	Page
Table 1 — Numbering conventions	10
Table 2 — Example of a 32-bit big-endian field	11
Table 3 — Bit assignments in a 32-bit big-endian field	12
Table 4 — Example of a 32-bit little-endian field	12
Table 5 — Bit numbers for a 32-bit little-endian field	12
Table 6 — Constraint and note notation	14
Table 7 — Class diagram notation for classes	15
Table 8 — Multiplicity notation	16
Table 9 — Class diagram notation for associations	16
Table 10 — Class diagram notation for aggregations	17
Table 11 — Class diagram notation for generalizations	18
Table 12 — Class diagram notation for dependency	19
Table 13 — Object diagram notation for objects	20
Table 14 — Object diagram notation for link	20
Table 15 — Attribute mapping	41
Table 16 — SAM-5 attribute mapping	41
Table 17 — NAA IEEE Registered format	42
Table 18 — NAA Locally Assigned format	42
Table 19 — Routing ID for a PCI Express device without alternative routing ID Interpretation	43
Table 20 — Routing ID for a PCI Express device with alternative routing ID Interpretation	43
Table 21 — Execute Command procedure call mapping by a bridge	47
Table 22 — SCSI Command Received to Forward SCSI Command argument mapping	49
Table 23 — Forward SCSI Command to Send SCSI Command argument mapping	50
Table 24 — Command Complete Received to Forward Command Complete argument mapping	51
Table 25 — Forward Command Complete to Send Command Complete argument mapping	52
Table 26 — Task Management Request Received to Forward Task Management Request argument map	53
Table 27 — Forward Task Management Request to Send Task Management Request argument map	54
Table 28 — Received Task Management Function Executed to Forward Task Management Function Executed argument map	55
Table 29 — Forward Task Management Function Executed to Task Management Function Executed argument map	56
Table 30 — Event types	61
Table 31 — EVENT IDENTIFIER field for the INBOUND QUEUE ERROR event type	62
Table 32 — ADDITIONAL EVENT IDENTIFIER field for the INBOUND QUEUE ERROR event type	62
Table 33 — Event data for the INBOUND QUEUE ERROR event type	63
Table 34 — EVENT IDENTIFIER field for the NEXUS IDENTIFIER INVENTORY HAS CHANGED event type	63
Table 35 — ADDITIONAL EVENT IDENTIFIER field for the NEXUS IDENTIFIER INVENTORY HAS CHANGED event type	64
Table 36 — SOP IU types	65
Table 37 — IU header	67
Table 38 — IU header error handling	68
Table 39 — NULL IU	69
Table 40 — REPORT GENERAL IU	70
Table 41 — REPORT GENERAL parameter data	71
Table 42 — REPORT EVENT CONFIGURATION IU	73
Table 43 — REPORT EVENT CONFIGURATION parameter Data-In Buffer	74
Table 44 — Report event configuration descriptor	75
Table 45 — SET EVENT CONFIGURATION IU	75
Table 46 — SET EVENT CONFIGURATION parameter list (i.e., Data-Out buffer contents)	77
Table 47 — Set event configuration descriptor	78
Table 48 — QGISEOQ field and the QISEOQ field	78
Table 49 — LIMITED COMMAND IU	80
Table 50 — DATA DIRECTION field	81

Table 51 — COMMAND IU	82
Table 52 — TASK ATTRIBUTE field	84
Table 53 — ADDITIONAL CDB BYTES USAGE field	84
Table 54 — EXTENDED COMMAND IU	85
Table 55 — DATA DIRECTION field	87
Table 56 — TASK MANAGEMENT IU	89
Table 57 — TASK MANAGEMENT FUNCTION field	90
Table 58 — REPORT BRIDGE LOCAL PORTS IU	92
Table 59 — REPORT BRIDGE LOCAL PORTS parameter Data-In Buffer	93
Table 60 — Local port descriptor	94
Table 61 — REPORT BRIDGE LOCAL PORT DETAILS IU	95
Table 62 — REPORT BRIDGE LOCAL PORT DETAILS parameter Data-In Buffer	97
Table 63 — REPORT BRIDGE NEXUSES IU	99
Table 64 — REPORT BRIDGE NEXUSES parameter Data-In Buffer	100
Table 65 — Nexus descriptor	100
Table 66 — REPORT BRIDGE NEXUS DETAILS IU	102
Table 67 — REPORT BRIDGE NEXUS DETAILS parameter Data-In Buffer	103
Table 68 — REMOVE BRIDGE NEXUS IU	104
Table 69 — MANAGEMENT RESPONSE IU	105
Table 70 — RESULT field	106
Table 71 — Result specific data for RESULT field set to INVALID FIELD IN REQUEST IU	107
Table 72 — Result specific data for RESULT field set to INVALID FIELD IN DATA-OUT BUFFER	107
Table 73 — EVENT IU	108
Table 74 — EVENT ACKNOWLEDGE IU	109
Table 75 — SUCCESS IU	110
Table 76 — COMMAND RESPONSE IU	111
Table 77 — DATA-IN TRANSFER RESULT field and the DATA-IN TRANSFERRED field	113
Table 78 — DATA-OUT TRANSFER RESULT field and the DATA-OUT TRANSFERRED field	114
Table 79 — SENSE DATA LENGTH field and RESPONSE DATA LENGTH field combinations	115
Table 80 — RESPONSE DATA field	116
Table 81 — RESPONSE CODE field	117
Table 82 — TASK MANAGEMENT RESPONSE IU	118
Table 83 — Sequences of SOP communications	119
Table 84 — Execute Command procedure call transport protocol services	124
Table 85 — Send SCSI Command operation argument usage	125
Table 86 — SCSI Command Received operation argument sources	127
Table 87 — Send Command Complete operation argument usage	129
Table 88 — Command Complete Received operation argument sources	131
Table 89 — Send Data-In operation argument usage	133
Table 90 — Data-In Delivered operation argument sources	134
Table 91 — Receive Data-Out operation argument usage	134
Table 92 — Data-Out Received operation argument sources	135
Table 93 — Terminate Data Transfer operation argument usage	136
Table 94 — Data Transfer Terminated operation argument sources	136
Table 95 — Task management function procedure call transport protocol services	137
Table 96 — Send Task Management Request operation argument usage	139
Table 97 — Task Management Request Received operation argument sources	141
Table 98 — Task Management Function Executed operation argument usage	142
Table 99 — Received Task Management Function Executed operation argument sources	144
Table 100 — Transport Reset operation arguments	146
Table 101 — Request identifier overlap handling summary	147
Table 102 — Data-In Delivered Delivery Result of DELIVERY FAILURE handling	149
Table 103 — Data-Out Received Delivery Result of DELIVERY FAILURE handling	150
Table 104 — SOP target port mode pages	151
Table 105 — Protocol-Specific Logical Unit mode page for SOP	152
Table 106 — Protocol-Specific Port mode page for SOP	153
Table 107 — Device Identification VPD page designation descriptors for a SOP target port	153

Table 108 — Device Identification VPD page designation descriptors for a SOP target port	154
Table 109 — Device Identification VPD page designation descriptors for a SOP target device	155
Table A.1 — Support requirements for the SGL descriptor types for SOP IUs	160
Table A.2 — QISEOQ field and GQISEOQ field	160
Table A.3 — QUEUING INTERFACE SPECIFIC REQUEST field definition for a request IU for PQI	161
Table A.4 — QUEUING INTERFACE SPECIFIC field definition for a response IU for PQI	161
Table A.5 — OUTBOUND QUEUE TO MANAGE field for PQI	162
Table A.6 — REPORT GENERAL Queuing interface specific general data for PQI	163
Table A.7 — Queuing layer specific inbound queue error information descriptor for PQI	164
Table B.1 — Request identifier mapping	165
Table B.2 — Forwarding by a bridge to a local port that is an FCP port	166
Table B.3 — Forwarding by a bridge to a local port that is an SRP port	167
Table B.4 — Forwarding by a bridge to a local port that is an iSCSI port	168
Table B.5 — Forwarding by a bridge to a local port that is an SAS SSP port	169
Table B.6 — Forwarding by a bridge to a local port that is a UAS USB-2 port	170
Table B.7 — Forwarding by a bridge to a local port that is a UAS USB-3 port	171
Table B.8 — Event information returned by a bridge	171
Table B.9 — Bridge local port detected error events for SAS SSP	172
Table B.10 — Bridge local port detected error event for SAS SSP	173
Table B.11 — Event data for bridge local port detected error events for SAS SSP	174
Table B.12 — Forwarding by a bridge to a local port that is a SOP port	174
Table B.13 — PROTOCOL SPECIFIC field	175
Table B.14 — PROTOCOL SPECIFIC field for FCP	175
Table B.15 — PROTOCOL SPECIFIC field for SAS SSP	176
Table B.16 — Bridge port identifiers	176
Table B.17 — Bridge port identifier for FCP	177
Table B.18 — Bridge port identifier for SRP	177
Table B.19 — Bridge port identifier for iSCSI	178
Table B.20 — Bridge port identifier for SAS SSP	180
Table B.21 — Bridge port identifier for UAS	180
Table B.22 — Bridge port identifier for SOP	180
Table B.23 — Data-In Buffer overflow and Data-Out Buffer overflow detection	181
Table B.24 — Additional response information returned by a bridge	182
Table B.25 — Bridge local port detected error responses for SAS SSP	182
Table B.26 — SAS ERROR RESPONSE field	182

Figures

	Page
Figure 1 — SCSI document relationships	1
Figure 2 — Examples of association relationships in class diagrams	17
Figure 3 — Examples of aggregation relationships in class diagrams	18
Figure 4 — Example of generalization relationships in class diagrams	19
Figure 5 — Example of a dependency relationship in class diagrams	19
Figure 6 — Examples of link relationships for object diagrams	20
Figure 7 — SOP Domain class diagram overview	22
Figure 8 — Relationship between SOP classes and SCSI classes	23
Figure 9 — SOP Domain class diagram	24
Figure 10 — SOP Service Delivery Subsystem class diagram	25
Figure 11 — SOP Initiator Device class diagram	27
Figure 12 — SOP Target Device class diagram	29
Figure 13 — SOP Initiator Port class diagram	30
Figure 14 — SOP Target Port class diagram	32
Figure 15 — Bridge class diagram	35
Figure 16 — SOP domain example	39
Figure 17 — UML instantiation of SOP domain example	40
Figure 18 — Example where a SOP device contains a bridge	45
Figure 19 — Task management function sequence	119
Figure 20 — Non-data command sequence	120
Figure 21 — Read command sequence	120
Figure 22 — Write command sequence	121
Figure 23 — Bidirectional command sequence	122
Figure A.1 — SOP classes mapping to PQI classes	156

Foreword (This foreword is not part of American National Standard INCITS 489-2014.)

This standard defines a SCSI transport protocol for a PCI Express queuing interface. This standard may be used in conjunction with the PCI Express Queuing Interface (PQI) standard. This ensures that investments in such solutions have a stable and managed migration path as technologies continue to evolve and expand.

Requests for interpretation, suggestions for improvement and addenda, or defect reports are welcome. They should be sent to the INCITS Secretariat, International Committee for Information Technology Standards, Information Technology Industry Council, Suite 610, 1101 K Street, NW, Washington, DC 20005.

This standard was processed and approved for submittal to ANSI by the International Committee for Information Technology Standards (INCITS). Committee approval of the standard does not necessarily imply that all committee members voted for its approval. At the time it approved this standard, INCITS had the following members:

Philip Wennblom, Chair
Jennifer Garner, Secretary

<i>Organization Represented</i>	<i>Name of Representative</i>
Adobe Systems Inc.....	Scott Foshee Steve Zilles (Alt.)
AIM Global, Inc.	Steve Halliday Chuck Evanhoe (Alt.) Dan Kimball (Alt.)
Apple	Helene Workman Marc Braner (Alt.) David Singer (Alt.)
Distributed Management Task Force	John Crandall Jeff Hilland (Alt.) Lawrence Lamers (Alt.)
EMC Corporation	Gary Robinson Stephen Diamond (Alt.)
Farance, Inc.....	Frank Farance Timothy Schoechle (Alt.)
Futurewei Technologies, Inc.....	Yi Zhao Timothy Jeffries (Alt.) Wilbert Adams (Alt.)
GS1GO.....	Frank Sharkey Charles Biss (Alt.)
Hewlett-Packard Company	Karen Higginbottom Paul Jeran (Alt.)
IBM Corporation	Alexander Tarpinian Robert Weir (Alt.) Arnaud Le Hors (Alt.) Steve Holbrook (Alt.) Gerald Lane (Alt.)
IEEE	Jodi Haasz Terry deCourcelle (Alt.) Bob Labelle (Alt.) Tina Alston (Alt.)
Intel	Philip Wennblom Grace Wei (Alt.) Steven Balogh (Alt.)
Microsoft Corporation	Jim Hughes Dick Brackney (Alt.) John Calhoon (Alt.)

<i>Organization Represented</i>	<i>Name of Representative</i>
National Institute of Standards & Technology	Michael Hogan Sal Francomacaro (Alt.) Dan Benigni (Alt.) Fernando Podio (Alt.) Teresa Schwartzhoff (Alt.) Wo Chang (Alt.) Elaine Newton (Alt.)
Oracle Corporation	Donald R. Deutsch Jim Melton (Alt.) Michael Kavanaugh (Alt.) Toshihiro Suzuki (Alt.) Jeff Mischkinsky (Alt.) Tony DiCenzo (Alt.) Patrick Curran (Alt.)
Purdue University	Stephen Elliott Kevin O'Connor (Alt.)
Telecommunications Industry Association (TIA)	Herb Congdon, II Cheryl Blum (Alt.) Florence Otieno (Alt.)
US Department of Defense	Jerry Smith Dennis Devera (Alt.) Dave Brown (Alt.) Leonard Levine (Alt.) Matthew Young (Alt.) Thomas D'Agostino (Alt.)
US Department of Homeland Security	Peter Shebell Gregg Piermarini (Alt.) Juan Gonzalez (Alt.)

INCITS Technical Committee T10 on SCSI Storage Interfaces, which developed and reviewed this standard, had the following members:

John B. Lohmeyer, Chair
Bill Martin, Vice-Chair
Ralph O. Weber, Secretary

<i>Organization Represented</i>	<i>Name of Representative</i>
Amphenol Corporation.....	Gregory McSorley David Chan (Alt.) Paul Coddington (Alt.) Zhineng Fan (Alt.) Adrian Green (Alt.) Simon Hui (Alt.) Martin Li (Alt.) Alex Persaud (Alt.) Chansy Phommachanh (Alt.) Michael Wingard (Alt.) CN Wong (Alt.) Matt Wright (Alt.)
Bellwether Electronic Corporation	Chris Schmolze Larry Hsu (Alt.)
Brocade	David Peterson Scott Kipp (Alt.)
Dell, Inc.....	Kevin Marks Mark Bokhan (Alt.) Janet Long (Alt.) Bill Lynn (Alt.) Ash McCarty (Alt.) Daniel Oelke (Alt.) Daniel Suman (Alt.) Han Wang (Alt.)
EMC Corporation.....	Gary Robinson David Black (Alt.) Mickey Felton (Alt.) Marlon Ramroopsingh (Alt.)

<i>Organization Represented</i>	<i>Name of Representative</i>
FCI Electronics	Donald Harper Paul Rubens (Alt.) Dave Sideck (Alt.)
Foxconn Electronics	Fred Fons Gary Hsieh (Alt.) Glenn Moore (Alt.) Mike Shu (Alt.) Miller Zhao (Alt.)
Fujitsu America, Inc.	Kun Katsumata Jim DeCaires (Alt.) Osamu Kimura (Alt.) Mark Malcolm (Alt.) Gene Owens (Alt.) Sandy Wilson (Alt.)
Fusion-io	Walt Hubis Bob Wood (Alt.)
Futurewei Technologies, Inc.	Serge Manning Xiaoyu Ge (Alt.) Xiaoyan He (Alt.) Alan Yoder (Alt.) HengLiang Zhang (Alt.)
Hewlett-Packard Company	Curtis Ballard Wayne Bellamy (Alt.) Rob Elliott (Alt.) Steven Fairchild (Alt.) Joe Foster (Alt.) Barry Olawsky (Alt.) Jeff Wolford (Alt.)
HGST	Frank Chu David Brewer (Alt.) Chet Mercado (Alt.) Nadesan Narenthiran (Alt.)
IBM Corporation	Kevin Butt Mark Andresen (Alt.) Mike Osborne (Alt.) Ted Vojnovich (Alt.)
Intel Corporation	Pak-Lung Seto Richard Mellitz (Alt.) Mark Seidel (Alt.)
JDS Uniphase Corporation	David Freeman George Bullis (Alt.) Dominic Coupal (Alt.) Gerard Geary (Alt.) Paul Gentieu (Alt.) Geoff Hibbert (Alt.) Francisco Roy (Alt.) Yamini Shastry (Alt.)
KnowledgeTek, Inc.	Dennis Moore Hugh Curley (Alt.)
LSI Corporation	John Lohmeyer Patrick Bashford (Alt.) Brad Besmer (Alt.) Srikiran Dravida (Alt.) Steve Johnson (Alt.) Bernhard Laschinsky (Alt.) Parag Maharana (Alt.) Harvey Newman (Alt.) George Penokie (Alt.) Sumit Puri (Alt.) Robert Sheffield (Alt.) Ross Stenfort (Alt.) Bill Voorhees (Alt.)
Marvell Semiconductor, Inc.	David Geddes Paul Wassenberg (Alt.)

<i>Organization Represented</i>	<i>Name of Representative</i>
Micron Technology, Inc.	John Geldman Jerry Barkley (Alt.) Neal Galbo (Alt.) Michael George (Alt.) Alan Haffner (Alt.) Randy Matthews (Alt.) Niels Reimers (Alt.) Bob Warren (Alt.)
Microsoft Corporation	Calvin Chen Paul Luber (Alt.) Bryan Matthew (Alt.) Steve Olsson (Alt.)
Molex, Inc.	Jay Neer Michael Rost (Alt.) Darian Schulz (Alt.)
NetApp, Inc.	Frederick Knight Chris Fore (Alt.) Jaimon George (Alt.) Subhash Sankuratripati (Alt.) Ali Yavari (Alt.)
Oracle	Dennis Appleyard Jon Allen (Alt.) Martin Faltese (Alt.) Seth Goldberg (Alt.) Martin Petersen (Alt.) Wan Shan (Alt.) Phi Tran (Alt.) Lee Wan-Hui (Alt.)
PMC-Sierra	Tim Symons David Allen (Alt.) Paul Borsetti (Alt.) Graeme Boyd (Alt.) Steve Gerson (Alt.) Bill Lye (Alt.) Ie-Wei Njoo (Alt.) Keith Shaw (Alt.) Gregory Tabor (Alt.) Neil Wanamaker (Alt.) Rod Zavari (Alt.)
Quantum Corporation	Paul Suhler Paul Stone (Alt.) Rod Wideman (Alt.)
Samsung Semiconductor, Inc. (SSI)	William Martin Judy Brock (Alt.) Edward Chang (Alt.) HeeChang Cho (Alt.) KeunSoo Jo (Alt.) ByeungJun Lee (Alt.) Jake Lee (Alt.) Sung Lee (Alt.) Bhavith M.P. (Alt.) Truong Nguyen (Alt.) Dmitry Obukhov (Alt.) Changhyun Park (Alt.) Santosh Singh (Alt.)
SanDisk IL, Ltd.	Avraham Shimor Dave Landsman (Alt.) Yoni Shternhell (Alt.)
Seagate Technology	Gerald Houlder Alvin Cox (Alt.) Jim Hatfield (Alt.) Judy Westby (Alt.)
Synapse Design Automation	Joe Breher

<i>Organization Represented</i>	<i>Name of Representative</i>
TE Connectivity	Dan Gorenc Mike Davis (Alt.) Michael Fogg (Alt.) Tom Grzysiewicz (Alt.) John Hackman (Alt.) Doron Lapidot (Alt.) Joel Meyers (Alt.) Andy Nowak (Alt.) Eric Powell (Alt.) Yasuo Sasaki (Alt.) Scott Shuey (Alt.) Robert Wertz (Alt.)
Toshiba America Electronic Components, Inc.	Mike Fitzpatrick Dan Colegrove (Alt.) Patrick Hery (Alt.) Don Jeanette (Alt.) Yuji Katori (Alt.) Tom McGoldrick (Alt.) Scott Wright (Alt.)
VMware, Inc.	Murali Rajagopal Tejasvi Aswathanarayana (Alt.) Nitish Kumar (Alt.) Lawrence Lamers (Alt.) Neil H. MacLean (Alt.) Ilia Sokolinski (Alt.)
Western Digital Corporation	Curtis Stevens Marvin DeForest (Alt.) Jason Gao (Alt.) Robert Griswold (Alt.) Farshad Khajavi (Alt.) Michael Koffman (Alt.) Christopher Reed (Alt.) Dan Reno (Alt.) Michael Rogers (Alt.) Ralph Weber (Alt.)
Xyratex	Alan Westbury Michael K. Connolly (Alt.) Neil Edmunds (Alt.)

**American National Standard
for Information Technology -**

SCSI over PCI Express® (SOP)

1 Scope

The SCSI family of standards provides for many different transport protocols that define the rules for exchanging information between different SCSI devices. This standard defines the rules for exchanging information between SCSI devices using a PCI Express queuing layer. Other SCSI transport protocol standards define the rules for exchanging information between SCSI devices using other interconnects.

This standard does not define the configuration of the PCI Express topology or the mechanisms for sending and receiving these messages across the PCI Express transport.

Figure 1 shows the relationship of this standard to the other standards and related projects in the SCSI family of standards as of the publication of this standard.

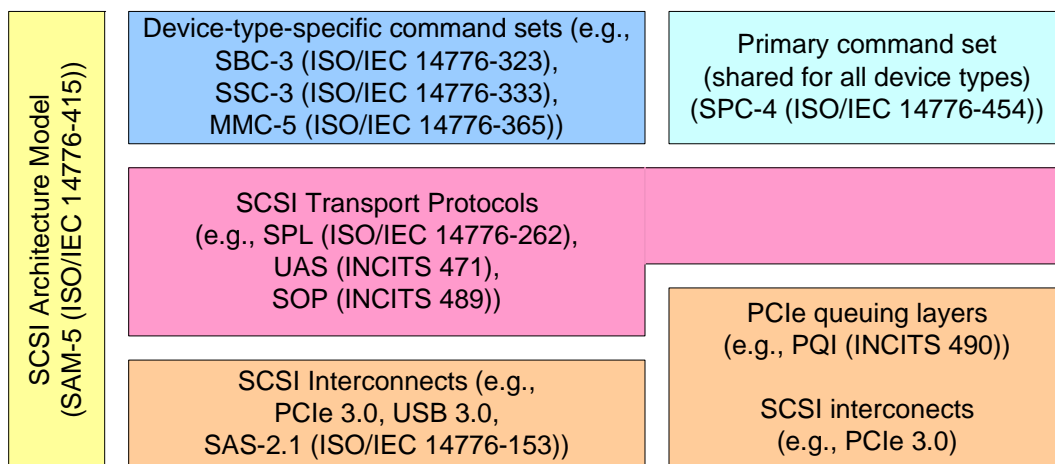

Figure 1 — SCSI document relationships