

This is a preview of "ISO 1050:1975". Click here to purchase the full version from the ANSI store.

# INTERNATIONAL STANDARD 1050

INTERNATIONAL ORGANIZATION FOR STANDARDIZATION • МЕЖДУНАРОДНАЯ ОРГАНИЗАЦИЯ ПО СТАНДАРТИЗАЦИИ • ORGANISATION INTERNATIONALE DE NORMALISATION

## Continuous mechanical handling equipment for loose bulk materials — Screw conveyors

*Engins de manutention continue pour produits en vrac — Transporteurs à vis*

First edition — 1975-10-15

OCT 2 - 1975

ANSI Internat Doc Sect

UDC 621.867.4

Ref. No. ISO 1050-1975 (E)

**Descriptors :** handling equipment, continuous handling, bulk products, conveyors, screw conveyors, dimensions.

Price based on 2 pages

## FOREWORD

ISO (the International Organization for Standardization) is a worldwide federation of national standards institutes (ISO Member Bodies). The work of developing International Standards is carried out through ISO Technical Committees. Every Member Body interested in a subject for which a Technical Committee has been set up has the right to be represented on that Committee. International organizations, governmental and non-governmental, in liaison with ISO, also take part in the work.

Draft International Standards adopted by the Technical Committees are circulated to the Member Bodies for approval before their acceptance as International Standards by the ISO Council.

Prior to 1972, the results of the work of the Technical Committees were published as ISO Recommendations; these documents are now in the process of being transformed into International Standards. As part of this process, Technical Committee ISO/TC 101 has reviewed ISO Recommendation R 1050 and found it technically suitable for transformation. International Standard ISO 1050 therefore replaces ISO Recommendation R 1050-1969 to which it is technically identical.

ISO Recommendation R 1050 was approved by the Member Bodies of the following countries :

Belgium	Germany	Poland
Brazil	Greece	South Africa, Rep. of
Canada	India	Sweden
Chile	Israel	Switzerland
Czechoslovakia	Italy	Turkey
Egypt, Arab Rep. of	Japan	United Kingdom
Finland	Korea, Rep. of	U.S.S.R.
France	Netherlands	Yugoslavia

The Member Body of the following country expressed disapproval of the Recommendation on technical grounds :

U.S.A.

No Member Body disapproved the transformation of ISO/R 1050 into an International Standard.

# Continuous mechanical handling equipment for loose bulk materials — Screw conveyors

## 1 SCOPE AND FIELD OF APPLICATION

This International Standard lays down the recommended values of the main dimensions of the screw conveyors' elements.

## 2 REFERENCES

ISO 496, *Driving and driven machines — Shaft heights.*

ISO/R 775, *Cylindrical and 1/10 conical shaft ends.*

## 3 DEFINITIONS

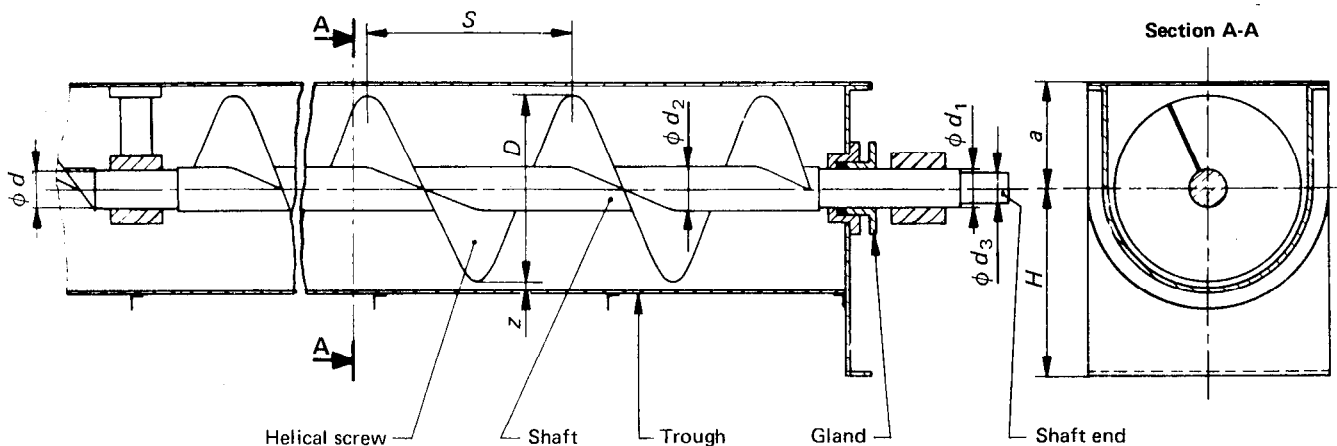

### 3.1 Helical screw

3.1.1 **nominal diameter** : The outside diameter,  $D$ , of the helical screw.

3.1.2 **pitch** : The pitch,  $S$ , of the helical screw.

### 3.2 Shaft

3.2.1 **constitution** : The shaft of the helical screw may be made either solid ( $\phi d_1$ ), or partly solid ( $\phi d_1$ ) and partly tubular ( $\phi d_2$ ).

3.2.2 **shaft end** : The driven end of the shaft ( $\phi d_3$ ).

### 3.3 Trough

3.3.1 **shaft height** : The height  $H$  of the shaft centre line above the foot of the trough support.

3.3.2 **height above shaft** : The distance  $a$  between the shaft centre line and the top of the trough.

3.3.3 **clearance** : The radial clearance  $z$  between the helical screw and the interior of the cylindrical part of the trough.