

This is a preview of "ISO 3539:1975". [Click here to purchase the full version from the ANSI store.](#)



INTERNATIONAL ORGANIZATION FOR STANDARDIZATION • МЕЖДУНАРОДНАЯ ОРГАНИЗАЦИЯ ПО СТАНДАРТИЗАЦИИ • ORGANISATION INTERNATIONALE DE NORMALISATION

Road vehicles – Injection nozzle holder with body, types 8 and 10, and injection nozzle holder with fixing flats, types 9 and 11

Véhicules routiers – Porte-injecteurs avec corps, types 8 et 10, et porte-injecteurs avec plats de fixation, types 9 et 11

First edition – 1975-09-15

UDC 621.43.03

Ref. No. ISO 3539-1975 (E)

Descriptors : road vehicles, injection nozzle holder, dimensions, dimensional tolerances.

This is a preview of "ISO 3539:1975". [Click here to purchase the full version from the ANSI store.](#)

FOREWORD

ISO (the International Organization for Standardization) is a worldwide federation of national standards institutes (ISO Member Bodies). The work of developing International Standards is carried out through ISO Technical Committees. Every Member Body interested in a subject for which a Technical Committee has been set up has the right to be represented on that Committee. International organizations, governmental and non-governmental, in liaison with ISO, also take part in the work.

Draft International Standards adopted by the Technical Committees are circulated to the Member Bodies for approval before their acceptance as International Standards by the ISO Council.

International Standard ISO 3539 was drawn up by Technical Committee ISO/TC 22, *Road vehicles*, and circulated to the Member Bodies in September 1974.

It has been approved by the Member Bodies of the following countries :

Belgium	Hungary	South Africa, Rep. of
Brazil	Iran	Sweden
Bulgaria	Italy	Switzerland
Canada	Netherlands	Turkey
Czechoslovakia	Poland	United Kingdom
France	Portugal	U.S.A.
Germany	Romania	Yugoslavia

No Member Body expressed disapproval of the document.

This is a preview of "ISO 3539:1975". Click here to purchase the full version from the ANSI store.

Road vehicles – Injection nozzle holder with body, types 8 and 10, and injection nozzle holder with fixing flats, types 9 and 11

1 SCOPE

This International Standard specifies the dimensional requirements necessary for mounting and interchangeability of injection nozzle holders in diesel engines.

The locations of the fuel inlet and leak-off connections are not defined, since they vary according to the particular application.

2 FIELD OF APPLICATION

This International Standard applies to the injection nozzle holder with body, types 8 and 10, and to the injection nozzle holder with fixing flats, types 9 and 11.

3 DIMENSIONS AND TOLERANCES (see figures 1 and 2)

(The preferred shank lengths are given in 3.2)

3.1 General dimensions

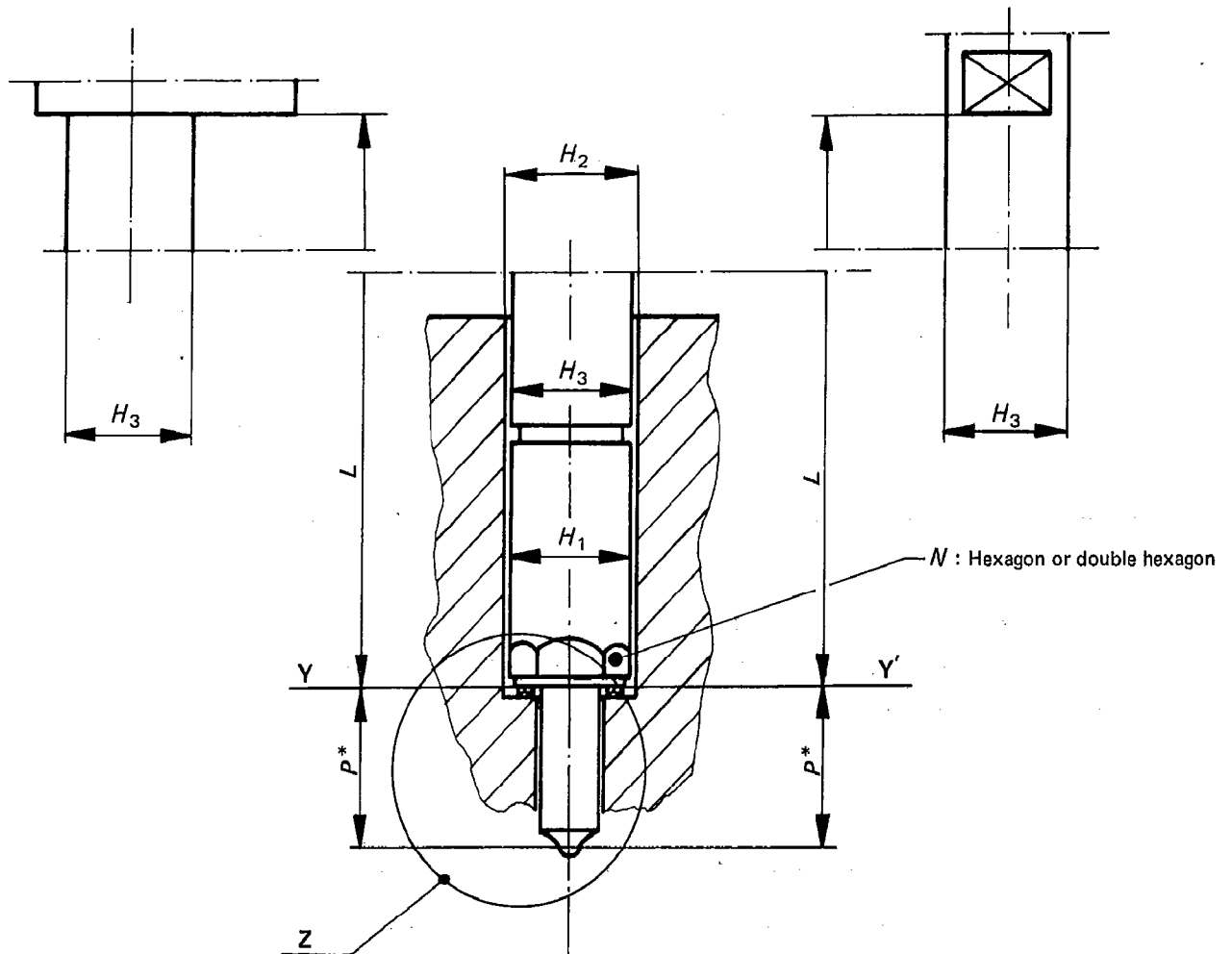

FIGURE 1 – Injection nozzle holder with body, types 8 and 10

FIGURE 2 – Injection nozzle holder with two fixing flats, types 9 and 11