



INTERNATIONAL STANDARD



Information technology – Small Computer System Interface (SCSI) – Part 263: SAS Protocol Layer – 3 (SPL-3)

INTERNATIONAL
ELECTROTECHNICAL
COMMISSION

ICS 35.200

ISBN 978-2-8322-6190-3

Warning! Make sure that you obtained this publication from an authorized distributor.

This is a preview of "ISO/IEC 14776-263:20...". Click here to purchase the full version from the ANSI store.

**Information technology -
Small Computer System Interface (SCSI) -
Part 263:SAS Protocol Layer - 3 (SPL-3)**

Reference
ISO/IEC 14775-263

This is a preview of "ISO/IEC 14776-263:20...". [Click here to purchase the full version from the ANSI store.](#)

1 Scope	44
2 Normative references	45
3 Terms, definitions, symbols, abbreviations, keywords, and conventions	46
3.1 Terms and definitions	46
3.2 Symbols and abbreviations	75
3.2.1 Abbreviations	75
3.2.2 Units	77
3.2.3 Symbols	77
3.2.4 Mathematical operators	78
3.3 Keywords	78
3.4 Editorial conventions	79
3.5 Numeric and character conventions	80
3.5.1 Numeric conventions	80
3.5.2 Units of measure	81
3.5.3 Byte encoded character strings conventions	82
3.6 UML notation conventions	82
3.6.1 Notation conventions overview	82
3.6.2 Constraint and note conventions	82
3.6.3 Class diagram conventions	83
3.6.4 Object diagram conventions	88
3.7 State machine conventions	90
3.7.1 State machine conventions overview	90
3.7.2 Transitions	91
3.7.3 Messages, requests, indications, confirmations, responses, and event notifications	91
3.7.4 State machine counters, timers, and variables	91
3.7.5 State machine arguments	92
3.8 Bit and byte ordering	92
3.9 Notation for procedures and functions	93
4 General	94
4.1 Architecture	94
4.1.1 Architecture overview	94
4.1.2 Physical links and phys	96
4.1.3 Logical links	100
4.1.4 Narrow ports and wide ports	100
4.1.5 Application clients and device servers	104
4.1.6 SAS devices	104
4.1.7 Expander devices	105
4.1.8 Service delivery subsystem	106
4.1.9 Domains	107
4.1.10 Expander device topologies	110
4.1.10.1 Expander device topology overview	110
4.1.10.2 Expander device topologies	111
4.1.11 Pathways	113
4.1.12 Connections	113
4.1.13 Persistent connections	115
4.1.13.1 Persistent connection operation	115
4.1.13.2 Persistent connection support	116
4.1.14 Advancing credit	116
4.1.15 Broadcasts	116
4.2 Names and identifiers	118

This is a preview of "ISO/IEC 14776-263:20...". [Click here to purchase the full version from the ANSI store.](#)

4.2.4 SAS address	121
4.2.5 Hashed SAS addresses	121
4.2.6 Device names and expander device SAS addresses	122
4.2.7 Device names for SATA devices with world wide names	123
4.2.8 Port names	123
4.2.9 Port identifiers and SAS port SAS addresses	123
4.2.10 Phy identifiers	124
4.3 State machines	125
4.3.1 State machine overview	125
4.3.2 Transmit data path	126
4.3.3 Receive data path	131
4.3.4 State machines and SAS Device, SAS Port, and SAS Phy classes	135
4.4 Events	137
4.4.1 Reset sequences	137
4.4.2 Hard reset	139
4.4.2.1 Hard reset overview	139
4.4.2.2 Additional hard reset processing by SAS ports	139
4.4.2.3 Additional hard reset processing by expander ports	139
4.4.3 I_T nexus loss	139
4.4.4 Power loss expected	140
4.5 Expander device model	141
4.5.1 Expander device model overview	141
4.5.2 Expander ports	142
4.5.3 Expander connection manager (ECM)	143
4.5.4 Expander connection router (ECR)	143
4.5.5 Broadcast propagation processor (BPP)	144
4.5.6 Expander device interfaces	144
4.5.6.1 Expander device interface overview	144
4.5.6.2 Expander device interfaces detail	146
4.5.6.3 ECM interface	147
4.5.6.4 ECR interface	149
4.5.6.5 BPP interface	151
4.5.7 Expander device routing	152
4.5.7.1 Routing attributes and routing methods	152
4.5.7.2 Expander device topology routing attribute restrictions	153
4.5.7.3 Connection request routing	153
4.5.7.4 Expander route table	153
4.5.7.4.1 Expander route table overview	153
4.5.7.4.2 Phy-based expander route table	154
4.5.7.4.3 Expander-based expander route table	155
4.5.8 Expander device reduced functionality	155
4.5.9 Broadcast (Expander) handling	156
4.6 Discover process	156
4.6.1 Discover process overview	156
4.6.2 Starting the discover process (Broadcast (Change) handling)	156
4.6.3 Discover process traversal	157
4.6.4 Discover process in a self-configuring expander device	159
4.6.5 Enabling multiplexing	160
4.7 Configuration subprocess	160
4.7.1 Configuration subprocess overview	160
4.7.2 Allowed expander device topologies	161
4.7.3 Externally configurable expander device route table optimization	162
4.7.4 Externally configurable expander device expander route index order	163
4.8 Zoning	170

This is a preview of "ISO/IEC 14776-263:20...". [Click here to purchase the full version from the ANSI store.](#)

4.8.3.1 Zone phy information.....	177
4.8.3.2 Zone groups	179
4.8.3.3 Zone permission table	180
4.8.3.4 Zoning expander route table	182
4.8.3.5 Source zone group and destination zone group determination.....	183
4.8.4 Zone phy information and link reset sequences	184
4.8.5 Broadcast processing in a zoning expander device with zoning enabled.....	187
4.8.6 Zone configuration	188
4.8.6.1 Zone configuration overview	188
4.8.6.2 Lock step.....	188
4.8.6.3 Load step.....	189
4.8.6.4 Activate step.....	190
4.8.6.5 Unlock step.....	190
4.8.6.6 Zone lock inactivity timer	191
4.8.6.7 Enable a zoning expander device	191
4.9 SAS device and expander device power conditions.....	191
4.10 Phy power conditions	192
4.10.1 Low phy power conditions.....	192
4.10.1.1 Low phy power conditions overview.....	192
4.10.1.2 Active phy power condition.....	192
4.10.1.3 Partial phy power condition	192
4.10.1.4 Slumber phy power condition	192
4.10.1.5 End device low phy power conditions	193
4.10.1.6 Expander device low phy power conditions	193
4.10.2 SATA phy power conditions.....	194
4.11 Phy test functions	194
4.11.1 Phy test functions overview	194
4.11.2 Transmit pattern phy test function.....	195
4.12 Phy events.....	195
4.13 Using POWER DISABLE signal to create a power on event.....	200
4.13.1 Using POWER DISABLE signal to create a power on event overview.....	200
4.13.2 Discovering POWER DISABLE signal support.....	200
4.13.3 Using a management device server to control the POWER DISABLE signal	201
5 Phy layer	202
5.1 Phy layer overview	202
5.2 8b10b coding	202
5.2.1 8b10b coding overview	202
5.2.2 8b10b coding notation conventions	202
5.3 Character encoding and decoding.....	203
5.3.1 Character encoding and decoding overview.....	203
5.3.2 Bit transmission order	203
5.3.3 Character transmission order.....	203
5.3.4 Frame transmission order	204
5.3.5 Running disparity (RD).....	204
5.3.6 Data characters.....	204
5.3.7 Control characters.....	210
5.3.8 Encoding characters in the transmitter	211
5.3.9 Decoding characters in the receiver	211
5.4 Dwords, primitives, data dwords, and invalid dwords.....	212
5.5 Bit order	212
5.6 Out of band (OOB) signals	214
5.6.1 OOB signals overview.....	214
5.6.2 Transmission of OOB signals	215

This is a preview of "ISO/IEC 14776-263:20...". [Click here to purchase the full version from the ANSI store.](#)

5.7	Phy capabilities bits	218
5.8	BMC coding	222
5.8.1	BMC coding overview	222
5.8.2	TTIU bit cell encoding in the transmitter	223
5.8.3	TTIU bit transmission order.....	224
5.8.4	TTIU bit cell decoding in the receiver.....	224
5.9	Train_Tx-SNW TTIUs	225
5.9.1	Train_Tx-SNW TTIU format	225
5.9.2	Control/Status TTIU	226
5.9.3	Error Response TTIU.....	230
5.10	Phy reset sequences	233
5.10.1	Phy reset sequences overview	233
5.10.2	SATA phy reset sequence	234
5.10.2.1	SATA OOB sequence	234
5.10.2.2	SATA speed negotiation sequence	234
5.10.3	SAS to SATA phy reset sequence	235
5.10.4	SAS to SAS phy reset sequence	236
5.10.4.1	SAS OOB sequence.....	236
5.10.4.2	SAS speed negotiation sequence	239
5.10.4.2.1	SAS speed negotiation sequence overview	239
5.10.4.2.2	SAS speed negotiation sequence timing specifications	240
5.10.4.2.3	Speed negotiation window (SNW) definitions	241
5.10.4.2.3.1	SNW definitions overview	241
5.10.4.2.3.2	SNW-1, SNW-2, and Final-SNW.....	242
5.10.4.2.3.3	SNW-3.....	243
5.10.4.2.3.4	Train_Tx-SNW	245
5.10.4.2.3.4.1	Phy's transmitter initial condition	245
5.10.4.2.3.4.2	Transmitter training.....	245
5.10.4.2.3.4.3	Pattern marker.....	246
5.10.4.2.3.5	Train_Rx-SNW	248
5.10.4.2.4	SAS speed negotiation sequence.....	251
5.10.4.2.5	SAS speed negotiation sequence examples	252
5.10.4.2.6	Train_Tx pattern sequence.....	260
5.10.4.2.6.1	Train_Tx pattern sequence overview	260
5.10.4.2.6.2	Train_Tx pattern initial sequence	261
5.10.4.2.6.3	Train_Tx pattern handshake sequence.....	264
5.10.4.2.6.3.1	Train_Tx pattern handshake sequence overview.....	264
5.10.4.2.6.3.2	Attached phy's receiver increment or decrement request	264
5.10.4.2.6.3.3	Attached phy's receiver reference_1, reference_2, or no_equalization request	267
5.10.4.2.6.4	Train_Tx pattern completion sequence.....	269
5.10.4.2.6.5	Invalid TTIU sequence	272
5.10.4.3	Multiplexing sequence.....	273
5.10.5	Phy reset sequence after devices are attached.....	274
5.11	Phy power condition sequences.....	275
5.11.1	Transitioning from the active phy power condition to a low phy power condition	275
5.11.2	Transitioning from a low phy power condition to the active phy power condition	276
5.11.3	Events during low phy power condition.....	276
5.12	SP (phy layer) state machine	278
5.12.1	SP state machine overview.....	278
5.12.2	SP transmitter and SP receiver.....	280
5.12.3	OOB sequence states.....	283
5.12.3.1	OOB sequence states overview	283
5.12.3.2	SP0:OOB_COMINIT state.....	284
5.12.3.2.1	State description	284

This is a preview of "ISO/IEC 14776-263:20...". [Click here to purchase the full version from the ANSI store.](#)

5.12.3.3 SP1:OOB_AwaitCOMX state	285
5.12.3.3.1 State description	285
5.12.3.3.2 Transition SP1:OOB_AwaitCOMX to SP0:OOB_COMINIT	285
5.12.3.3.3 Transition SP1:OOB_AwaitCOMX to SP4:OOB_COMSAS	285
5.12.3.4 SP2:OOB_NoCOMSASTimeout state	286
5.12.3.4.1 State description	286
5.12.3.4.2 Transition SP2:OOB_NoCOMSASTimeout to SP0:OOB_COMINIT	286
5.12.3.4.3 Transition SP2:OOB_NoCOMSASTimeout to SP4:OOB_COMSAS	286
5.12.3.5 SP3:OOB_AwaitCOMINIT_Sent state	286
5.12.3.5.1 State description	286
5.12.3.5.2 Transition SP3:OOB_AwaitCOMINIT_Sent to SP4:OOB_COMSAS	286
5.12.3.6 SP4:OOB_COMSAS state	286
5.12.3.6.1 State description	286
5.12.3.6.2 Transition SP4:OOB_COMSAS to SP5:OOB_AwaitCOMSAS_Sent	287
5.12.3.6.3 Transition SP4:OOB_COMSAS to SP6:OOB_AwaitNoCOMSAS	287
5.12.3.6.4 Transition SP4:OOB_COMSAS to SP7:OOB_AwaitCOMSAS	287
5.12.3.7 SP5:OOB_AwaitCOMSAS_Sent state	287
5.12.3.7.1 State description	287
5.12.3.7.2 Transition SP5:OOB_AwaitCOMSAS_Sent to SP6:OOB_AwaitNoCOMSAS	287
5.12.3.8 SP6:OOB_AwaitNoCOMSAS state	287
5.12.3.8.1 State description	287
5.12.3.8.2 Transition SP6:OOB_AwaitNoCOMSAS to SP0:OOB_COMINIT	287
5.12.3.8.3 Transition SP6:OOB_AwaitNoCOMSAS to SP8:SAS_Start	288
5.12.3.9 SP7:OOB_AwaitCOMSAS state	288
5.12.3.9.1 State description	288
5.12.3.9.2 Transition SP7:OOB_AwaitCOMSAS to SP2:OOB_NoCOMSASTimeout	288
5.12.3.9.3 Transition SP7:OOB_AwaitCOMSAS to SP6:OOB_AwaitNoCOMSAS	288
5.12.3.9.4 Transition SP7:OOB_AwaitCOMSAS to SP16:SATA_COMWAKE	288
5.12.3.9.5 Transition SP7:OOB_AwaitCOMSAS to SP26:SATA_SpinupHold	288
5.12.4 SAS speed negotiation states	289
5.12.4.1 SAS speed negotiation states overview	289
5.12.4.2 Negotiation idle	289
5.12.4.3 SP8:SAS_Start state	292
5.12.4.3.1 State description	292
5.12.4.3.2 Transition SP8:SAS_Start to SP0:OOB_COMINIT	292
5.12.4.3.3 Transition SP8:SAS_Start to SP1:OOB_AwaitCOMX	293
5.12.4.3.4 Transition SP8:SAS_Start to SP9:SAS_WindowNotSupported	293
5.12.4.3.5 Transition SP8:SAS_Start to SP10:SAS_AwaitALIGN	293
5.12.4.3.6 Transition SP8:SAS_Start to SP27:SAS_Settings	293
5.12.4.4 SP9:SAS_WindowNotSupported state	293
5.12.4.4.1 State description	293
5.12.4.4.2 Transition SP9:SAS_WindowNotSupported to SP0:OOB_COMINIT	293
5.12.4.4.3 Transition SP9:SAS_WindowNotSupported to SP14:SAS_Fail	293
5.12.4.5 SP10:SAS_AwaitALIGN state	293
5.12.4.5.1 State description	293
5.12.4.5.2 Transition SP10:SAS_AwaitALIGN to SP0:OOB_COMINIT	294
5.12.4.5.3 Transition SP10:SAS_AwaitALIGN to SP11:SAS_AwaitALIGN1	294
5.12.4.5.4 Transition SP10:SAS_AwaitALIGN to SP12:SAS_AwaitSNW	294
5.12.4.5.5 Transition SP10:SAS_AwaitALIGN to SP14:SAS_Fail	294
5.12.4.6 SP11:SAS_AwaitALIGN1 state	294
5.12.4.6.1 State description	294
5.12.4.6.2 Transition SP11:SAS_AwaitALIGN1 to SP0:OOB_COMINIT	294
5.12.4.6.3 Transition SP11:SAS_AwaitALIGN1 to SP12:SAS_AwaitSNW	294
5.12.4.6.4 Transition SP11:SAS_AwaitALIGN1 to SP14:SAS_Fail	294

This is a preview of "ISO/IEC 14776-263:20...". [Click here to purchase the full version from the ANSI store.](#)

5.12.4.7.3 Transition SP12:SAS_AwaitSNW to SP13:SAS_Pass	295
5.12.4.8 SP13:SAS_Pass state	295
5.12.4.8.1 State description	295
5.12.4.8.2 Transition SP13:SAS_Pass to SP0:OOB_COMINIT	295
5.12.4.8.3 Transition SP13:SAS_Pass to SP8:SAS_Start	295
5.12.4.8.4 Transition SP13:SAS_Pass to SP15:SAS_PHY_Ready	296
5.12.4.9 SP14:SAS_Fail state	296
5.12.4.9.1 State description	296
5.12.4.9.2 Transition SP14:SAS_Fail to SP1:OOB_AwaitCOMX	296
5.12.4.9.3 Transition SP14:SAS_Fail to SP8:SAS_Start	296
5.12.4.10 SP15:SAS_PHY_Ready state	296
5.12.4.10.1 State description	296
5.12.4.10.2 Transition SP15:SAS_PHY_Ready to SP0:OOB_COMINIT	297
5.12.4.10.3 Transition SP15:SAS_PHY_Ready to SP31:SAS_PS_Low_Phy_Power	297
5.12.4.11 SP27:SAS_Settings state	297
5.12.4.11.1 State description	297
5.12.4.11.2 Transition SP27:SAS_Settings to SP0:OOB_COMINIT	297
5.12.4.11.3 Transition SP27:SAS_Settings to SP1:OOB_AwaitCOMX	298
5.12.4.11.4 Transition SP27:SAS_Settings to SP8:SAS_Start	298
5.12.4.11.5 Transition SP27:SAS_Settings to SP28:SAS_TrainSetup	298
5.12.4.12 SP28:SAS_TrainSetup	298
5.12.4.12.1 State description	298
5.12.4.12.2 Transition SP28:SAS_TrainSetup to SP0:OOB_COMINIT	299
5.12.4.12.3 Transition SP28:SAS_TrainSetup to SP29:SAS_Train_Rx	299
5.12.4.12.4 Transition SP28:SAS_TrainSetup to SP34:SAS_Train_Tx	299
5.12.4.13 SP34:SAS_Train_Tx state	299
5.12.4.13.1 State description	299
5.12.4.13.2 Transition SP34:SAS_Train_Tx to SP1:OOB_AwaitCOMX	299
5.12.4.13.3 Transition SP34:SAS_Train_Tx to SP28:SAS_TrainSetup	299
5.12.4.13.4 Transition SP34:SAS_Train_Tx to SP29:SAS_Train_Rx	300
5.12.4.14 SP29:SAS_Train_Rx state	300
5.12.4.14.1 State description	300
5.12.4.14.2 Transition SP29:SAS_Train_Rx to SP0:OOB_COMINIT	300
5.12.4.14.3 Transition SP29:SAS_Train_Rx to SP1:OOB_AwaitCOMX	300
5.12.4.14.4 Transition SP29:SAS_Train_Rx to SP28:SAS_TrainSetup	301
5.12.4.14.5 Transition SP29:SAS_Train_Rx to SP30:SAS_TrainingDone	301
5.12.4.15 SP30:SAS_TrainingDone state	301
5.12.4.15.1 State description	301
5.12.4.15.2 Transition SP30:SAS_TrainingDone to SP0:OOB_COMINIT	301
5.12.4.15.3 Transition SP30:SAS_TrainingDone to SP1:OOB_AwaitCOMX	302
5.12.4.15.4 Transition SP30:SAS_TrainingDone to SP28:SAS_TrainSetup	302
5.12.4.15.5 Transition SP30:SAS_TrainingDone to SP15:SAS_PHY_Ready	302
5.12.5 SAS phy power conditions states	302
5.12.5.1 SAS phy power conditions states overview	302
5.12.5.2 SP31:SAS_PS_Low_Phy_Power state	303
5.12.5.2.1 State description	303
5.12.5.2.2 Transition SP31:SAS_PS_Low_Phy_Power to SP0:OOB_COMINIT	304
5.12.5.2.3 Transition SP31:SAS_PS_Low_Phy_Power to SP32:SAS_PS_ALIGN0	304
5.12.5.3 SP32:SAS_PS_ALIGN0 state	304
5.12.5.3.1 State description	304
5.12.5.3.2 Transition SP32:SAS_PS_ALIGN0 state to SP0:OOB_COMINIT	304
5.12.5.3.3 Transition SP32:SAS_PS_ALIGN0 to SP33:SAS_PS_ALIGN1	305
5.12.5.4 SP33:SAS_PS_ALIGN1 state	305
5.12.5.4.1 State description	305

This is a preview of "ISO/IEC 14776-263:20...". [Click here to purchase the full version from the ANSI store.](#)

5.12.6.1	SATA host emulation states overview	305
5.12.6.2	SP16:SATA_COMWAKE state	307
5.12.6.2.1	State description	307
5.12.6.2.2	Transition SP16:SATA_COMWAKE to SP0:OOB_COMINIT	307
5.12.6.2.3	Transition SP16:SATA_COMWAKE to SP17:SATA_AwaitCOMWAKE	307
5.12.6.3	SP17:SATA_AwaitCOMWAKE state	307
5.12.6.3.1	State description	307
5.12.6.3.2	Transition SP17:SATA_AwaitCOMWAKE to SP0:OOB_COMINIT	307
5.12.6.3.3	Transition SP17:SATA_AwaitCOMWAKE to SP18:SATA_AwaitNoCOMWAKE	307
5.12.6.4	SP18:SATA_AwaitNoCOMWAKE state	307
5.12.6.4.1	State description	307
5.12.6.4.2	Transition SP18:SATA_AwaitNoCOMWAKE to SP0:OOB_COMINIT	307
5.12.6.4.3	Transition SP18:SATA_AwaitNoCOMWAKE to SP19:SATA_AwaitALIGN	307
5.12.6.5	SP19:SATA_AwaitALIGN state	308
5.12.6.5.1	State description	308
5.12.6.5.2	Transition SP19:SATA_AwaitALIGN to SP0:OOB_COMINIT	308
5.12.6.5.3	Transition SP19:SATA_AwaitALIGN to SP20:SATA_AdjustSpeed	308
5.12.6.6	SP20:SATA_AdjustSpeed state	308
5.12.6.6.1	State description	308
5.12.6.6.2	Transition SP20:SATA_AdjustSpeed to SP0:OOB_COMINIT	308
5.12.6.6.3	Transition SP20:SATA_AdjustSpeed to SP21:SATA_TransmitALIGN	309
5.12.6.7	SP21:SATA_TransmitALIGN state	309
5.12.6.7.1	State description	309
5.12.6.7.2	Transition SP21:SATA_TransmitALIGN to SP0:OOB_COMINIT	309
5.12.6.7.3	Transition SP21:SATA_TransmitALIGN to SP22:SATA_PHY_Ready	309
5.12.6.8	SP22:SATA_PHY_Ready state	309
5.12.6.8.1	State description	309
5.12.6.8.2	Transition SP22:SATA_PHY_Ready to SP0:OOB_COMINIT	309
5.12.6.8.3	Transition SP22:SATA_PHY_Ready to SP23:SATA_PM_Partial	310
5.12.6.8.4	Transition SP22:SATA_PHY_Ready to SP24:SATA_PM_Slumber	310
5.12.6.9	SP23:SATA_PM_Partial state	310
5.12.6.9.1	State description	310
5.12.6.9.2	Transition SP23:SATA_PM_Partial to SP0:OOB_COMINIT	310
5.12.6.9.3	Transition SP23:SATA_PM_Partial to SP16:SATA_COMWAKE	310
5.12.6.9.4	Transition SP23:SATA_PM_Partial to SP19:SATA_AwaitALIGN	310
5.12.6.10	SP24:SATA_PM_Slumber state	310
5.12.6.10.1	State description	310
5.12.6.10.2	Transition SP24:SATA_PM_Slumber to SP0:OOB_COMINIT	310
5.12.6.10.3	Transition SP24:SATA_PM_Slumber to SP16:SATA_COMWAKE	311
5.12.6.10.4	Transition SP24:SATA_PM_Slumber to SP19:SATA_AwaitALIGN	311
5.12.7	SATA port selector state SP25:SATA_PortSel	311
5.12.7.1	State description	311
5.12.7.2	Transition SP25:SATA_PortSel to SP1:OOB_AwaitCOMX	311
5.12.8	SATA spinup hold state SP26:SATA_SpinupHold	312
5.12.8.1	State description	312
5.12.8.2	Transition SP26:SATA_SpinupHold to SP0:OOB_COMINIT	312
5.13	SP_DWS (phy layer dword synchronization) state machine	312
5.13.1	SP_DWS state machine overview	312
5.13.2	SP_DWS receiver	314
5.13.3	SP_DWS0:AcquireSync state	315
5.13.3.1	State description	315
5.13.3.2	Transition SP_DWS0:AcquireSync to SP_DWS1:Valid1	315
5.13.4	SP_DWS1:Valid1 state	316
5.13.4.1	State description	316

This is a preview of "ISO/IEC 14776-263:20...". [Click here to purchase the full version from the ANSI store.](#)

5.13.5.1 State description.....	316
5.13.5.2 Transition SP_DWS2:Valid2 to SP_DWS0:AcquireSync.....	316
5.13.5.3 Transition SP_DWS2:Valid2 to SP_DWS3:SyncAcquired.....	316
5.13.6 SP_DWS3:SyncAcquired state.....	316
5.13.6.1 State description.....	316
5.13.6.2 Transition SP_DWS3:SyncAcquired to SP_DWS0:AcquireSync.....	317
5.13.6.3 Transition SP_DWS3:SyncAcquired to SP_DWS4:Lost1.....	317
5.13.7 SP_DWS4:Lost1 state.....	317
5.13.7.1 State description.....	317
5.13.7.2 Transition SP_DWS4:Lost1 to SP_DWS0:AcquireSync.....	317
5.13.7.3 Transition SP_DWS4:Lost1 to SP_DWS5:Lost1Recovered.....	317
5.13.7.4 Transition SP_DWS4:Lost1 to SP_DWS6:Lost2.....	317
5.13.8 SP_DWS5:Lost1Recovered state.....	317
5.13.8.1 State description.....	317
5.13.8.2 Transition SP_DWS5:Lost1Recovered to SP_DWS0:AcquireSync.....	317
5.13.8.3 Transition SP_DWS5:Lost1Recovered to SP_DWS3:SyncAcquired.....	318
5.13.8.4 Transition SP_DWS5:Lost1Recovered to SP_DWS6:Lost2.....	318
5.13.9 SP_DWS6:Lost2 state.....	318
5.13.9.1 State description.....	318
5.13.9.2 Transition SP_DWS6:Lost2 to SP_DWS0:AcquireSync.....	318
5.13.9.3 Transition SP_DWS6:Lost2 to SP_DWS7:Lost2Recovered.....	318
5.13.9.4 Transition SP_DWS6:Lost2 to SP_DWS8:Lost3.....	318
5.13.10 SP_DWS7:Lost2Recovered state.....	318
5.13.10.1 State description.....	318
5.13.10.2 Transition SP_DWS7:Lost2Recovered to SP_DWS0:AcquireSync.....	318
5.13.10.3 Transition SP_DWS7:Lost2Recovered to SP_DWS4:Lost1.....	319
5.13.10.4 Transition SP_DWS7:Lost2Recovered to SP_DWS8:Lost3.....	319
5.13.11 SP_DWS8:Lost3 state.....	319
5.13.11.1 State description.....	319
5.13.11.2 Transition SP_DWS8:Lost3 to SP_DWS0:AcquireSync.....	319
5.13.11.3 Transition SP_DWS8:Lost3 to SP_DWS9:Lost3Recovered.....	319
5.13.12 SP_DWS9:Lost3Recovered state.....	319
5.13.12.1 State description.....	319
5.13.12.2 Transition SP_DWS9:Lost3Recovered to SP_DWS0:AcquireSync.....	319
5.13.12.3 Transition SP_DWS9:Lost3Recovered to SP_DWS6:Lost2.....	320
5.14 PTT (phy layer transmitter training) state machines.....	320
5.14.1 PTT state machines overview.....	320
5.14.2 SP transmitter additions for transmitter training.....	320
5.14.2.1 SP transmitter additions for transmitter training overview.....	320
5.14.2.2 TTIU transmit setup.....	321
5.14.2.3 No_equalization, reference_1, and reference_2 coefficient settings request.....	321
5.14.2.4 Coefficient limits.....	321
5.14.2.5 Coefficient request result of update complete.....	321
5.14.2.5.1 Coefficient request processing.....	321
5.14.2.5.2 Coefficient adjustment completes.....	322
5.14.2.5.3 No coefficient adjustment.....	322
5.14.2.6 Coefficient request result of maximum.....	322
5.14.2.6.1 Coefficient request processing.....	322
5.14.2.6.2 Coefficient adjustment completes.....	323
5.14.2.6.3 No coefficient adjustment.....	323
5.14.2.7 Coefficient request result of minimum.....	323
5.14.2.7.1 Coefficient request processing.....	323
5.14.2.7.2 Coefficient adjustment completes.....	323
5.14.2.7.3 No coefficient adjustment.....	323

This is a preview of "ISO/IEC 14776-263:20...". [Click here to purchase the full version from the ANSI store.](#)

5.14.4.2 PTT_T0:Idle state	327
5.14.4.2.1 State description	327
5.14.4.2.2 Transition PTT_T0:Idle to PTT_T1:Initialize	327
5.14.4.3 PTT_T1:Initialize state	327
5.14.4.3.1 State description	327
5.14.4.3.2 Transition PTT_T1:Initialize to PTT_T0:Idle	327
5.14.4.3.3 Transition PTT_T1:Initialize to PTT_T2:Tx_Training	328
5.14.4.4 PTT_T2:Tx_Training state	328
5.14.4.4.1 State description	328
5.14.4.4.2 Entry conditions	328
5.14.4.4.3 Control word and status word mappings	329
5.14.4.4.4 Error message handling	330
5.14.4.4.5 Resetting attached phy's transmitter	330
5.14.4.4.6 Local phy's transmitter and attached phy's transmitter training completed	331
5.14.4.4.7 Transition PTT_T2:Tx_Training to PTT_T0:Idle	331
5.14.4.4.8 Transition PTT_T2:Tx_Training to PTT_T3:Local_Tx_Training	332
5.14.4.5 PTT_T3:Local_Tx_Training state	332
5.14.4.5.1 State description	332
5.14.4.5.2 Entry conditions	332
5.14.4.5.3 Status word mappings	332
5.14.4.5.4 Local phy's transmitter and attached phy's transmitter training completed	332
5.14.4.5.5 Error message handling	333
5.14.4.5.6 Transition PTT_T3:Local_Tx_Training to PTT_T0:Idle	333
5.14.5 PTT_R (phy layer transmitter training receive pattern) state machine	333
5.14.5.1 PTT_R state machine overview	333
5.14.5.2 PTT_R0:Idle state	335
5.14.5.2.1 State description	335
5.14.5.2.2 Transition PTT_R0:Idle to PTT_R1:Initialize	335
5.14.5.3 PTT_R1:Initialize state	335
5.14.5.3.1 State description	335
5.14.5.3.2 Transition PTT_R1:Initialize to PTT_R0:Idle	335
5.14.5.3.3 Transition PTT_R1:Initialize to PTT_R2:Receive_Train_Tx_Pattern	335
5.14.5.4 PTT_R2:Receive_Train_Tx_Pattern state	335
5.14.5.4.1 State description	335
5.14.5.4.2 Transition PTT_R2:Receive_Train_Tx_Pattern to PTT_R0:Idle	341
5.14.5.4.3 Transition PTT_R2:Receive_Train_Tx_Pattern to PTT_R1:Initialize	341
5.14.6 PTT_SC (phy layer transmitter training set transmitter coefficient) state machines	341
5.14.6.1 PTT_SC (phy layer transmitter training set transmitter coefficient) state machines overview	341
5.14.6.2 PTT_SC1 state machine overview	343
5.14.6.3 PTT_SC1_0:Idle state	343
5.14.6.3.1 State description	343
5.14.6.3.2 Transition PTT_SC1_0:Idle to PTT_SC1_1:Wait_Inc_Dec	343
5.14.6.4 PTT_SC1_1:Wait_Inc_Dec state	343
5.14.6.4.1 State description	343
5.14.6.4.2 Transition PTT_SC1_1:Wait_Inc_Dec to PTT_SC1_0:Idle	343
5.14.6.4.3 Transition PTT_SC1_1:Wait_Inc_Dec to PTT_SC1_2:Set_Coefficient	343
5.14.6.5 PTT_SC1_2:Set_Coefficient state	344
5.14.6.5.1 State description	344
5.14.6.5.2 Transition PTT_SC1_2:Set_Coefficient to PTT_SC1_0:Idle	345
5.14.6.5.3 Transition PTT_SC1_2:Set_Coefficient to PTT_SC1_3:Wait_Hold	345
5.14.6.6 PTT_SC1_3:Wait_Hold state	345
5.14.6.6.1 State description	345
5.14.6.6.2 Transition PTT_SC1_3:Wait_Hold to PTT_SC1_0:Idle	345
5.14.6.6.3 Transition PTT_SC1_3:Wait_Hold to PTT_SC1_1:Wait_Inc_Dec	345

This is a preview of "ISO/IEC 14776-263:20...". [Click here to purchase the full version from the ANSI store.](#)

5.14.9.1 PTT_GC (phy layer transmitter training get transmitter coefficient) state machines overview	346
5.14.9.2 PTT_GC1 state machine	347
5.14.9.3 PTT_GC1_0:Idle state	348
5.14.9.3.1 State description	348
5.14.9.3.2 Transition PTT_GC1_0:Idle to PTT_GC1_1:Get_Coefficient	348
5.14.9.4 PTT_GC1_1:Get_Coefficient state	348
5.14.9.4.1 State description	348
5.14.9.4.2 Transition PTT_GC1_1:Get_Coefficient to PTT_GC1_0:Idle	348
5.14.9.4.3 Transition PTT_GC1_1:Get_Coefficient to PTT_GC1_2:Wait_Restart	348
5.14.9.5 PTT_GC1_2:Wait_Restart state	349
5.14.9.5.1 State description	349
5.14.9.5.2 Transition PTT_GC1_2:Wait_Restart to PTT_GC1_0:Idle	349
5.14.10 PTT_GC2 (phy layer transmitter training get transmitter coefficient 2) state machine	349
5.14.11 PTT_GC3 (phy layer transmitter training get transmitter coefficient 3) state machine	349
5.14.12 PTT_PL (phy layer transmitter training pattern lock) state machine	350
5.14.12.1 PTT_PL state machine overview	350
5.14.12.2 PTT_PL0:Idle state	351
5.14.12.2.1 State description	351
5.14.12.2.2 Transition PTT_PL0:Idle to PTT_PL1:Acquire_Lock	352
5.14.12.3 PTT_PL1:Acquire_Lock state	352
5.14.12.3.1 State description	352
5.14.12.3.2 Transition PTT_PL1:Acquire_Lock to PTT_PL2:Valid	352
5.14.12.4 PTT_PL2:Valid state	352
5.14.12.4.1 State description	352
5.14.12.4.2 Transition PTT_PL2:Valid to PTT_PL1:Acquire_Lock	352
5.14.12.4.3 Transition PTT_PL2:Valid to PTT_PL3:Lock_Acquired	352
5.14.12.5 PTT_PL3:Lock_Acquired state	352
5.14.12.5.1 State description	352
5.14.12.5.2 Transition PTT_PL3:Lock_Acquired to PTT_PL4:Lost1	352
5.14.12.6 PTT_PL4:Lost1 state	353
5.14.12.6.1 State description	353
5.14.12.6.2 Transition PTT_PL4:Lost1 to PTT_PL3:Lock_Acquired	353
5.14.12.6.3 Transition PTT_PL4:Lost1 to PTT_PL5:Lost2	353
5.14.12.7 PTT_PL5:Lost2 state	353
5.14.12.7.1 State description	353
5.14.12.7.2 Transition PTT_PL5:Lost2 to PTT_PL3:Lock_Acquired	353
5.14.12.7.3 Transition PTT_PL5:Lost2 to PTT_PL6:Lost3	353
5.14.12.8 PTT_PL6:Lost3 state	353
5.14.12.8.1 State description	353
5.14.12.8.2 Transition PTT_PL6:Lost3 to PTT_PL3:Lock_Acquired	353
5.14.12.8.3 Transition PTT_PL6:Lost3 to PTT_PL7:Lost4	353
5.14.12.9 PTT_PL7:Lost4 state	353
5.14.12.9.1 State description	353
5.14.12.9.2 Transition PTT_PL7:Lost4 to PTT_PL3:Lock_Acquired	354
5.14.12.9.3 Transition PTT_PL7:Lost4 to PTT_PL1:Acquire_Lock	354
5.15 Multiplexing	354
5.16 Spinup	355
6 Link layer	356
6.1 Link layer overview	356
6.2 Primitives	356
6.2.1 Primitives overview	356
6.2.2 Primitive summary	357
6.2.3 Primitive encodings	366

This is a preview of "ISO/IEC 14776-263:20...". [Click here to purchase the full version from the ANSI store.](#)

6.2.4.3 Repeated primitive sequence	371
6.2.4.4 Continued primitive sequence	372
6.2.4.5 Extended primitive sequence	372
6.2.4.6 Triple primitive sequence	373
6.2.4.7 Redundant primitive sequence	374
6.2.5 Deletable primitives	375
6.2.5.1 ALIGN	375
6.2.5.2 MUX (Multiplex)	376
6.2.5.3 NOTIFY	377
6.2.5.3.1 NOTIFY overview	377
6.2.5.3.2 NOTIFY (ENABLE SPINUP)	377
6.2.5.3.3 NOTIFY (POWER LOSS EXPECTED)	378
6.2.5.4 OOB_IDLE	379
6.2.6 Primitives not specific to type of connections	379
6.2.6.1 AIP (Arbitration in progress)	379
6.2.6.2 BREAK	379
6.2.6.3 BREAK_REPLY	380
6.2.6.4 BROADCAST	380
6.2.6.5 CLOSE	380
6.2.6.6 EOAF (End of address frame)	381
6.2.6.7 ERROR	381
6.2.6.8 HARD_RESET	381
6.2.6.9 OPEN_ACCEPT	381
6.2.6.10 OPEN_REJECT	381
6.2.6.11 PS_ACK	384
6.2.6.12 PS_NAK	384
6.2.6.13 PS_REQ	384
6.2.6.14 PWR_ACK	384
6.2.6.15 PWR_DONE	384
6.2.6.16 PWR_GRANT	384
6.2.6.17 PWR_REQ	384
6.2.6.18 SOAF (Start of address frame)	385
6.2.6.19 TRAIN	385
6.2.6.20 TRAIN_DONE	385
6.2.7 Primitives used only inside SSP and SMP connections	385
6.2.7.1 ACK (Acknowledge)	385
6.2.7.2 CREDIT_BLOCKED	385
6.2.7.3 DONE	385
6.2.7.4 EOF (End of frame)	386
6.2.7.5 EXTEND_CONNECTION	386
6.2.7.6 NAK (Negative acknowledgement)	386
6.2.7.7 RRDY (Receiver ready)	387
6.2.7.8 SOF (Start of frame)	387
6.2.8 Primitives used only inside STP connections and on SATA physical links	387
6.2.8.1 SATA_ERROR	387
6.2.8.2 SATA_PMACK, SATA_PMNAK, SATA_PMREQ_P, and SATA_PMREQ_S (Power management acknowledgements and requests)	388
6.2.8.3 SATA_HOLD and SATA_HOLDA (Hold and hold acknowledge)	388
6.2.8.4 SATA_R_RDY and SATA_X_RDY (Receiver ready and transmitter ready)	388
6.2.8.5 Other primitives used inside STP connections and on SATA physical links	388
6.3 Physical link rate tolerance management	388
6.3.1 Physical link rate tolerance management overview	388
6.3.2 Phys originating dwords	389
6.3.3 Expander phys forwarding dwords	390

This is a preview of "ISO/IEC 14776-263:20...". [Click here to purchase the full version from the ANSI store.](#)

6.5.2 CRC generation	393
6.5.3 CRC checking	395
6.6 Scrambling	396
6.7 Bit order of CRC and scrambler	398
6.8 Address frames	401
6.8.1 Address frames overview	401
6.8.2 IDENTIFY address frame	403
6.8.3 OPEN address frame	407
6.9 Link reset sequence	411
6.9.1 Link reset sequence overview	411
6.9.2 Expander device handling of link reset sequences	414
6.10 SL_IR (link layer identification and hard reset) state machines	414
6.10.1 SL_IR state machines overview	414
6.10.2 SL_IR transmitter and receiver	416
6.10.3 SL_IR_TIR (transmit IDENTIFY or HARD_RESET) state machine	416
6.10.3.1 SL_IR_TIR state machine overview	416
6.10.3.2 SL_IR_TIR1:Idle state	417
6.10.3.2.1 State description	417
6.10.3.2.2 Transition SL_IR_TIR1:Idle to SL_IR_TIR2:Transmit_Identify	417
6.10.3.2.3 Transition SL_IR_TIR1:Idle to SL_IR_TIR3:Transmit_Hard_Reset	417
6.10.3.3 SL_IR_TIR2:Transmit_Identify state	417
6.10.3.3.1 State description	417
6.10.3.3.2 Transition SL_IR_TIR2:Transmit_Identify to SL_IR_TIR4:Completed	417
6.10.3.4 SL_IR_TIR3:Transmit_Hard_Reset state	417
6.10.3.4.1 State description	417
6.10.3.4.2 Transition SL_IR_TIR3:Transmit_Hard_Reset to SL_IR_TIR4:Completed	417
6.10.3.5 SL_IR_TIR4:Completed state	418
6.10.4 SL_IR_RIF (receive IDENTIFY address frame) state machine	418
6.10.4.1 SL_IR_RIF state machine overview	418
6.10.4.2 SL_IR_RIF1:Idle state	418
6.10.4.2.1 State description	418
6.10.4.2.2 Transition SL_IR_RIF1:Idle to SL_IR_RIF2:Receive_Identify_Frame	418
6.10.4.3 SL_IR_RIF2:Receive_Identify_Frame state	418
6.10.4.3.1 State description	418
6.10.4.3.2 Transition SL_IR_RIF2:Receive_Identify_Frame to SL_IR_RIF3:Completed	419
6.10.4.4 SL_IR_RIF3:Completed state	419
6.10.5 SL_IR_IRC (identification and hard reset control) state machine	419
6.10.5.1 SL_IR_IRC state machine overview	419
6.10.5.2 SL_IR_IRC1:Idle state	419
6.10.5.2.1 State description	419
6.10.5.2.2 Transition SL_IR_IRC1:Idle to SL_IR_IRC2:Wait	419
6.10.5.3 SL_IR_IRC2:Wait state	419
6.10.5.3.1 State description	419
6.10.5.3.2 Transition SL_IR_IRC2:Wait to SL_IR_IRC3:Completed	420
6.10.5.4 SL_IR_IRC3:Completed state	420
6.11 Entering a low phy power condition	421
6.12 Power control and SL_P (link layer power control) state machines	421
6.12.1 Power source device	421
6.12.2 Power consumer device	422
6.12.3 NOTIFY (ENABLE SPINUP) usage	422
6.12.4 SL_P_S (link layer power source device) state machine	423
6.12.4.1 SL_P_S state machine overview	423
6.12.4.2 SL_P_S transmitter and SL_P_S receiver	424
6.12.4.3 SL_P_S_1:Idle state	425

This is a preview of "ISO/IEC 14776-263:20...". [Click here to purchase the full version from the ANSI store.](#)

6.12.4.4.1 State description	425
6.12.4.4.2 Transition SL_P_S_2:Wait_Grant to SL_P_S_1:Idle.....	426
6.12.4.4.3 Transition SL_P_S_2:Wait_Grant to SL_P_S_3:Wait_Done.....	426
6.12.4.5 SL_P_S_3:Wait_Done state.....	426
6.12.4.5.1 State description	426
6.12.4.5.2 Transition SL_P_S_3:Wait_Done to SL_P_S_1:Idle	427
6.12.5 SL_P_C (link layer power consumer device) state machine.....	427
6.12.5.1 SL_P_C state machine overview	427
6.12.5.2 SL_P_C receiver	429
6.12.5.3 SL_P_C_1:Idle state	429
6.12.5.3.1 State description	429
6.12.5.3.2 Transition SL_P_C_1:Idle to SL_P_C_2:Request_Power.....	429
6.12.5.4 SL_P_C_2:Request_Power state.....	429
6.12.5.4.1 State description	429
6.12.5.4.2 Transition SL_P_C_2:Request_Power to SL_P_C_1:Idle.....	430
6.12.5.4.3 Transition SL_P_C_2:Request_Power to SL_P_C_3:Wait_Grant	430
6.12.5.4.4 Transition SL_P_C_2:Request_Power to SL_P_C_4:Wait_Done.....	430
6.12.5.5 SL_P_C_3:Wait_Grant state.....	430
6.12.5.5.1 State description	430
6.12.5.5.2 Transition SL_P_C_3:Wait_Grant to SL_P_C_1:Idle	431
6.12.5.5.3 Transition SL_P_C_3:Wait_Grant to SL_P_C_4:Wait_Done	431
6.12.5.6 SL_P_C_4:Wait_Done state	431
6.12.5.6.1 State description	431
6.12.5.6.2 Transition SL_P_C_4:Wait_Done to SL_P_C_1:Idle.....	431
6.13 SAS domain changes (Broadcast (Change) usage).....	432
6.14 Connections.....	433
6.14.1 Connections overview.....	433
6.14.2 Opening a connection	433
6.14.2.1 Connection request	433
6.14.2.2 Results of a connection request.....	435
6.14.3 Arbitration fairness	435
6.14.4 Arbitration inside an expander device.....	436
6.14.4.1 Expander logical phy arbitration requirements	436
6.14.4.2 ECM arbitration requirements	437
6.14.4.2.1 ECM arbitration requirements overview.....	437
6.14.4.2.2 Arbitrating confirmations	438
6.14.4.2.3 Arb Won confirmation	438
6.14.4.2.4 Arb Lost confirmation	439
6.14.4.2.5 Arb Reject confirmation	439
6.14.4.3 Arbitration status	440
6.14.4.4 Partial Pathway Timeout timer	440
6.14.4.5 Pathway recovery.....	441
6.14.5 BREAK handling	441
6.14.6 Aborting a connection request.....	442
6.14.7 Expander device request for an SSP connection close.....	444
6.14.8 Closing a connection.....	444
6.14.9 Breaking a connection	445
6.15 Rate matching	446
6.16 SL (link layer for SAS logical phys) state machines	449
6.16.1 SL state machines overview	449
6.16.2 SL transmitter and receiver.....	452
6.16.3 SL_RA (receive OPEN address frame) state machine.....	454
6.16.4 SL_CC (connection control) state machine	454
6.16.4.1 SL_CC state machine overview	454

This is a preview of "ISO/IEC 14776-263:20...". [Click here to purchase the full version from the ANSI store.](#)

6.16.4.2.3 Transition SL_CC0:Idle to SL_CC2:Selected	458
6.16.4.2.4 Transition SL_CC0:Idle to SL_CC8:PS_Request	459
6.16.4.2.5 Transition SL_CC0:Idle to SL_CC9:PS_Quiet	459
6.16.4.3 SL_CC1:ArbSel state	459
6.16.4.3.1 State description	459
6.16.4.3.2 Transition SL_CC1:ArbSel to SL_CC0:Idle	461
6.16.4.3.3 Transition SL_CC1:ArbSel to SL_CC2:Selected	461
6.16.4.3.4 Transition SL_CC1:ArbSel to SL_CC3:Connected	461
6.16.4.3.5 Transition SL_CC1:ArbSel to SL_CC5:BreakWait	462
6.16.4.3.6 Transition SL_CC1:ArbSel to SL_CC6:Break	462
6.16.4.4 SL_CC2:Selected state	462
6.16.4.4.1 State description	462
6.16.4.4.2 Transition SL_CC2:Selected to SL_CC0:Idle	463
6.16.4.4.3 Transition SL_CC2:Selected to SL_CC3:Connected	463
6.16.4.4.4 Transition SL_CC2:Selected to SL_CC5:BreakWait	463
6.16.4.4.5 Transition SL_CC2:Selected to SL_CC6:Break	464
6.16.4.5 SL_CC3:Connected state	464
6.16.4.5.1 State description	464
6.16.4.5.2 Transition SL_CC3:Connected to SL_CC4:DisconnectWait	464
6.16.4.5.3 Transition SL_CC3:Connected to SL_CC5:BreakWait	465
6.16.4.5.4 Transition SL_CC3:Connected to SL_CC6:Break	465
6.16.4.5.5 Transition SL_CC3:Connected to SL_CC7:CloseSTP	465
6.16.4.6 SL_CC4:DisconnectWait state	465
6.16.4.6.1 State description	465
6.16.4.6.2 Transition SL_CC4:DisconnectWait to SL_CC0:Idle	465
6.16.4.6.3 Transition SL_CC4:DisconnectWait to SL_CC5:BreakWait	466
6.16.4.6.4 Transition SL_CC4:DisconnectWait to SL_CC6:Break	466
6.16.4.7 SL_CC5:BreakWait state	466
6.16.4.7.1 State description	466
6.16.4.7.2 Transition SL_CC5:BreakWait to SL_CC0:Idle	466
6.16.4.8 SL_CC6:Break state	466
6.16.4.8.1 State description	466
6.16.4.8.2 Transition SL_CC6:Break to SL_CC0:Idle	467
6.16.4.9 SL_CC7:CloseSTP state	467
6.16.4.9.1 State description	467
6.16.4.9.2 Transition SL_CC7:CloseSTP to SL_CC0:Idle	467
6.16.4.10 SL_CC8:PS_Request state	467
6.16.4.10.1 State description	467
6.16.4.10.2 Transition SL_CC8:PS_Request to SL_CC9:PS_Quiet	468
6.16.4.10.3 Transition SL_CC8:PS_Request to SL_CC0:Idle	468
6.16.4.10.4 Transition SL_CC8:PS_Request to SL_CC2:Selected	469
6.16.4.11 SL_CC9:PS_Quiet state	469
6.16.4.11.1 State description	469
6.16.4.11.2 Transition SL_CC9:PS_Quiet to SL_CC0:Idle	469
6.16.4.11.3 Transition SL_CC9:PS_Quiet to SL_CC1:ArbSel	469
6.17 XL (link layer for expander logical phys) state machine	470
6.17.1 XL state machine overview	470
6.17.2 XL transmitter and receiver	476
6.17.3 XL0:Idle state	478
6.17.3.1 State description	478
6.17.3.2 Transition XL0:Idle to XL1:Request_Path	479
6.17.3.3 Transition XL0:Idle to XL5:Forward_Open	479
6.17.3.3.1 Transition XL0:Idle to XL11:PS_Request	479
6.17.3.3.2 Transition XL0:Idle to XL12:PS_Quiet	480

This is a preview of "ISO/IEC 14776-263:20...". [Click here to purchase the full version from the ANSI store.](#)

6.17.4.3 Transition XL1:Request_Path to XL2:Request_Open.....	481
6.17.4.4 Transition XL1:Request_Path to XL4:Open_Reject.....	481
6.17.4.5 Transition XL1:Request_Path to XL5:Forward_Open.....	481
6.17.4.6 Transition XL1:Request_Path to XL9:Break.....	482
6.17.5 XL2:Request_Open state.....	482
6.17.5.1 State description.....	482
6.17.5.2 Transition XL2:Request_Open to XL3:Open_Confirm_Wait.....	482
6.17.6 XL3:Open_Confirm_Wait state.....	482
6.17.6.1 State description.....	482
6.17.6.2 Transition XL3:Open_Confirm_Wait to XL0:Idle.....	483
6.17.6.3 Transition XL3:Open_Confirm_Wait to XL1:Request_Path.....	483
6.17.6.4 Transition XL3:Open_Confirm_Wait to XL5:Forward_Open.....	483
6.17.6.5 Transition XL3:Open_Confirm_Wait to XL7:Connected.....	484
6.17.6.6 Transition XL3:Open_Confirm_Wait to XL9:Break.....	484
6.17.6.7 Transition XL3:Open_Confirm_Wait to XL10:Break_Wait.....	484
6.17.7 XL4:Open_Reject state.....	484
6.17.7.1 State description.....	484
6.17.7.2 Transition XL4:Open_Reject to XL0:Idle.....	484
6.17.7.3 Transition XL4:Open_Reject to XL5:Forward_Open.....	484
6.17.8 XL5:Forward_Open state.....	484
6.17.8.1 State description.....	484
6.17.8.2 Transition XL5:Forward_Open to XL6:Open_Response_Wait.....	485
6.17.9 XL6:Open_Response_Wait state.....	485
6.17.9.1 State description.....	485
6.17.9.2 Transition XL6:Open_Response_Wait to XL0:Idle.....	486
6.17.9.3 Transition XL6:Open_Response_Wait to XL1:Request_Path.....	486
6.17.9.4 Transition XL6:Open_Response_Wait to XL2:Request_Open.....	486
6.17.9.5 Transition XL6:Open_Response_Wait to XL7:Connected.....	487
6.17.9.6 Transition XL6:Open_Response_Wait to XL9:Break.....	487
6.17.9.7 Transition XL6:Open_Response_Wait to XL10:Break_Wait.....	487
6.17.10 XL7:Connected state.....	487
6.17.10.1 State description.....	487
6.17.10.2 Transition XL7:Connected to XL8:Close_Wait.....	488
6.17.10.3 Transition XL7:Connected to XL9:Break.....	488
6.17.10.4 Transition XL7:Connected to XL10:Break_Wait.....	488
6.17.11 XL8:Close_Wait state.....	489
6.17.11.1 State description.....	489
6.17.11.2 Transition XL8:Close_Wait to XL0:Idle.....	489
6.17.11.3 Transition XL8:Close_Wait to XL9:Break.....	489
6.17.11.4 Transition XL8:Close_Wait to XL10:Break_Wait.....	490
6.17.12 XL9:Break state.....	490
6.17.12.1 State description.....	490
6.17.12.2 Transition XL9:Break to XL0:Idle.....	490
6.17.13 XL10:Break_Wait state.....	490
6.17.13.1 State description.....	490
6.17.13.2 Transition XL10:Break_Wait to XL0:Idle.....	490
6.17.14 XL11:PS_Request state.....	490
6.17.14.1 State description.....	490
6.17.14.2 Transition XL11:PS_Request to XL12:PS_Quiet.....	491
6.17.14.3 Transition XL11:PS_Request to XL0:Idle.....	492
6.17.14.4 Transition XL11:PS_Request to XL1:Request_Path.....	492
6.17.15 XL12:PS_Quiet state.....	492
6.17.15.1 State description.....	492
6.17.15.2 Transition XL12:PS_Quiet to XL0:Idle.....	492

This is a preview of "ISO/IEC 14776-263:20...". [Click here to purchase the full version from the ANSI store.](#)

6.18.3 SSP frame transmission and reception.....	494
6.18.4 SSP flow control.....	494
6.18.5 Extending an SSP connection with persistent connections	495
6.18.6 Interlocked frames	495
6.18.7 Breaking an SSP connection	497
6.18.8 Closing an SSP connection	498
6.18.9 SSP (link layer for SSP phys) state machines	499
6.18.9.1 SSP state machines overview.....	499
6.18.9.2 SSP transmitter and receiver	503
6.18.9.3 SSP_TIM (transmit interlocked frame monitor) state machine.....	505
6.18.9.4 SSP_TCM (transmit frame credit monitor) state machine.....	505
6.18.9.5 SSP_D (DONE control) state machine.....	506
6.18.9.6 SSP_TF (transmit frame control) state machine	507
6.18.9.6.1 SSP_TF state machine overview.....	507
6.18.9.6.2 SSP_TF1:Connected_Idle state	508
6.18.9.6.2.1 State description	508
6.18.9.6.2.2 Transition SSP_TF1:Connected_Idle to SSP_TF2:Tx_Wait.....	508
6.18.9.6.2.3 Transition SSP_TF1:Connected_Idle to SSP_TF4:Transmit_DONE.....	508
6.18.9.6.3 SSP_TF2:Tx_Wait state	508
6.18.9.6.3.1 State description	508
6.18.9.6.3.2 Transition SSP_TF2:Tx_Wait to SSP_TF3:Transmit_Frame.....	509
6.18.9.6.3.3 Transition SSP_TF2:Tx_Wait to SSP_TF4:Transmit_DONE.....	509
6.18.9.6.4 SSP_TF3:Transmit_Frame state	509
6.18.9.6.4.1 State description	509
6.18.9.6.4.2 Transition SSP_TF3:Transmit_Frame to SSP_TF1:Connected_Idle.....	509
6.18.9.6.5 SSP_TF4:Transmit_DONE state.....	510
6.18.9.7 SSP_RF (receive frame control) state machine.....	510
6.18.9.8 SSP_RCM (receive frame credit monitor) state machine.....	511
6.18.9.9 SSP_RIM (receive interlocked frame monitor) state machine.....	512
6.18.9.10 SSP_TC (transmit credit control) state machine	512
6.18.9.11 SSP_TAN (transmit ACK/NAK control) state machine.....	512
6.18.9.12 SSP_EM (establish and manage persistent connection) state machine.....	513
6.18.9.12.1 SSP_EM state machine overview.....	513
6.18.9.12.2 SSP_EM1:Establish state.....	513
6.18.9.12.3 Transition SSP_EM1:Establish to SSP_EM2:Manage	514
6.18.9.12.4 SSP_EM2:Manage	514
6.18.9.12.5 Transition SSP_EM2:Manage to SSP_EM1:Establish	514
6.19 STP link layer	515
6.19.1 STP frame transmission and reception.....	515
6.19.2 STP flow control.....	515
6.19.2.1 STP flow control overview	515
6.19.2.2 SATA frame buffering.....	515
6.19.2.3 STP flow control buffer size.....	516
6.19.2.4 STP flow control example.....	517
6.19.2.5 STP insufficient buffer support	519
6.19.3 Continued primitive sequence.....	519
6.19.4 Affiliations.....	520
6.19.5 Opening an STP connection	522
6.19.6 Closing an STP connection.....	525
6.19.7 STP connection management examples	525
6.19.8 STP (link layer for STP phys) state machines	528
6.19.9 SMP target port support.....	528
6.20 SMP link layer.....	528
6.20.1 SMP frame transmission and reception	528

This is a preview of "ISO/IEC 14776-263:20...". [Click here to purchase the full version from the ANSI store.](#)

6.20.5 SMP (link layer for SMP phys) state machines.....	529
6.20.5.1 SMP state machines overview	529
6.20.5.2 SMP transmitter and receiver.....	529
6.20.5.3 SMP_IP (link layer for SMP initiator phys) state machine	530
6.20.5.3.1 SMP_IP state machine overview	530
6.20.5.3.2 SMP_IP1:Idle state	531
6.20.5.3.2.1 State description	531
6.20.5.3.2.2 Transition SMP_IP1:Idle to SMP_IP2:Transmit_Frame.....	531
6.20.5.3.3 SMP_IP2:Transmit_Frame state	531
6.20.5.3.3.1 State description	531
6.20.5.3.3.2 Transition SMP_IP2:Transmit_Frame to SMP_IP3:Receive_Frame	531
6.20.5.3.4 SMP_IP3:Receive_Frame state	531
6.20.5.4 SMP_TP (link layer for SMP target phys) state machine	532
6.20.5.4.1 SMP_TP state machine overview.....	532
6.20.5.4.2 SMP_TP1:Receive_Frame state	533
6.20.5.4.2.1 State description	533
6.20.5.4.2.2 Transition SMP_TP1:Receive_Frame to SMP_TP2:Transmit_Frame.....	534
6.20.5.4.3 SMP_TP2:Transmit_Frame state	534
7 Port layer.....	535
7.1 Port layer overview	535
7.2 PL (port layer) state machines.....	535
7.2.1 PL state machines overview	535
7.2.2 PL_OC (port layer overall control) state machine	537
7.2.2.1 PL_OC state machine overview	537
7.2.2.2 PL_OC1:Idle state	539
7.2.2.2.1 PL_OC1:Idle state description	539
7.2.2.2.2 Transition PL_OC1:Idle to PL_OC2:Overall_Control.....	540
7.2.2.3 PL_OC2:Overall_Control state.....	540
7.2.2.3.1 PL_OC2:Overall_Control state overview	540
7.2.2.3.2 PL_OC2: Non-connection specific confirmations and requests.....	540
7.2.2.3.2.1 PL_OC2: Transmit Frame request	540
7.2.2.3.2.2 PL_OC2: HARD_RESET Received confirmation.....	541
7.2.2.3.2.3 PL_OC2: Notify Received (Power Loss Expected) confirmation	541
7.2.2.3.2.4 PL_OC2: Phy Disabled confirmation.....	541
7.2.2.3.2.5 PL_OC2: Start I_T Nexus Loss Timer request.....	542
7.2.2.3.3 PL_OC2:Overall_Control state establishing connections.....	542
7.2.2.3.4 PL_OC2:Overall_Control state connection established.....	546
7.2.2.3.5 PL_OC2:Overall_Control state unable to establish a connection — Unable To Connect message.....	546
7.2.2.3.6 PL_OC2:Overall_Control state unable to establish a connection — Unable To Connect message - Retry Open message processed as an Unable To Connect message	546
7.2.2.3.7 PL_OC2:Overall_Control state unable to establish a connection — I_T Nexus Loss timer expires	547
7.2.2.3.8 PL_OC2:Overall_Control state - I_T nexus loss event	547
7.2.2.3.9 PL_OC2:Overall_Control state connection management.....	547
7.2.2.3.10 PL_OC2:Overall_Control state frame transmission.....	549
7.2.2.3.11 PL_OC2:Overall_Control state frame transmission cancellations	550
7.2.2.3.12 Transition PL_OC2:Overall_Control to PL_OC1:Idle.....	550
7.2.3 PL_PM (port layer phy manager) state machine	551
7.2.3.1 PL_PM state machine overview	551
7.2.3.2 PL_PM1:Idle state	554
7.2.3.2.1 PL_PM1:Idle state description	554
7.2.3.2.2 Transition PL_PM1:Idle to PL_PM2:Req_Wait.....	554

This is a preview of "ISO/IEC 14776-263:20...". [Click here to purchase the full version from the ANSI store.](#)

7.2.3.3.2 PL_PM2:Req_Wait establishing a connection.....	554
7.2.3.3.3 PL_PM2:Req_Wait connection established.....	555
7.2.3.3.4 PL_PM2:Req_Wait unable to establish a connection.....	555
7.2.3.3.5 PL_PM2:Req_Wait connection management.....	557
7.2.3.3.6 Transition PL_PM2:Req_Wait to PL_PM1:Idle.....	557
7.2.3.3.7 Transition PL_PM2:Req_Wait to PL_PM3:Connected.....	557
7.2.3.3.8 Transition PL_PM2:Req_Wait to PL_PM4:Wait_For_Close.....	557
7.2.3.4 PL_PM3:Connected state.....	557
7.2.3.4.1 PL_PM3:Connected state description.....	557
7.2.3.4.2 Transition PL_PM3:Connected to PL_PM1:Idle.....	561
7.2.3.5 PL_PM4:Wait_For_Close state.....	561
7.2.3.5.1 PL_PM4:Wait_For_Close state description.....	561
7.2.3.5.2 Transition PL_PM4:Wait_For_Close to PL_PM1:Idle.....	561
8 Transport layer.....	562
8.1 Transport layer overview.....	562
8.2 SSP transport layer.....	563
8.2.1 SSP frame format.....	563
8.2.2 Information units.....	567
8.2.2.1 COMMAND frame - Command information unit.....	567
8.2.2.2 TASK frame - Task Management Function information unit.....	568
8.2.2.3 XFER_RDY frame - Transfer Ready information unit.....	571
8.2.2.4 DATA frame - Data information unit.....	572
8.2.2.5 RESPONSE frame - Response information unit.....	574
8.2.2.5.1 RESPONSE frame - Response information unit overview.....	574
8.2.2.5.2 Response information unit - NO_DATA format.....	575
8.2.2.5.3 Response information unit - RESPONSE_DATA format.....	575
8.2.2.5.4 Response information unit - SENSE_DATA format.....	576
8.2.3 Sequences of SSP frames.....	577
8.2.3.1 Sequences of SSP frames overview.....	577
8.2.3.2 Task management function sequence of SSP frames.....	578
8.2.3.3 Non-data command sequence of SSP frames.....	578
8.2.3.4 Write command sequence of SSP frames.....	579
8.2.3.5 Read command sequence of SSP frames.....	579
8.2.3.6 Bidirectional command sequence of SSP frames.....	580
8.2.4 SSP transport layer handling of link layer errors.....	580
8.2.4.1 SSP transport layer handling of link layer errors overview.....	580
8.2.4.2 COMMAND frame - handling of link layer errors.....	581
8.2.4.3 TASK frame - handling of link layer errors.....	582
8.2.4.4 XFER_RDY frame - handling of link layer errors.....	582
8.2.4.4.1 XFER_RDY frame overview.....	582
8.2.4.4.2 XFER_RDY frame with transport layer retries enabled.....	582
8.2.4.4.3 XFER_RDY frame with transport layer retries disabled.....	583
8.2.4.5 Read DATA frame - handling of link layer errors.....	583
8.2.4.5.1 Read DATA frame overview.....	583
8.2.4.5.2 Read DATA frame with transport layer retries enabled.....	583
8.2.4.5.3 Read DATA frame with transport layer retries disabled.....	584
8.2.4.6 Write DATA frame - handling of link layer errors.....	584
8.2.4.6.1 Write DATA frame overview.....	584
8.2.4.6.2 Write DATA frame with transport layer retries enabled.....	584
8.2.4.6.3 Write DATA frame with transport layer retries disabled.....	585
8.2.4.7 RESPONSE frame - handling of link layer errors.....	585
8.2.5 SSP transport layer error handling summary.....	585
8.2.5.1 SSP transport layer error handling summary introduction.....	585

This is a preview of "ISO/IEC 14776-263:20...". [Click here to purchase the full version from the ANSI store.](#)

8.2.6.1 ST state machines overview	587
8.2.6.2 ST_I (transport layer for SSP initiator ports) state machines	588
8.2.6.2.1 ST_I state machines overview	588
8.2.6.2.2 ST_IFR (initiator frame router) state machine	590
8.2.6.2.2.1 ST_IFR state machine overview	590
8.2.6.2.2.2 Processing transport protocol service requests	590
8.2.6.2.2.3 Processing Frame Received confirmations.....	591
8.2.6.2.2.4 Processing Transmission Complete and Reception Complete messages.....	592
8.2.6.2.2.5 Processing miscellaneous requests.....	593
8.2.6.2.3 ST_ITS (initiator transport server) state machine	594
8.2.6.2.3.1 ST_ITS state machine overview	594
8.2.6.2.3.2 ST_ITS1:Initiator_Start state.....	595
8.2.6.2.3.2.1 State description.....	595
8.2.6.2.3.2.2 Transition ST_ITS1:Initiator_Start to ST_ITS3:Prepare_Command.....	595
8.2.6.2.3.2.3 Transition ST_ITS1:Initiator_Start to ST_ITS4:Prepare_Task	595
8.2.6.2.3.3 ST_ITS2:Initiator_Send_Frame state.....	595
8.2.6.2.3.3.1 Transition ST_ITS2:Initiator_Send_Frame to ST_ITS1:Initiator_Start	599
8.2.6.2.3.3.2 Transition ST_ITS2:Initiator_Send_Frame to ST_ITS5:Prepare_Data_Out.....	599
8.2.6.2.3.3.3 Transition ST_ITS2:Initiator_Send_Frame to ST_ITS6:Receive_Data_In	600
8.2.6.2.3.4 ST_ITS3:Prepare_Command state.....	600
8.2.6.2.3.4.1 State description.....	600
8.2.6.2.3.4.2 Transition ST_ITS3:Prepare_Command to ST_ITS2:Initiator_Send_Frame	600
8.2.6.2.3.5 ST_ITS4:Prepare_Task state.....	601
8.2.6.2.3.5.1 State description.....	601
8.2.6.2.3.5.2 Transition ST_ITS4:Prepare_Task to ST_ITS2:Initiator_Send_Frame	601
8.2.6.2.3.6 ST_ITS5:Prepare_Data_Out state	601
8.2.6.2.3.6.1 State description.....	601
8.2.6.2.3.6.2 Transition ST_ITS5:Prepare_Data_Out to ST_ITS2:Initiator_Send_Frame	602
8.2.6.2.3.7 ST_ITS6:Receive_Data_In state.....	602
8.2.6.2.3.7.1 State description.....	602
8.2.6.2.3.7.2 Transition ST_ITS6:Receive_Data_In to ST_ITS1:Initiator_Start	604
8.2.6.2.3.7.3 Transition ST_ITS6:Receive_Data_In to ST_ITS2:Initiator_Send_Frame	604
8.2.6.3 ST_T (transport layer for SSP target ports) state machines	604
8.2.6.3.1 ST_T state machines overview.....	604
8.2.6.3.2 ST_TFR (target frame router) state machine.....	606
8.2.6.3.2.1 ST_TFR state machine overview	606
8.2.6.3.2.2 Processing Frame Received confirmations.....	606
8.2.6.3.2.3 Processing transport protocol service requests and responses.....	608
8.2.6.3.2.4 Processing miscellaneous requests and confirmations	612
8.2.6.3.3 ST_TTS (target transport server) state machine	612
8.2.6.3.3.1 ST_TTS state machine overview	612
8.2.6.3.3.2 ST_TTS1:Target_Start state	613
8.2.6.3.3.2.1 State description.....	613
8.2.6.3.3.2.2 Transition ST_TTS1:Target_Start to ST_TTS3:Prepare_Data_In.....	614
8.2.6.3.3.2.3 Transition ST_TTS1:Target_Start to ST_TTS4:Prepare_Xfer_Rdy	614
8.2.6.3.3.2.4 Transition ST_TTS1:Target_Start to ST_TTS5:Receive_Data_Out.....	614
8.2.6.3.3.2.5 Transition ST_TTS1:Target_Start to ST_TTS7:Prepare_Response	614
8.2.6.3.3.3 ST_TTS2:Target_Send_Frame state.....	614
8.2.6.3.3.3.1 State description.....	614
8.2.6.3.3.3.2 Transition ST_TTS2:Target_Send_Frame to ST_TTS1:Target_Start.....	618
8.2.6.3.3.3.3 Transition ST_TTS2:Target_Send_Frame to ST_TTS3:Prepare_Data_In	618
8.2.6.3.3.3.4 Transition ST_TTS2:Target_Send_Frame to ST_TTS5:Receive_Data_Out	618
8.2.6.3.3.4 ST_TTS3:Prepare_Data_In state.....	619
8.2.6.3.3.4.1 State description.....	619

This is a preview of "ISO/IEC 14776-263:20...". [Click here to purchase the full version from the ANSI store.](#)

8.2.6.3.3.5.2 Transition ST_TTS4:Prepare_Xfer_Rdy to ST_TTS2:Target_Send_Frame	621
8.2.6.3.3.6 ST_TTS5:Receive_Data_Out state.....	621
8.2.6.3.3.6.1 State description.....	621
8.2.6.3.3.6.2 Transition ST_TTS5:Receive_Data_Out to ST_TTS1:Target_Start.....	622
8.2.6.3.3.6.3 Transition ST_TTS5:Receive_Data_Out to ST_TTS4:Prepare_Xfer_Rdy.....	622
8.2.6.3.3.7 ST_TTS6:Prepare_Response state	623
8.2.6.3.3.7.1 State description.....	623
8.2.6.3.3.7.2 Transition ST_TTS6:Prepare_Response to ST_TTS2:Target_Send_Frame.....	624
8.3 STP transport layer.....	624
8.3.1 Initial FIS	624
8.3.2 BIST Activate FIS.....	625
8.3.3 TT (transport layer for STP ports) state machines.....	625
8.4 SMP transport layer.....	625
8.4.1 SMP transport layer overview	625
8.4.2 SMP_REQUEST frame.....	626
8.4.3 SMP_RESPONSE frame.....	626
8.4.4 Sequence of SMP frames.....	627
8.4.5 MT (transport layer for SMP ports) state machines	627
8.4.5.1 SMP transport layer state machines overview	627
8.4.5.2 MT_IP (transport layer for SMP initiator ports) state machine	627
8.4.5.2.1 MT_IP state machine overview.....	627
8.4.5.2.2 MT_IP1:Idle state.....	628
8.4.5.2.2.1 State description	628
8.4.5.2.2.2 Transition MT_IP1:Idle to MT_IP2:Send	628
8.4.5.2.3 MT_IP2:Send state	629
8.4.5.2.3.1 State description	629
8.4.5.2.3.2 Transition MT_IP2:Send to MT_IP1:Idle	629
8.4.5.2.3.3 Transition MT_IP2:Send to MT_IP3:Receive	629
8.4.5.2.4 MT_IP3:Receive state	629
8.4.5.2.4.1 State description	629
8.4.5.2.4.2 Transition MT_IP3:Receive to MT_IP1:Idle	629
8.4.5.3 MT_TP (transport layer for SMP target ports) state machine.....	630
8.4.5.3.1 MT_TP state machine overview	630
8.4.5.3.2 MT_TP1:Idle state	630
8.4.5.3.2.1 State description	630
8.4.5.3.2.2 Transition MT_TP1:Idle to MT_TP2:Respond.....	631
8.4.5.3.3 MT_TP2:Respond state.....	631
8.4.5.3.3.1 State description	631
8.4.5.3.3.2 Transition MT_TP2:Respond to MT_TP1:Idle.....	631
9 Application layer.....	632
9.1 Application layer overview	632
9.2 SCSI application layer	632
9.2.1 SCSI transport protocol services	632
9.2.1.1 SCSI transport protocol services overview.....	632
9.2.1.2 Send SCSI Command transport protocol service.....	634
9.2.1.3 SCSI Command Received transport protocol service	635
9.2.1.4 Send Command Complete transport protocol service.....	636
9.2.1.5 Command Complete Received transport protocol service	637
9.2.1.6 Send Data-In transport protocol service.....	638
9.2.1.7 Data-In Delivered transport protocol service	639
9.2.1.8 Receive Data-Out transport protocol service	639
9.2.1.9 Data-Out Received transport protocol service	640
9.2.1.10 Terminate Data Transfer transport protocol service.....	641

This is a preview of "ISO/IEC 14776-263:20...". [Click here to purchase the full version from the ANSI store.](#)

9.2.1.14 Task Management Function Executed transport protocol service	643
9.2.1.15 Received Task Management Function Executed transport protocol service	644
9.2.2 SCSI application client error handling	645
9.2.3 SCSI device server error handling	646
9.2.3.1 SCSI Command Received () error handling	646
9.2.3.2 Data-Out Received () error handling	646
9.2.4 Task router and task manager error handling	647
9.2.5 SCSI transport protocol services for event notifications	647
9.2.6 SCSI commands	648
9.2.6.1 INQUIRY command.....	648
9.2.6.2 LOG SELECT and LOG SENSE commands	648
9.2.6.3 MODE SELECT and MODE SENSE commands	648
9.2.6.4 SEND DIAGNOSTIC and RECEIVE DIAGNOSTIC RESULTS commands.....	648
9.2.6.5 START STOP UNIT command.....	648
9.2.7 SCSI mode parameters	649
9.2.7.1 SCSI mode parameters overview.....	649
9.2.7.2 Disconnect-Reconnect mode page	649
9.2.7.2.1 Disconnect-Reconnect mode page overview	649
9.2.7.2.2 BUS INACTIVITY LIMIT field	651
9.2.7.2.3 CONNECT TIME LIMIT field.....	651
9.2.7.2.4 MAXIMUM BURST SIZE field	651
9.2.7.2.5 FIRST BURST SIZE field.....	652
9.2.7.3 Protocol Specific Logical Unit mode page.....	652
9.2.7.4 Protocol Specific Port mode page	653
9.2.7.5 Phy Control And Discover mode page	655
9.2.7.6 Shared Port Control mode page.....	659
9.2.7.7 Enhanced Phy Control mode page	660
9.2.8 SCSI log parameters.....	663
9.2.8.1 Protocol Specific Port log page	663
9.2.8.2 Protocol Specific Port log parameter for SAS target ports	665
9.2.9 SCSI diagnostic parameters	668
9.2.9.1 SCSI diagnostic parameters overview	668
9.2.9.2 Protocol Specific diagnostic page	669
9.2.9.3 Enclosure Control diagnostic page.....	675
9.2.9.4 Enclosure Status diagnostic page	675
9.2.9.5 Additional Element Status diagnostic page	676
9.2.10 SCSI power conditions.....	676
9.2.10.1 SCSI power conditions overview.....	676
9.2.10.2 SA_PC (SCSI application layer power condition) state machine	676
9.2.10.2.1 SA_PC state machine overview	676
9.2.10.2.2 SA_PC_0:Powered_On state	680
9.2.10.2.2.1 State description	680
9.2.10.2.2.2 Transition SA_PC_0:Powered_On to SA_PC_4:Active_Wait.....	680
9.2.10.2.2.3 Transition SA_PC_0:Powered_On to SA_PC_8:Stopped	680
9.2.10.2.3 SA_PC_1:Active state	680
9.2.10.2.3.1 State description	680
9.2.10.2.3.2 Transition SA_PC_1:Active to SA_PC_5:Wait_Idle	680
9.2.10.2.3.3 Transition SA_PC_1:Active to SA_PC_6:Wait_Standby.....	680
9.2.10.2.3.4 Transition SA_PC_1:Active to SA_PC_10:Wait_Stopped	680
9.2.10.2.4 SA_PC_2:Idle state	680
9.2.10.2.4.1 State description	680
9.2.10.2.4.2 Transition SA_PC_2:Idle to SA_PC_4:Active_Wait.....	680
9.2.10.2.4.3 Transition SA_PC_2:Idle to SA_PC_5:Wait_Idle.....	681
9.2.10.2.4.4 Transition SA_PC_2:Idle to SA_PC_6:Wait_Standby.....	681

This is a preview of "ISO/IEC 14776-263:20...". [Click here to purchase the full version from the ANSI store.](#)

9.2.10.2.5.1 State description	681
9.2.10.2.5.2 Transition SA_PC_3:Standby to SA_PC_4:Active_Wait.....	681
9.2.10.2.5.3 Transition SA_PC_3:Standby to SA_PC_6:Wait_Standby	681
9.2.10.2.5.4 Transition SA_PC_3:Standby to SA_PC_7:Idle_Wait.....	681
9.2.10.2.5.5 Transition SA_PC_3:Standby to SA_PC_9: Standby_Wait	681
9.2.10.2.5.6 Transition SA_PC_3:Standby to SA_PC_10:Wait_Stopped	682
9.2.10.2.6 SA_PC_4:Active_Wait state	682
9.2.10.2.6.1 State description	682
9.2.10.2.6.2 Transition SA_PC_4:Active_Wait to SA_PC_1:Active	684
9.2.10.2.7 SA_PC_5:Wait_Idle state	684
9.2.10.2.7.1 SA_PC_5:Wait_Idle state description	684
9.2.10.2.7.2 Transition SA_PC_5:Wait_Idle to SA_PC_2:Idle	684
9.2.10.2.8 SA_PC_6:Wait_Standby state.....	684
9.2.10.2.8.1 SA_PC_6:Wait_Standby state description.....	684
9.2.10.2.8.2 Transition SA_PC_6:Wait_Standby to SA_PC_3:Standby	684
9.2.10.2.9 SA_PC_7:Idle_Wait state	684
9.2.10.2.9.1 State description	684
9.2.10.2.9.2 Transition SA_PC_7:Idle_Wait to SA_PC_2:Idle	686
9.2.10.2.10 SA_PC_8:Stopped state.....	686
9.2.10.2.10.1 State description	686
9.2.10.2.10.2 Transition SA_PC_8:Stopped to SA_PC_4:Active_Wait	686
9.2.10.2.10.3 Transition SA_PC_8:Stopped to SA_PC_7:Idle_Wait	686
9.2.10.2.10.4 Transition SA_PC_8:Stopped to SA_PC_9:Standby_Wait	686
9.2.10.2.11 SA_PC_9:Standby_Wait state.....	686
9.2.10.2.11.1 SA_PC_9:Standby_Wait state description.....	686
9.2.10.2.11.2 Transition SA_PC_9:Standby_Wait to SA_PC_3:Standby	686
9.2.10.2.12 SA_PC_10:Wait_Stopped state.....	686
9.2.10.2.12.1 SA_PC_10:Wait_Stopped state description.....	686
9.2.10.2.12.2 Transition SA_PC_10:Wait_Stopped to SA_PC_8:Stopped.....	686
9.2.11 SCSI vital product data (VPD)	687
9.2.11.1 SCSI vital product data (VPD) overview.....	687
9.2.11.2 Device Identification VPD page.....	687
9.2.11.3 Protocol Specific Logical Unit Information VPD page	688
9.2.11.4 Protocol Specific Port Information VPD page.....	690
9.3 ATA application layer.....	693
9.4 Management application layer.....	693
9.4.1 READY LED signal behavior	693
9.4.2 Management protocol services	695
9.4.3 SMP functions.....	695
9.4.3.1 SMP functions overview	695
9.4.3.2 SMP function request frame format.....	698
9.4.3.2.1 SMP function request frame format overview.....	698
9.4.3.2.2 SMP FRAME TYPE field	698
9.4.3.2.3 FUNCTION field	698
9.4.3.2.4 ALLOCATED RESPONSE LENGTH field	698
9.4.3.2.5 REQUEST LENGTH field.....	699
9.4.3.2.6 Additional request bytes	699
9.4.3.2.7 CRC field	700
9.4.3.3 SMP function response frame format.....	700
9.4.3.3.1 SMP function response frame format overview	700
9.4.3.3.2 SMP FRAME TYPE field	701
9.4.3.3.3 FUNCTION field	701
9.4.3.3.4 FUNCTION RESULT field	701
9.4.3.3.5 RESPONSE LENGTH field	709

This is a preview of "ISO/IEC 14776-263:20...". [Click here to purchase the full version from the ANSI store.](#)

9.4.3.5 REPORT MANUFACTURER INFORMATION function	717
9.4.3.6 REPORT SELF-CONFIGURATION STATUS function	721
9.4.3.6.1 REPORT SELF-CONFIGURATION STATUS function overview	721
9.4.3.6.2 REPORT SELF-CONFIGURATION STATUS request	721
9.4.3.6.3 REPORT SELF-CONFIGURATION STATUS response	723
9.4.3.6.4 Self-configuration status descriptor	725
9.4.3.7 REPORT ZONE PERMISSION TABLE function.....	727
9.4.3.7.1 REPORT ZONE PERMISSION TABLE function overview	727
9.4.3.7.2 REPORT ZONE PERMISSION TABLE request.....	728
9.4.3.7.3 REPORT ZONE PERMISSION TABLE response	730
9.4.3.7.4 Zone permission descriptor	731
9.4.3.8 REPORT ZONE MANAGER PASSWORD function.....	732
9.4.3.9 REPORT BROADCAST function	735
9.4.3.9.1 REPORT BROADCAST function overview.....	735
9.4.3.9.2 REPORT BROADCAST request	735
9.4.3.9.3 REPORT BROADCAST response.....	737
9.4.3.9.4 Broadcast descriptor	738
9.4.3.10 DISCOVER function	740
9.4.3.11 REPORT PHY ERROR LOG function.....	758
9.4.3.12 REPORT PHY SATA function	761
9.4.3.13 REPORT ROUTE INFORMATION function	765
9.4.3.14 REPORT PHY EVENT function	768
9.4.3.14.1 REPORT PHY EVENT function overview.....	768
9.4.3.14.2 REPORT PHY EVENT request	769
9.4.3.14.3 REPORT PHY EVENT response.....	770
9.4.3.14.4 Phy event descriptor	771
9.4.3.15 DISCOVER LIST function	772
9.4.3.15.1 DISCOVER LIST function overview.....	772
9.4.3.15.2 DISCOVER LIST request	773
9.4.3.15.3 DISCOVER LIST response.....	775
9.4.3.15.4 DISCOVER LIST response SHORT FORMAT descriptor	777
9.4.3.16 REPORT PHY EVENT LIST function.....	778
9.4.3.16.1 REPORT PHY EVENT LIST function overview	778
9.4.3.16.2 REPORT PHY EVENT LIST request.....	778
9.4.3.16.3 REPORT PHY EVENT LIST response	779
9.4.3.16.4 Phy event list descriptor.....	781
9.4.3.17 REPORT EXPANDER ROUTE TABLE LIST function	781
9.4.3.17.1 REPORT EXPANDER ROUTE TABLE LIST function overview.....	781
9.4.3.17.2 REPORT EXPANDER ROUTE TABLE LIST request	782
9.4.3.17.3 REPORT EXPANDER ROUTE TABLE LIST response.....	784
9.4.3.17.4 Expander route table descriptor.....	786
9.4.3.18 CONFIGURE GENERAL function	786
9.4.3.19 ENABLE DISABLE ZONING function	790
9.4.3.20 ZONED BROADCAST function.....	793
9.4.3.21 ZONE LOCK function	796
9.4.3.22 ZONE ACTIVATE function	799
9.4.3.23 ZONE UNLOCK function.....	800
9.4.3.24 CONFIGURE ZONE MANAGER PASSWORD function	802
9.4.3.25 CONFIGURE ZONE PHY INFORMATION function.....	805
9.4.3.25.1 CONFIGURE ZONE PHY INFORMATION function overview.....	805
9.4.3.25.2 CONFIGURE ZONE PHY INFORMATION request.....	806
9.4.3.25.3 Zone phy configuration descriptor	808
9.4.3.25.4 CONFIGURE ZONE PHY INFORMATION response.....	808
9.4.3.26 CONFIGURE ZONE PERMISSION TABLE function	809

This is a preview of "ISO/IEC 14776-263:20...". [Click here to purchase the full version from the ANSI store.](#)

9.4.3.26.4 CONFIGURE ZONE PERMISSION TABLE response	813
9.4.3.27 CONFIGURE ROUTE INFORMATION function	814
9.4.3.28 PHY CONTROL function	817
9.4.3.29 PHY TEST FUNCTION function.....	826
9.4.3.30 CONFIGURE PHY EVENT function.....	830
9.4.3.30.1 CONFIGURE PHY EVENT function overview	830
9.4.3.30.2 CONFIGURE PHY EVENT request.....	831
9.4.3.30.3 Phy event configuration descriptor	832
9.4.3.30.4 CONFIGURE PHY EVENT response	833
Annex A (normative) Jitter tolerance patterns.....	834
A.1 Jitter tolerance pattern (JTPAT).....	834
A.2 Compliant jitter tolerance pattern (CJTPAT)	834
A.3 Considerations for a phy transmitting JTPAT and CJTPAT	842
A.4 Considerations for a phy receiving JTPAT and CJTPAT	842
Annex B (informative) SAS to SAS phy reset sequence examples	844
Annex C (informative) CRC.....	849
C.1 CRC generator and checker implementation examples	849
C.2 CRC implementation in C	849
C.3 CRC implementation with XORs.....	851
C.4 CRC examples.....	852
Annex D (informative) SAS address hashing.....	853
D.1 SAS address hashing overview	853
D.2 Hash collision probability	853
D.3 Hash generation.....	854
D.4 Hash implementation in C.....	854
D.5 Hash implementation with XORs	855
D.6 Hash examples	856
Annex E (informative) Scrambling.....	860
E.1 Scrambler implementation example.....	860
E.2 Scrambler implementation in C	860
E.3 Scrambler implementation with XORs	861
E.4 Scrambler examples	862
Annex F (informative) ATA architectural notes	865
F.1 STP differences from Serial ATA (SATA).....	865
F.2 STP differences from Serial ATA II	865
F.3 Affiliation policies.....	865
F.3.1 Affiliation policies overview	865
F.3.2 Affiliation policy for static STP initiator port to STP target port mapping	866
F.3.3 Affiliation policy with SATA queued commands and multiple STP initiator ports.....	866
F.3.4 Applicability of affiliation for STP target ports	866
F.4 SATA port selector considerations	866
F.5 SATA device not transmitting initial Register Device-to-Host FIS	867
Annex G (informative) Minimum deletable primitive insertion rate summary	868
Annex H (informative) Zone permission configuration descriptor examples	869
Annex I (informative) SAS addressing	872

This is a preview of "ISO/IEC 14776-263:20...". [Click here to purchase the full version from the ANSI store.](#)

Annex J (informative) Expander device handling of connections.....	873
J.1 Expander device handling of connections overview	873
J.2 Connection request - OPEN_ACCEPT.....	875
J.3 Connection request - OPEN_REJECT by end device.....	876
J.4 Connection request - OPEN_REJECT by expander device	877
J.5 Connection request - arbitration lost.....	878
J.6 Connection request - backoff and retry.....	879
J.7 Connection request - backoff and reverse path.....	880
J.8 Connection close - single step.....	881
J.9 Connection close - simultaneous.....	882
J.10 BREAK handling during path arbitration when the BREAK_REPLY method is disabled	883
J.11 BREAK handling during connection when the BREAK_REPLY method is disabled	884
J.12 BREAK handling during path arbitration when the BREAK_REPLY method is enabled	885
J.13 BREAK handling during connection when BREAK_REPLY method is enabled.....	886
J.14 STP connection - originated by STP initiator port.....	887
J.15 STP connection - originated by STP target port in an STP SATA bridge	888
J.16 STP connection close - originated by STP initiator port	889
J.17 STP connection close - originated by STP target port in an STP SATA bridge.....	890
J.18 Connection request - XL1:Request_Path to XL5:Forward_Open transition	891
J.19 Pathway blocked and pathway recovery example	892
Annex K (informative) Primitive encoding	894
Annex L (informative) Standards bodies contact information.....	897
Annex M (informative) Successful low phy power condition handshake sequence	898
Bibliography	901

This is a preview of "ISO/IEC 14776-263:20...". [Click here to purchase the full version from the ANSI store.](#)

Table 4 — Class diagram notation for classes.....	83
Table 5 — Multiplicity notation	84
Table 6 — Class diagram notation for associations.....	85
Table 7 — Class diagram notation for aggregations.....	86
Table 8 — Class diagram notation for generalizations	86
Table 9 — Class diagram notation for dependency.....	87
Table 10 — Object diagram notation for objects.....	88
Table 11 — Object diagram notation for link.....	88
Table 12 — Data dword containing a value	92
Table 13 — Data dword containing four one-byte fields	92
Table 14 — Logical links.....	100
Table 15 — Broadcast types.....	116
Table 16 — Names and identifiers.....	119
Table 17 — SCSI architecture model object attribute mapping	119
Table 18 — NAA IEEE Registered format	120
Table 19 — NAA Locally Assigned format.....	121
Table 20 — Hashed SAS address code parameters	122
Table 21 — Device name created from the IDENTIFY (PACKET) DEVICE world wide name.....	123
Table 22 — Expander logical phy to ECM requests	147
Table 23 — Expander logical phy to ECM responses.....	147
Table 24 — ECM to expander logical phy confirmations	148
Table 25 — Expander logical phy to ECR to expander logical phy requests and indications.....	149
Table 26 — Expander logical phy to ECR to expander logical phy responses and confirmations.....	149
Table 27 — Expander logical phy to BPP requests	151
Table 28 — BPP to expander logical phy indications	152
Table 29 — Routing attributes and routing methods.....	152
Table 30 — Expander route table types.....	154
Table 31 — Expander route table levels for externally configurable expander device R phy A.....	166
Table 32 — Expander route table levels for externally configurable expander device N.....	167
Table 33 — Expander route entries for externally configurable expander device E0 phy 1	168
Table 34 — Expander route entries for externally configurable expander device F phy 0.....	169
Table 35 — Zone manager password.....	174
Table 36 — Zone phy information.....	177
Table 37 — Zone phy information usage	178
Table 38 — Zone groups	179
Table 39 — Zone permission table	181
Table 40 — Zone permission table granting minimal permissions.....	182
Table 41 — Source zone group determination	184
Table 42 — Destination zone group determination.....	184
Table 43 — REQUESTED INSIDE ZPSDS bit and INSIDE ZPSDS PERSISTENT bit changes after a link reset sequence	185
Table 44 — ZONE GROUP field values if the ZONE GROUP PERSISTENT bit is set to one	186
Table 45 — Conditions that cause the ZONE GROUP field to be updated if the ZONE GROUP PERSISTENT bit is set to zero.....	187
Table 46 — PHY EVENT SOURCE field	196
Table 47 — Bit designations	202
Table 48 — Conversion from byte notation to character name example.....	203
Table 49 — Data characters	205
Table 50 — Control characters	210
Table 51 — Control character usage	211
Table 52 — Delayed code violation example.....	212
Table 53 — SNW-3 phy capabilities	218
Table 54 — Requested logical link rate	219
Table 55 — Multiplexing negotiation	220

This is a preview of "ISO/IEC 14776-263:20...". [Click here to purchase the full version from the ANSI store.](#)

Table 59 — Train_Tx-SNW TTIU	226
Table 60 — PATTERN TYPE field	226
Table 61 — Control/Status TTIU	227
Table 62 — COEFFICIENT SETTINGS field	227
Table 63 — COEFFICIENT 1 REQUEST field, COEFFICIENT 2 REQUEST field, and COEFFICIENT 3 REQUEST field	228
Table 64 — Valid coefficient requests	229
Table 65 — COEFFICIENT 1 STATUS field, COEFFICIENT 2 STATUS field, and COEFFICIENT 3 STATUS field	230
Table 66 — Error Response TTIU	230
Table 67 — ERROR CODE field	232
Table 68 — Phy reset sequence timing specifications	233
Table 69 — SATA speed negotiation sequence timing specifications	235
Table 70 — SAS speed negotiation sequence timing specifications	240
Table 71 — SNW rates used in SNW-1, SNW-2, and Final-SNW	243
Table 72 — SNW-3 phy capabilities bit	244
Table 73 — Transmitter training pattern	246
Table 74 — Receiver training patterns	249
Table 75 — SP state machine timers	280
Table 76 — Messages to SP transmitter and SP receiver at start of RCDT	292
Table 77 — SP_DWS state machine timers	313
Table 78 — Mapping messages to the Training Control word	329
Table 79 — Mapping messages from PTT_SC1 state machine, PTT_SC2 state machine, and PTT_SC3 state machine to the Training Status word	329
Table 80 — Mapping Transmit Error Response message arguments to Error Response TTIU fields	330
Table 81 — Transmit Error Response message arguments sent to PTT_T state machine	336
Table 82 — Mapping the Training Status word to SP receiver messages	337
Table 83 — Mapping the Training Status word to PTT_GC1 state machine messages, PTT_GC2 state machine messages, and PTT_GC3 state machine messages	338
Table 84 — Mapping the Training Control word to PTT_SC1 state machine messages, PTT_SC2 state machine messages, and PTT_SC3 state machine messages	339
Table 85 — Mapping Coefficient Request byte to PTT_SC3 state machine message, PTT_SC2 state machine message, and PTT_SC1 state machine messages	340
Table 86 — Mapping messages to the PTT_T state machine	344
Table 87 — PTT_SC1 messages to substitute for PTT_SC2 messages	345
Table 88 — PTT_SC1 messages to substitute for PTT_SC3 messages	346
Table 89 — Mapping messages to the PTT_T state machine	348
Table 90 — PTT_GC1 messages to substitute for PTT_GC2 messages	349
Table 91 — PTT_GC1 messages to substitute for PTT_GC2 messages	349
Table 92 — Primitive format	356
Table 93 — Deletable primitives	357
Table 94 — Primitives not specific to type of connection	358
Table 95 — Primitives used inside SSP and SMP connections	362
Table 96 — Primitives used inside STP connections and on SATA physical links	364
Table 97 — Primitive encoding for deletable primitives	366
Table 98 — Primitive encoding for primitives not specific to type of connection	367
Table 99 — Primitive encoding for primitives used only inside SSP and SMP connections	369
Table 100 — Primitive encoding for primitives used only inside STP connections and only on SATA physical links	370
Table 101 — Primitive sequences	371
Table 102 — ALIGN primitives	376
Table 103 — MUX primitives	377
Table 104 — NOTIFY primitives	377
Table 105 — AIP primitives	379
Table 106 — BROADCAST primitives	380
Table 107 — CLOSE primitives	381

This is a preview of "ISO/IEC 14776-263:20...". [Click here to purchase the full version from the ANSI store.](#)

Table 111 — DONE primitives	386
Table 112 — NAK primitives	387
Table 113 — RRDY primitives	387
Table 114 — Physical link rate tolerance management deletable primitive insertion requirement	390
Table 115 — CRC notation and definitions	392
Table 116 — Scrambling for different data dword types	396
Table 117 — Address frame format	402
Table 118 — ADDRESS FRAME TYPE field	402
Table 119 — IDENTIFY address frame format	403
Table 120 — DEVICE TYPE field	404
Table 121 — REASON field	404
Table 122 — POWER CAPABLE field	406
Table 123 — OPEN address frame format	407
Table 124 — SAS PROTOCOL field	408
Table 125 — FEATURES field	408
Table 126 — CONNECTION RATE field	408
Table 127 — ARBITRATION WAIT TIME field	410
Table 128 — SL_IR_IRC state machine timers	414
Table 129 — PS_ACK pattern	421
Table 130 — SL_P_S state machine timers	423
Table 131 — SL_P_C state machine timers	427
Table 132 — Connection results of a connection request	435
Table 133 — Arbitration priority for OPEN address frames passing on a logical link	436
Table 134 — Arbitration priority for a Request Path request in the ECM	439
Table 135 — Pathway recovery priority	441
Table 136 — Results of aborting a connection request	442
Table 137 — Results of closing a connection	445
Table 138 — Results of breaking a connection	446
Table 139 — Rate matching deletable primitive insertion requirements	447
Table 140 — SL_CC state machine timers	456
Table 141 — SL_CC state machine variables	456
Table 142 — OPEN_REJECT Received message to Open Failed confirmation mapping	460
Table 143 — XL state machine timers	471
Table 144 — XL state machine variable	471
Table 145 — SSP frame interlock requirements	495
Table 146 — SSP state machines timers	500
Table 147 — SSP state machines timers for persistent connections	500
Table 148 — STP link layer differences from SATA link layer during an STP connection	515
Table 149 — Affiliation policies	521
Table 150 — Affiliation context relative identifier example	522
Table 151 — PL_OC state machine timers	538
Table 152 — Confirmations from Unable To Connect messages	546
Table 153 — PL_PM state machine timers	551
Table 154 — Messages from Open Failed confirmations	555
Table 155 — SSP frame format	563
Table 156 — FRAME TYPE field	564
Table 157 — TLR CONTROL field for COMMAND frames	565
Table 158 — COMMAND frame - Command information unit	567
Table 159 — TASK ATTRIBUTE field	568
Table 160 — TASK frame - Task Management Function information unit	569
Table 161 — TASK MANAGEMENT FUNCTION field	570
Table 162 — XFER_RDY frame - Transfer Ready information unit	572
Table 163 — DATA frame - Data information unit	573
Table 164 — RESPONSE frame - Response information unit	574

This is a preview of "ISO/IEC 14776-263:20...". [Click here to purchase the full version from the ANSI store.](#)

Table 168 — Sequences of SSP frames	577
Table 169 — Confirmations sent to the SCSI application layer if a frame transmission error or reception error occurs.....	593
Table 170 — ST_ITS state machine variables.....	594
Table 171 — ST_ITS state machine arguments.....	595
Table 172 — Messages sent to the ST_IFR state machine.....	597
Table 173 — Transmission Complete messages for XFER_RDY frame verification failures	598
Table 174 — Reception Complete messages for read DATA frame verification failures.....	603
Table 175 — ST_T state machine timers.....	604
Table 176 — Task Management Function Executed Service Response argument mapping to Request (Send Transport Response) Service Response argument.....	609
Table 177 — Confirmations sent to the SCSI application layer	611
Table 178 — ST_TTS state machine variables	613
Table 179 — ST_TTS state machine arguments.....	613
Table 180 — Messages sent to the ST_TFR state machine	617
Table 181 — Additional messages sent to the ST_TFR state machine.....	618
Table 182 — Reception Complete message for write DATA frame verification failures	621
Table 183 — Request (Send Transport Response) message Service Response argument to RESPONSE frame RESPONSE DATA field mapping.....	624
Table 184 — SMP frame format	625
Table 185 — SMP FRAME TYPE field	625
Table 186 — SMP_REQUEST frame format.....	626
Table 187 — SMP_RESPONSE frame format	626
Table 188 — MT_TP time limits.....	630
Table 189 — Execute Command procedure call transport protocol services	633
Table 190 — Task management function procedure call transport protocol services	634
Table 191 — Send SCSI Command transport protocol service arguments.....	635
Table 192 — SCSI Command Received transport protocol service arguments	636
Table 193 — Send Command Complete transport protocol service arguments.....	637
Table 194 — Command Complete Received transport protocol service arguments	638
Table 195 — Send Data-In transport protocol service arguments	639
Table 196 — Data-In Delivered transport protocol service arguments	639
Table 197 — Receive Data-Out transport protocol service arguments.....	640
Table 198 — Data-Out Received transport protocol service arguments.....	640
Table 199 — Terminate Data Transfer transport protocol service arguments	641
Table 200 — Data Transfer Terminated transport protocol service arguments.....	641
Table 201 — Send Task Management Request transport protocol service arguments.....	642
Table 202 — Task Management Request Received transport protocol service arguments	643
Table 203 — Task Management Function Executed transport protocol service arguments.....	644
Table 204 — Received Task Management Function Executed transport protocol service arguments.....	645
Table 205 — Delivery Result to additional sense code mapping.....	647
Table 206 — SCSI transport protocol events.....	648
Table 207 — SSP target port mode pages	649
Table 208 — Disconnect-Reconnect mode page for SAS SSP.....	650
Table 209 — Protocol Specific Logical Unit mode page for SAS SSP	653
Table 210 — Protocol Specific Port mode page for SAS SSP.....	654
Table 211 — I_T NEXUS LOSS TIME field	655
Table 212 — Phy Control And Discover mode page	656
Table 213 — SAS phy mode descriptor.....	658
Table 214 — Shared Port Control mode page.....	659
Table 215 — Enhanced Phy Control mode page.....	661
Table 216 — Enhanced phy control mode descriptor	662
Table 217 — Protocol Specific Port log parameters	663
Table 218 — Protocol Specific Port log page for SAS SSP.....	664

This is a preview of "ISO/IEC 14776-263:20...". [Click here to purchase the full version from the ANSI store.](#)

Table 222 — Diagnostic pages affected by zoning.....	669
Table 223 — Protocol Specific diagnostic page for SAS SSP.....	670
Table 224 — PHY TEST FUNCTION field.....	671
Table 225 — PHY TEST PATTERN field.....	672
Table 226 — PHY TEST FUNCTION SSC field.....	673
Table 227 — PHY TEST FUNCTION PHYSICAL LINK RATE field.....	673
Table 228 — PHY TEST PATTERN DWORDS CONTROL field.....	674
Table 229 — TWO_DWORDS phy test pattern examples.....	675
Table 230 — Summary of states in the SA_PC state machine.....	677
Table 231 — VPD pages with special requirements for SAS SSP.....	687
Table 232 — Device Identification VPD page designation descriptors for the SAS target port.....	687
Table 233 — Device Identification VPD page designation descriptors for the SAS target device.....	688
Table 234 — Protocol Specific Logical Unit Information VPD page for SAS SSP.....	689
Table 235 — Logical unit information descriptor for SAS SSP.....	690
Table 236 — Protocol Specific Port Information VPD page for SAS SSP.....	691
Table 237 — Port information descriptor for SAS SSP.....	692
Table 238 — SAS phy information descriptor for SAS SSP.....	693
Table 239 — READY LED signal behavior.....	694
Table 240 — SMP functions (FUNCTION field).....	695
Table 241 — SMP request frame format.....	698
Table 242 — SMP response frame format.....	700
Table 243 — FUNCTION RESULT field.....	701
Table 244 — Function result priority.....	705
Table 245 — REPORT GENERAL request.....	710
Table 246 — REPORT GENERAL response.....	711
Table 247 — NUMBER OF ZONE GROUPS field.....	715
Table 248 — REPORT MANUFACTURER INFORMATION request.....	717
Table 249 — REPORT MANUFACTURER INFORMATION response.....	719
Table 250 — REPORT SELF-CONFIGURATION STATUS request.....	721
Table 251 — REPORT SELF-CONFIGURATION STATUS response.....	723
Table 252 — Self-configuration status descriptor.....	725
Table 253 — STATUS TYPE field.....	725
Table 254 — REPORT ZONE PERMISSION TABLE request.....	728
Table 255 — REPORT TYPE field.....	729
Table 256 — REPORT ZONE PERMISSION TABLE response.....	730
Table 257 — Zone permission descriptors.....	731
Table 258 — Zone permission descriptor for a source zone group (i.e., s) with 128 zone groups.....	731
Table 259 — Zone permission descriptor for a source zone group (i.e., s) with 256 zone groups.....	732
Table 260 — Zone permission descriptor bit requirements.....	732
Table 261 — REPORT ZONE MANAGER PASSWORD request.....	733
Table 262 — REPORT TYPE field.....	734
Table 263 — REPORT ZONE MANAGER PASSWORD response.....	734
Table 264 — REPORT BROADCAST request.....	735
Table 265 — REPORT BROADCAST response.....	737
Table 266 — Broadcast descriptor.....	738
Table 267 — BROADCAST REASON field for originated Broadcasts.....	739
Table 268 — DISCOVER request.....	740
Table 269 — DISCOVER response.....	741
Table 270 — ATTACHED DEVICE TYPE field.....	744
Table 271 — NEGOTIATED LOGICAL LINK RATE field and NEGOTIATED PHYSICAL LINK RATE field.....	746
Table 272 — NEGOTIATED PHYSICAL LINK RATE field and NEGOTIATED LOGICAL LINK RATE field combinations based on multiplexing.....	747
Table 273 — ATTACHED SATA PORT SELECTOR and ATTACHED SATA DEVICE bits.....	748
Table 274 — PROGRAMMED MINIMUM PHYSICAL LINK RATE field and PROGRAMMED MAXIMUM PHYSICAL	

This is a preview of "ISO/IEC 14776-263:20...". [Click here to purchase the full version from the ANSI store.](#)

Table 276 — ROUTING ATTRIBUTE field	752
Table 277 — PHY POWER CONDITION field	753
Table 278 — SAS POWER CAPABLE field	753
Table 279 — PWR_DIS SIGNAL field	754
Table 280 — PWR_DIS CONTROL CAPABLE field	754
Table 281 — ATTACHED DEVICE NAME field	755
Table 282 — SELF-CONFIGURATION STATUS field	756
Table 283 — SELF-CONFIGURATION LEVELS COMPLETED field	756
Table 284 — REPORT PHY ERROR LOG request	759
Table 285 — REPORT PHY ERROR LOG response	760
Table 286 — REPORT PHY SATA request	762
Table 287 — REPORT PHY SATA response	763
Table 288 — REPORT ROUTE INFORMATION request	765
Table 289 — REPORT ROUTE INFORMATION response	767
Table 290 — REPORT PHY EVENT request	769
Table 291 — REPORT PHY EVENT response	770
Table 292 — Phy event descriptor	771
Table 293 — DISCOVER LIST request	773
Table 294 — PHY FILTER field	774
Table 295 — DESCRIPTOR TYPE field	774
Table 296 — DISCOVER LIST response	775
Table 297 — SHORT FORMAT descriptor	777
Table 298 — REPORT PHY EVENT LIST request	778
Table 299 — REPORT PHY EVENT LIST response	779
Table 300 — Phy event list descriptor	781
Table 301 — REPORT EXPANDER ROUTE TABLE LIST request	782
Table 302 — REPORT EXPANDER ROUTE TABLE LIST response	784
Table 303 — Expander route table descriptor	786
Table 304 — CONFIGURE GENERAL request	787
Table 305 — STP SMP I_T NEXUS LOSS TIME field	789
Table 306 — CONFIGURE GENERAL response	790
Table 307 — ENABLE DISABLE ZONING request	791
Table 308 — SAVE field	792
Table 309 — ENABLE DISABLE ZONING field	792
Table 310 — ENABLE DISABLE ZONING response	793
Table 311 — ZONED BROADCAST request	794
Table 312 — BROADCAST TYPE field	795
Table 313 — ZONED BROADCAST response	796
Table 314 — ZONE LOCK request	797
Table 315 — ZONE LOCK response	798
Table 316 — ZONE ACTIVATE request	799
Table 317 — ZONE ACTIVATE response	800
Table 318 — ZONE UNLOCK request	801
Table 319 — ZONE UNLOCK response	802
Table 320 — CONFIGURE ZONE MANAGER PASSWORD request	803
Table 321 — SAVE field	804
Table 322 — CONFIGURE ZONE MANAGER PASSWORD response	804
Table 323 — CONFIGURE ZONE PHY INFORMATION request	806
Table 324 — SAVE field	807
Table 325 — Zone phy configuration descriptor	808
Table 326 — CONFIGURE ZONE PHY INFORMATION response	808
Table 327 — CONFIGURE ZONE PERMISSION TABLE request	810
Table 328 — NUMBER OF ZONE GROUPS field	811
Table 329 — SAVE field	811

This is a preview of "ISO/IEC 14776-263:20...". [Click here to purchase the full version from the ANSI store.](#)

Table 333 — Zone permission configuration descriptor bit requirements	813
Table 334 — CONFIGURE ZONE PERMISSION TABLE response	813
Table 335 — CONFIGURE ROUTE INFORMATION request	815
Table 336 — CONFIGURE ROUTE INFORMATION response	816
Table 337 — PHY CONTROL request.....	818
Table 338 — PHY OPERATION field	820
Table 339 — PROGRAMMED MINIMUM PHYSICAL LINK RATE field and PROGRAMMED MAXIMUM PHYSICAL LINK RATE field	822
Table 340 — ENABLE SAS SLUMBER field	823
Table 341 — ENABLE SAS PARTIAL field	823
Table 342 — ENABLE SATA SLUMBER field	824
Table 343 — ENABLE SATA PARTIAL field	824
Table 344 — PWR_DIS CONTROL field	825
Table 345 — PHY CONTROL response.....	825
Table 346 — PHY TEST FUNCTION request	827
Table 347 — PHY TEST FUNCTION field	829
Table 348 — PHY TEST FUNCTION PHYSICAL LINK RATE field	829
Table 349 — PHY TEST FUNCTION response.....	830
Table 350 — CONFIGURE PHY EVENT request.....	831
Table 351 — Phy event configuration descriptor	832
Table 352 — CONFIGURE PHY EVENT response.....	833
Table A.1 — JTPAT for RD+ and RD-	834
Table A.2 — CJTPAT.....	836
Table A.3 — CJTPAT with fixed content.....	841
Table C.1 — CRC examples	852
Table D.1 — Monte-Carlo simulation results	854
Table D.2 — Hash results for simple SAS addresses.....	856
Table D.3 — Hash results for realistic SAS addresses.....	856
Table D.4 — Hash results for a walking ones pattern.....	857
Table D.5 — Hash results for a walking zeros pattern.....	858
Table E.1 — Scrambler examples	862
Table E.2 — Initial scrambler output.....	863
Table G.1 — Minimum deletable primitive insertion rate examples	868
Table H.1 — Zone permission table example initial value	869
Table H.2 — CONFIGURE ZONE PERMISSION TABLE request example.....	869
Table H.3 — Zone permission table after processing first zone permission configuration descriptor.....	870
Table H.4 — Zone permission table after processing second zone permission configuration descriptor.....	871
Table J.1 — Column descriptions for connection examples	873
Table K.1 — Primitives with Hamming distance of at least 7.....	894
Table K.2 — Primitives without Hamming distance of 7	896
Table L.1 — Standards bodies.....	897

This is a preview of "ISO/IEC 14776-263:20...". [Click here to purchase the full version from the ANSI store.](#)

Figure 4 — Examples of association relationships in class diagrams	85
Figure 5 — Examples of aggregation relationships in class diagrams	86
Figure 6 — Example of generalization relationships in class diagrams	87
Figure 7 — Example of a dependency relationship in class diagrams	87
Figure 8 — Examples of link relationships for object diagrams	89
Figure 9 — State machine conventions	90
Figure 10 — SAS Domain class diagram	95
Figure 11 — Phy class diagram	97
Figure 12 — SAS phy object diagram	98
Figure 13 — Expander phy object diagram	99
Figure 14 — Ports (narrow ports and wide ports)	101
Figure 15 — Port class diagram	102
Figure 16 — Port object diagram	103
Figure 17 — SAS devices	105
Figure 18 — Expander device	106
Figure 19 — Domains	107
Figure 20 — SAS domain bridging to ATA domains	108
Figure 21 — SAS domains bridging to ATA domains with SATA port selectors	109
Figure 22 — Devices spanning SAS domains	110
Figure 23 — Single expander device topology example	111
Figure 24 — Multiple expander device topologies and routing methods	112
Figure 25 — Potential pathways	113
Figure 26 — Multiple connections on wide ports	115
Figure 27 — State machines for SAS devices	125
Figure 28 — State machines for expander devices	126
Figure 29 — Transmit data path in a SAS phy	127
Figure 30 — SSP link, port, SSP transport, and SCSI application layer state machines	128
Figure 31 — SMP link, port, SMP transport, and management application layer state machines	129
Figure 32 — STP link, port, STP transport, and ATA application layer state machines	130
Figure 33 — Transmit data path and state machines in an expander phy	131
Figure 34 — Receive data path in a SAS phy	133
Figure 35 — Receive data path in an expander phy	134
Figure 36 — State machines and SAS Device classes	135
Figure 37 — State machines and Expander Device classes	136
Figure 38 — Reset terminology	138
Figure 39 — Expander device model	142
Figure 40 — Expander device interfaces	145
Figure 41 — Expander device interface detail	146
Figure 42 — Phy-based expander route table	154
Figure 43 — Expander-based expander route table	155
Figure 44 — Level-order traversal example	158
Figure 45 — Examples of invalid topologies	162
Figure 46 — Externally configurable expander device and table-to-table attachment	165
Figure 47 — Expander route index levels example	166
Figure 48 — Expander route index order example	168
Figure 49 — Zoning example	170
Figure 50 — One ZPSDS example	171
Figure 51 — Zone manager location examples	172
Figure 52 — Three ZPSDSes example	173
Figure 53 — Extending a ZPSDS example	175
Figure 54 — Overtaking a ZPSDS example	176
Figure 55 — Zoning expander route table	183
Figure 56 — SAS bit transmission logic	213
Figure 57 — SAS bit reception logic	214

This is a preview of "ISO/IEC 14776-263:20...". [Click here to purchase the full version from the ANSI store.](#)

Figure 61 — TTIU bit cell transmitter encoding	224
Figure 62 — TTIU bit cell receiver decoding	225
Figure 63 — SATA OOB sequence	234
Figure 64 — SATA speed negotiation sequence	234
Figure 65 — SAS to SATA OOB sequence	236
Figure 66 — SAS to SAS OOB sequence	238
Figure 67 — SNW-1, SNW-2, and Final-SNW	242
Figure 68 — SNW-3	244
Figure 69 — Train_Tx-SNW	245
Figure 70 — Pattern marker transmission	247
Figure 71 — Valid pattern marker detection	248
Figure 72 — Train_Rx-SNW	249
Figure 73 — SAS speed negotiation sequence SNW flowchart	251
Figure 74 — SAS speed negotiation sequence (both phys SNW-1 through Train_Rx-SNW with no Train_Tx-SNW)	253
Figure 75 — SAS speed negotiation sequence (both phys SNW-1 through Train_Rx-SNW with Train_Tx-SNW)	254
Figure 76 — SAS speed negotiation sequence (phy A: SNW-1 through SNW-3, phy B: SNW-2 only)	255
Figure 77 — SAS speed negotiation sequence (phy A: SNW-3 only, phy B: SNW-1 only)	256
Figure 78 — SAS speed negotiation sequence - phy reset problem in Final-SNW	257
Figure 79 — SAS speed negotiation sequence - phy reset problem in SNW-3	258
Figure 80 — SAS speed negotiation sequence - phy reset problem in Train_Rx-SNW	259
Figure 81 — SAS speed negotiation sequence - multiple Train_Rx-SNWs	260
Figure 82 — Local phy achieves pattern lock before the attached phy achieves pattern lock	262
Figure 83 — Local phy achieves pattern lock after the attached phy achieves pattern lock	263
Figure 84 — Attached receiver handshake sequence (requesting two increments to coefficient 1)	265
Figure 85 — Attached receiver handshake sequence (requesting a decrement and an increment to coefficient 1)	266
Figure 86 — Handshake sequence to set local phy's receiver coefficients to no_equalization values (attached phy)	268
Figure 87 — Handshake sequence to set local phy's receiver coefficients to no_equalization values (local phy)	269
Figure 88 — Local phy's receiver indicates completion of training before the attached phy's receiver completes training	270
Figure 89 — Attached phy's receiver indicates completion of training before the local phy's receiver completes training	271
Figure 90 — Processing an invalid TTIU	273
Figure 91 — Hot-plug and the phy reset sequence	275
Figure 92 — Transition to active phy power condition	276
Figure 93 — Hot plug and low phy power condition	277
Figure 94 — SP (phy layer) state machine - OOB sequence states	283
Figure 95 — SP (phy layer) state machine - SAS speed negotiation states	290
Figure 96 — SP (phy layer) state machine - SAS speed negotiation states for SNW-3 and Train_Rx-SNW and Train_Tx-SNW	291
Figure 97 — SP (phy layer) state machine - SAS phy power condition states	303
Figure 98 — SP (phy layer) state machine - SATA host emulation states	306
Figure 99 — SP (phy layer) state machine – SATA port selector state	311
Figure 100 — SP (phy layer) state machine - SATA spinup hold state	312
Figure 101 — SP_DWS (phy layer dword synchronization) state machine	314
Figure 102 — PTT_T (phy layer transmitter training transmit pattern) state machine	326
Figure 103 — PTT_R (phy layer transmitter training receive pattern) state machine	334
Figure 104 — PTT_SC1, PTT_SC2, and PTT_SC3 (phy layer transmitter training set transmitter coefficient) state machines	342
Figure 105 — PTT_GC1, PTT_GC2, and PTT_GC3 (phy layer transmitter training get transmitter	

This is a preview of "ISO/IEC 14776-263:20...". [Click here to purchase the full version from the ANSI store.](#)

Figure 108 — Multiplexing enabled	355
Figure 109 — Transmitting a repeated primitive sequence	372
Figure 110 — Receiving a repeated primitive sequence	372
Figure 111 — Extended primitive sequences	373
Figure 112 — Triple primitive sequences	374
Figure 113 — Redundant primitive sequences	375
Figure 114 — Elasticity buffer	389
Figure 115 — Address frame, SSP frame, and SMP frame CRC bit ordering	394
Figure 116 — STP frame CRC bit ordering	395
Figure 117 — Transmit path bit ordering	398
Figure 118 — Receive path bit ordering	399
Figure 119 — STP transmit path bit ordering	400
Figure 120 — STP receive path bit ordering	401
Figure 121 — Address frame transmission	402
Figure 122 — Identification sequence	412
Figure 123 — Hard reset sequence	413
Figure 124 — SL_IR (link layer identification and hard reset) state machines	415
Figure 125 — Transitioning from the active phy power condition to a low phy power condition	421
Figure 126 — SL_P_S (link layer power source device) state machine	424
Figure 127 — SL_P_C (link layer power consumer device) state machine	428
Figure 128 — Example simultaneous connection recommendations for wide ports	434
Figure 129 — Aborting a connection request with a BREAK primitive sequence	443
Figure 130 — Connection request timeout example	444
Figure 131 — Closing a connection example	445
Figure 132 — Rate matching example	448
Figure 133 — SL (link layer for SAS logical phys) state machines (part 1)	450
Figure 134 — SL (link layer for SAS logical phys) state machines (part 2)	451
Figure 135 — SL (link layer for SAS logical phys) state machines (part 3)	452
Figure 136 — XL (link layer for expander logical phys) state machine (part 1)	472
Figure 137 — XL (link layer for expander logical phys) state machine (part 2)	473
Figure 138 — XL (link layer for expander logical phys) state machine (part 3)	474
Figure 139 — XL (link layer for expander logical phys) state machine (part 4)	475
Figure 140 — SSP frame transmission	494
Figure 141 — Interlocked frames	496
Figure 142 — Non-interlocked frames with the same initiator port transfer tags	497
Figure 143 — Non-interlocked frames with different initiator port transfer tags	497
Figure 144 — Closing an SSP connection example	499
Figure 145 — SSP (link layer for SSP phys) state machines (part 1 - frame transmission)	501
Figure 146 — SSP (link layer for SSP phys) state machines (part 2 - frame reception)	502
Figure 147 — SSP (link layer for SSP phys) state machines (part 3 - persistent connection)	503
Figure 148 — STP frame transmission	515
Figure 149 — STP flow control	518
Figure 150 — Transmitting a continued primitive sequence	520
Figure 151 — Receiving a continued primitive sequence	520
Figure 152 — Example simultaneous connection recommendations for an expander device	524
Figure 153 — STP initiator port opening an STP connection	526
Figure 154 — STP target port opening an STP connection	527
Figure 155 — SMP frame transmission	528
Figure 156 — SMP_IP (link layer for SMP initiator phys) state machine	530
Figure 157 — SMP_TP (link layer for SMP target phys) state machine	533
Figure 158 — Port layer examples	536
Figure 159 — PL_OC (port layer overall control) state machine	539
Figure 160 — PL_PM (port layer phy manager) state machine (part 1)	552
Figure 161 — PL_PM (port layer phy manager) state machine (part 2)	553

This is a preview of "ISO/IEC 14776-263:20...". [Click here to purchase the full version from the ANSI store.](#)

Figure 165 — Read command sequence of SSP frames	579
Figure 166 — Bidirectional command sequence of SSP frames	580
Figure 167 — ST_I (transport layer for SSP initiator ports) state machines	589
Figure 168 — ST_T (transport layer for SSP target ports) state machines	605
Figure 169 — Sequence of SMP frames	627
Figure 170 — MT_IP (transport layer for SMP initiator ports) state machine	628
Figure 171 — MT_TP (transport layer for SMP target ports) state machine	630
Figure 172 — SA_PC (SCSI application layer power condition) state machine for SAS	679
Figure A.1 — CJTPAT pre-scrambling	835
Figure B.1 — SAS speed negotiation sequence (phy A: SNW-1 only, phy B: SNW-1 only)	844
Figure B.2 — SAS speed negotiation sequence (phy A: SNW-1, SNW-2, phy B: SNW-1, SNW-2)	845
Figure B.3 — SAS speed negotiation sequence (phy A: SNW-1, SNW-2, and SNW-3, phy B: SNW-1 and SNW-2)	846
Figure B.4 — SAS speed negotiation sequence (phy A: SNW-2, SNW-3, phy B: SNW-1, SNW-2)	847
Figure B.5 — SAS speed negotiation sequence (phy A: SNW-1 only, phy B: SNW-2 only)	848
Figure C.1 — CRC generator example	849
Figure C.2 — CRC checker example	849
Figure D.1 — BCH(69, 39, 9) code generator	854
Figure E.1 — Scrambler	860
Figure J.1 — Example topology	873
Figure J.2 — Connection request - OPEN_ACCEPT	875
Figure J.3 — Connection request - OPEN_REJECT by end device	876
Figure J.4 — Connection request - OPEN_REJECT by expander device	877
Figure J.5 — Connection request - arbitration lost	878
Figure J.6 — Connection request - backoff and retry	879
Figure J.7 — Connection request - backoff and reverse path	880
Figure J.8 — Connection close - single step	881
Figure J.9 — Connection close - simultaneous	882
Figure J.10 — BREAK handling during path arbitration when the BREAK_REPLY method is disabled	883
Figure J.11 — BREAK handling during a connection when the BREAK_REPLY method is disabled	884
Figure J.12 — BREAK handling during path arbitration when the BREAK_REPLY method is enabled	885
Figure J.13 — BREAK handling during a connection when the BREAK_REPLY method is enabled	886
Figure J.14 — STP connection - originated by STP initiator port	887
Figure J.15 — STP connection - originated by STP target port in an STP SATA bridge	888
Figure J.16 — STP connection close - originated by STP initiator port	889
Figure J.17 — STP connection close - originated by STP target port in an STP SATA bridge	890
Figure J.18 — XL1:Request_Path to XL5:Forward_Open transition	891
Figure J.19 — Partial pathway recovery	892
Figure M.1 — Example of a requesting SAS device's sequencing of a successful request for entering a partial phy power condition	899
Figure M.2 — Example of a SAS device's sequencing for a successful request to enter a partial phy power condition	900

This is a preview of "ISO/IEC 14776-263:20...". [Click here to purchase the full version from the ANSI store.](#)

Part 263: SAS Protocol Layer - 3 (SPL-3)

FOREWORD

- 1) ISO (the International Organization for Standardization) and IEC (the International Electrotechnical Commission) form the specialized system for worldwide standardization. National bodies that are members of ISO or IEC participate in the development of International Standards through technical committees established by the respective organization to deal with particular fields of technical activity. ISO and IEC technical committees collaborate in fields of mutual interest. Other international organizations, governmental and non-governmental, in liaison with ISO and IEC, also take part in the work. In the field of information technology, ISO and IEC have established a joint technical committee, ISO/IEC JTC 1.
- 2) The formal decisions or agreements of IEC and ISO on technical matters express, as nearly as possible, an international consensus of opinion on the relevant subjects since each technical committee has representation from all interested IEC National Committees and ISO member bodies.
- 3) IEC, ISO and ISO/IEC publications have the form of recommendations for international use and are accepted by IEC National Committees and ISO member bodies in that sense. While all reasonable efforts are made to ensure that the technical content of IEC, ISO and ISO/IEC publications is accurate, IEC or ISO cannot be held responsible for the way in which they are used or for any misinterpretation by any end user.
- 4) In order to promote international uniformity, IEC National Committees and ISO member bodies undertake to apply IEC, ISO and ISO/IEC publications transparently to the maximum extent possible in their national and regional publications. Any divergence between any ISO, IEC or ISO/IEC publication and the corresponding national or regional publication should be clearly indicated in the latter.
- 5) ISO and IEC do not provide any attestation of conformity. Independent certification bodies provide conformity assessment services and, in some areas, access to IEC marks of conformity. ISO or IEC are not responsible for any services carried out by independent certification bodies.
- 6) All users should ensure that they have the latest edition of this publication.
- 7) No liability shall attach to IEC or ISO or its directors, employees, servants or agents including individual experts and members of their technical committees and IEC National Committees or ISO member bodies for any personal injury, property damage or other damage of any nature whatsoever, whether direct or indirect, or for costs (including legal fees) and expenses arising out of the publication of, use of, or reliance upon, this ISO/IEC publication or any other IEC, ISO or ISO/IEC publications.
- 8) Attention is drawn to the normative references cited in this publication. Use of the referenced publications is indispensable for the correct application of this publication.
- 9) Attention is drawn to the possibility that some of the elements of this ISO/IEC publication may be the subject of patent rights. ISO and IEC shall not be held responsible for identifying any or all such patent rights.

International Standard ISO/IEC 14776-263 was prepared by subcommittee 25: Interconnection of information technology equipment, of ISO/IEC joint technical committee 1: Information technology.

The list of all currently available parts of the ISO/IEC 14776 series, under the general title *Information technology – Small computer system interface (SCSI)*, can be found on the IEC web site.

This International Standard has been approved by vote of the member bodies and the voting results may be obtained from the address given on the second title page.

This publication has been drafted in accordance with the ISO/IEC Directives, Part 2 except as described in 3.4 and 3.5.

This is a preview of "ISO/IEC 14776-263:20...". [Click here to purchase the full version from the ANSI store.](#)

it contains colours which are considered to be useful for the correct understanding of its contents. Users should therefore print this document using a colour printer.

This is a preview of "ISO/IEC 14776-263:20...". Click here to purchase the full version from the ANSI store.

The SCSI family of standards provides for many different transport protocols that define the rules for exchanging information between different SCSI devices. This document defines the rules for exchanging information between SCSI devices using a serial interconnect. Other SCSI transport protocol standards define the rules for exchanging information between SCSI devices using other interconnects.

Figure 1 shows the organization of the layers of this document.

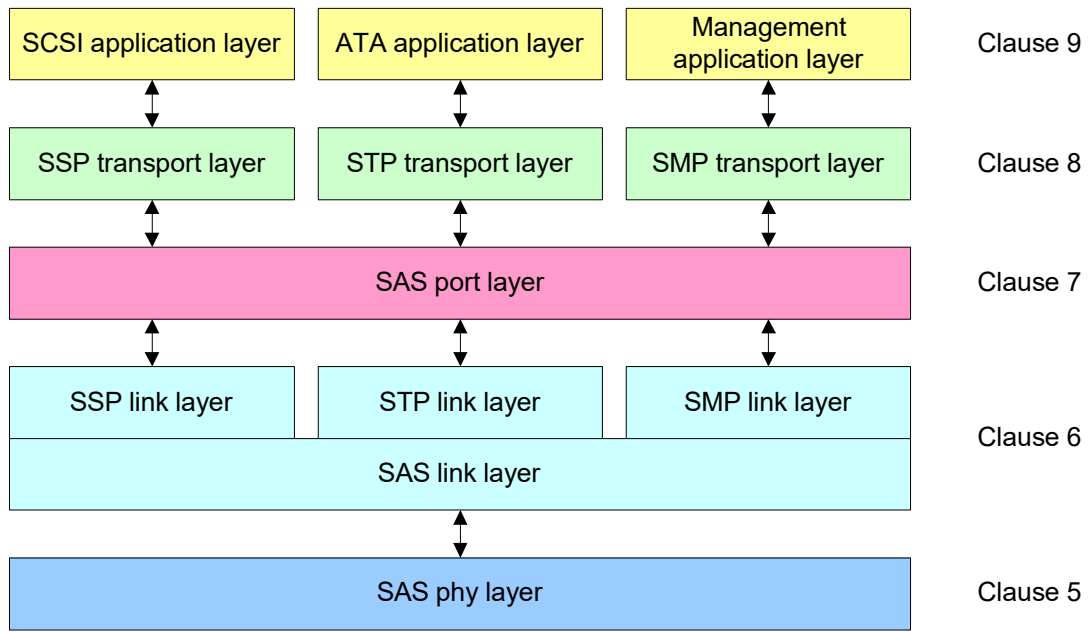

Figure 1 — Organization of this document

This is a preview of "ISO/IEC 14776-263:20...". [Click here to purchase the full version from the ANSI store.](#)

family of standards.

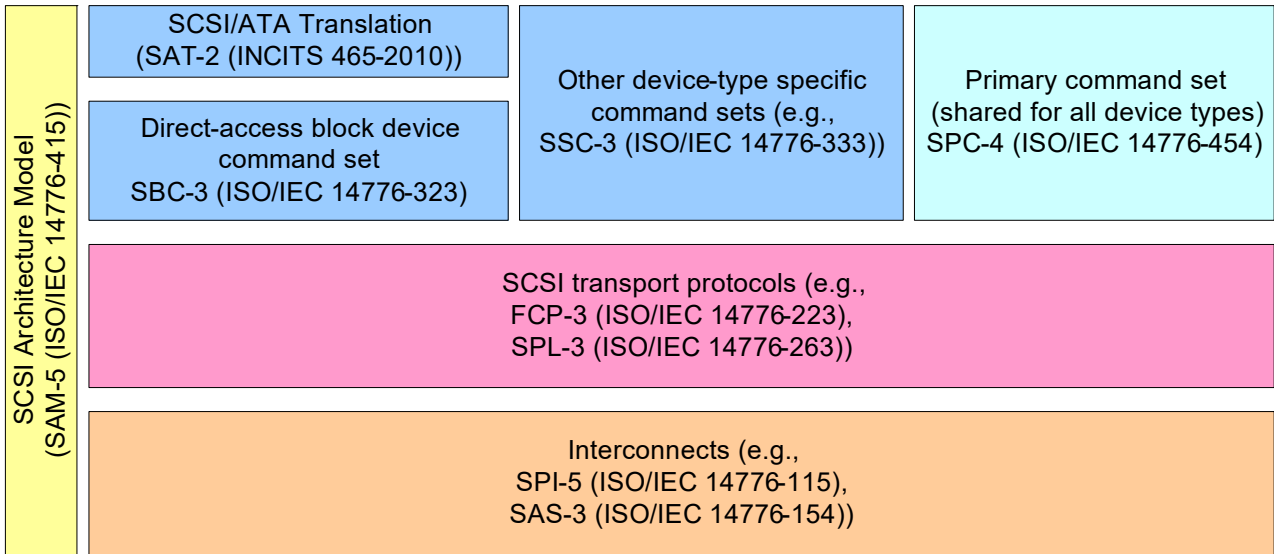

Figure 2 — SCSI document relationships

This document also defines the rules for exchanging information between ATA hosts and ATA devices using the same serial interconnect. Other ATA transport protocol standards define the rules for exchanging information between ATA hosts and ATA devices using other interconnects.

Figure 3 shows the relationship of this document to other standards and related projects in the ATA family of standards.

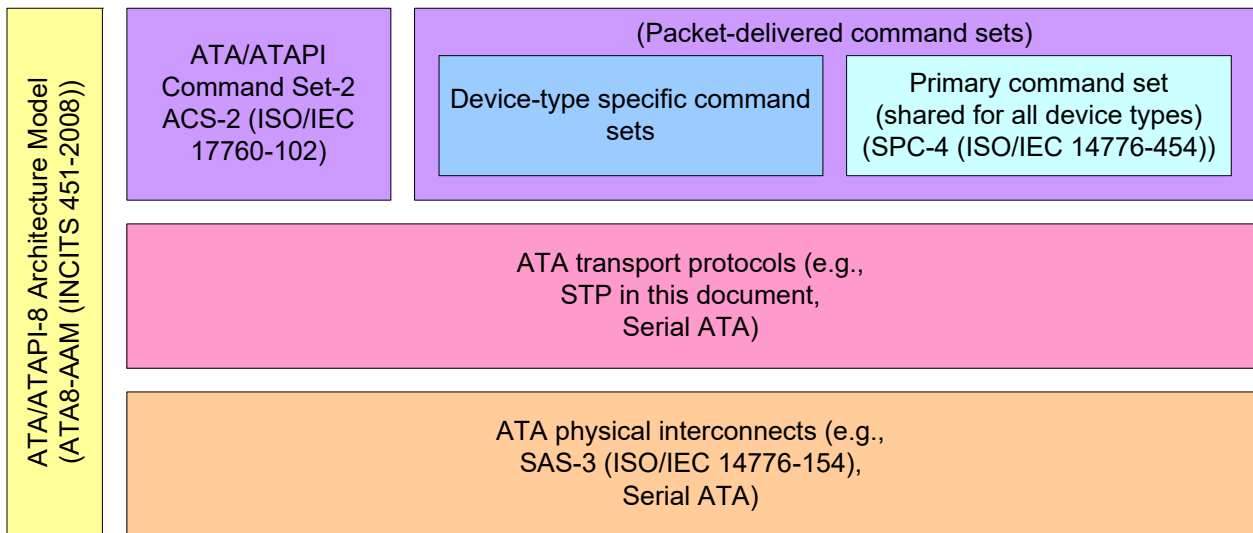

Figure 3 — ATA document relationships

Figure 2 and figure 3 show the general relationship of the documents to one another, and do not imply any hierarchy, protocol stack, or system architecture relationship.

This is a preview of "ISO/IEC 14776-263:20...". [Click here to purchase the full version from the ANSI store.](#)

This is a preview of "ISO/IEC 14776-263:20...". [Click here to purchase the full version from the ANSI store.](#)

Part 263: SAS Protocol Layer - 3 (SPL-3)

1 Scope

This document defines the protocol layer of the Serial Attached SCSI (SAS) interconnect and three transport protocols that use the SAS interconnect:

- a) Serial SCSI Protocol (SSP): a mapping of SCSI supporting multiple initiators and targets;
- b) Serial ATA Tunneled Protocol (STP): a mapping of Serial ATA expanded to support multiple initiators and targets; and
- c) Serial Management Protocol (SMP): a management protocol.

This is a preview of "ISO/IEC 14776-263:20...". Click here to purchase the full version from the ANSI store.

The following documents are referred to in the text in such a way that some or all of their content constitutes requirements of this document. For dated references, only the edition cited applies. For undated references, the latest edition of the referenced document (including any amendments) applies.

Additional availability contact information is provided in Annex L.

ISO/IEC 17760-102, *Information technology - AT Attachment - Part 102: ATA/ATAPI Command Set - 2 (ACS-2)*

ISO/IEC 14776-151, *Information technology - Small Computer System Interface (SCSI) - Part 151: Serial Attached SCSI - 1.1 (SAS-1.1)*

ISO/IEC 14776-323, *Information technology - Small Computer System Interface (SCSI) - Part 323: SCSI Block Commands - 3 (SBC-3)*

ISO/IEC 14776-154, *Information technology - Small Computer System Interface (SCSI) - Part 154: Serial Attached SCSI - 3 (SAS-3)*

ISO/IEC 14776-454, *Information technology - Small Computer System Interface (SCSI) - Part 454: SCSI Primary Commands - 4 (SPC-4)*

INCITS 451-2008, *AT Attachment - 8 ATA/ATAPI Architecture Model (ATA8-AAM)*

INCITS 515, *Information technology - SCSI Architecture Model - 5 (SAM-5)* (planned as ISO/IEC 14776-415)

INCITS 518, *Information technology - SCSI Enclosure Services - 3 (SES-3)* (planned as ISO/IEC 14776-373)

For information on the current status of the listed documents, or regarding availability, contact the indicated organization.

Serial ATA Revision 3.1 (SATA). 18-July-2011 ¹

SFF-8485, *Serial GPIO (SGPIO) Bus* ²

1. Serial ATA specifications are available from the Serial ATA International Organization (see <http://www.sata-io.org>)

2. SFF specifications are available from the SNIA SFF Technology Affiliate (see <http://www.snia.org/sff>).

This is a preview of "ISO/IEC 14776-263:20...". [Click here to purchase the full version from the ANSI store.](#)

Attached SCSI (SAS)

ISO/IEC 9899:1999, *Information technology - Programming languages - C*

ISO 80000-2, *Quantities and units - Part 2: Mathematical signs and symbols to be used in the natural sciences and technology*

INCITS 457-2010, *Information technology - Serial Attached SCSI - 2 (SAS-2)*

INCITS 465-2010, *Information technology - SCSI/ATA Translation - 2 (SAT-2)*

*OMG Unified Modeling Language (UML) Specification. Version 1.5, March 2003*¹

1. For more information on the UML specification, contact the Object Modeling Group (see <http://www.omg.org>)

This is a preview of "ISO/IEC 14776-263:20...". [Click here to purchase the full version from the ANSI store.](#)

This is a preview of "ISO/IEC 14776-263:20...". [Click here to purchase the full version from the ANSI store.](#)

This is a preview of "ISO/IEC 14776-263:20...". Click here to purchase the full version from the ANSI store.

INTERNATIONAL
ELECTROTECHNICAL
COMMISSION

3, rue de Varembé
PO Box 131
CH-1211 Geneva 20
Switzerland

Tel: + 41 22 919 02 11
Fax: + 41 22 919 03 00
info@iec.ch
www.iec.ch