



Approved as an American National Standard
ANSI Approval Date: August 20, 2008

NEMA Standards Publication ANSI/NEMA WD 6-2002 (R2008)

Wiring Devices—Dimensional Specifications

Excerpt: Dimensions for Wiring Devices

Published by

National Electrical Manufacturers Association

1300 North 17th Street
Suite 1752
Rosslyn, Virginia 22209



www.nema.org

EXCERPT
© Copyright 2008 by the National Electrical Manufacturers Association. All rights including translation into other languages, reserved under the Universal Copyright Convention, the Berne Convention for the Protection of Literary and Artistic Works, and the International and Pan American Copyright Conventions.

NOTICE AND DISCLAIMER

The information in this publication was considered technically sound by the consensus of persons engaged in the development and approval of the document at the time it was developed. Consensus does not necessarily mean that there is unanimous agreement among every person participating in the development of this document.

The National Electrical Manufacturers Association (NEMA) standards and guideline publications, of which the document contained herein is one, are developed through a voluntary consensus standards development process. This process brings together volunteers and/or seeks out the views of persons who have an interest in the topic covered by this publication. While NEMA administers the process and establishes rules to promote fairness in the development of consensus, it does not write the document and it does not independently test, evaluate, or verify the accuracy or completeness of any information or the soundness of any judgments contained in its standards and guideline publications.

NEMA disclaims liability for any personal injury, property, or other damages of any nature whatsoever, whether special, indirect, consequential, or compensatory, directly or indirectly resulting from the publication, use of, application, or reliance on this document. NEMA disclaims and makes no guaranty or warranty, expressed or implied, as to the accuracy or completeness of any information published herein, and disclaims and makes no warranty that the information in this document will fulfill any of your particular purposes or needs. NEMA does not undertake to guarantee the performance of any individual manufacturer or seller's products or services by virtue of this standard or guide.

In publishing and making this document available, NEMA is not undertaking to render professional or other services for or on behalf of any person or entity, nor is NEMA undertaking to perform any duty owed by any person or entity to someone else. Anyone using this document should rely on his or her own independent judgment or, as appropriate, seek the advice of a competent professional in determining the exercise of reasonable care in any given circumstances. Information and other standards on the topic covered by this publication may be available from other sources, which the user may wish to consult for additional views or information not covered by this publication.

NEMA has no power, nor does it undertake to police or enforce compliance with the contents of this document. NEMA does not certify, test, or inspect products, designs, or installations for safety or health purposes. Any certification or other statement of compliance with any health or safety-related information in this document shall not be attributable to NEMA and is solely the responsibility of the certifier or maker of the statement.



EXCERPT

CONTENTS

	Page
Foreword.....	ii
Scope.....	.iii
Introduction.....	iv
Wallplate Dimensions.....	1
Yoke Dimensions of Receptacles and Switches for Box Mounting.....	8
Yoke Dimensions for 2 Gang Mounting Receptacles.....	9
Dimensions for Duplex Devices.....	10
Dimensions for Rectangular Face Devices.....	11
Dimensions for Rectangular Face Devices with Protruding Actuators.....	12
Dimensions for Round and Rectangular Face Single Devices.....	13
Dimensions for Interchangeable Type: Single, Duplex, and Triplex Devices.....	14
Wiring Device Maximum Envelope Dimensions.....	15
Dimensions for Flanged Inlets and Connector Bodies.....	16
Flat Blade Hole Locations.....	17



EXCERPT

Foreword

The purpose of these Standards is to present the dimensional requirements of wiring devices in order to assist the user in selecting and obtaining the proper product for a particular need and to minimize the possibility of unsafe interchangeability between configurations.

In the preparation of this Standards Publication, input of users and other interested parties has been sought and evaluated. User input will be formally sought by the canvas procedures of the American National Standards Institute.

The Communications Department has worked closely with the Engineering Department and with individual NEMA Subdivisions in the drafting of this manual and acknowledges the need for periodic review and updating. Proposed or recommended revisions should be submitted to:

Vice President, Technical Services
National Electrical Manufacturers Association
1300 North 17th Street, Suite 1752
Rosslyn, Virginia 22209

Publication ANSI/NEMA WD 6-2002 revises and supersedes NEMA Standards Publication WD 6-1997.



EXCERPT

Scope

These Standards cover dimensional requirements for plugs and receptacles rated up to 60 Ampere and 600 Volts. They also include dimensions for wall plates.

These Standards do not cover performance or other requirements since these are included in NEMA Standards Publication WD 1, *General Requirements for Wiring Devices*.



EXCERPT

Introduction

Throughout this publication the following shall apply:

1. All dimensions are in inches, unless otherwise specified.
2. Decimal dimensions without tolerances shall be subject to a plus or minus 0.005-inch tolerance.
3. Angular dimensions without tolerances shall be subject to a plus or minus 1 degree tolerance.
4. "G" denotes equipment ground.
5. "W" denotes system ground.
6. Leading edges of plug blades shall be free of burrs and sharp edges.
7. All slots and slot tolerances are symmetrically located about centerlines.
8. Female contacts associated with plug blades that are 0.125 minimum longer than other blades are engaged prior to the other female contacts.
9. Configurations utilized on alternating current systems are limited to 50 or 60 Hertz, unless otherwise specified.
10. Dimensions shown in these standards are for the purpose of interchangeability, and do not preclude other designs.
11. The electrical ratings of the configurations in these standards are AC and DC, unless specifically stated 'AC' or 'DC'.



EXCERPT

DIMENSIONAL SPECIFICATIONS FOR WALLPLATES

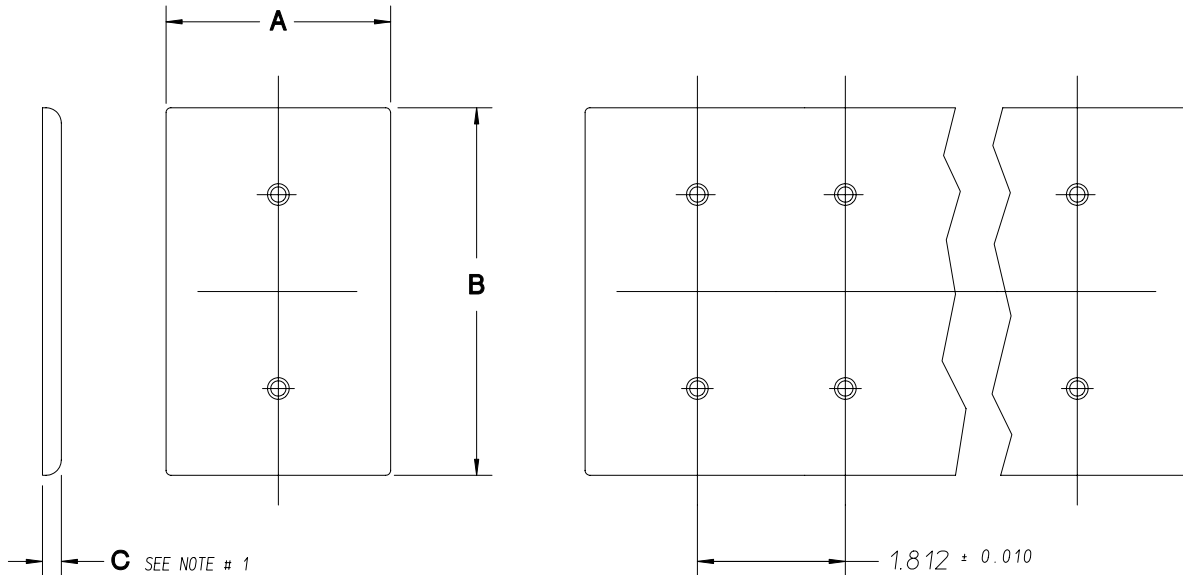

**SINGLE-GANG WALLPLATE
OVERALL DIMENSIONS**

**MULTIGANG WALLPLATE HORIZONTAL HOLE SPACING.
FOR VERTICAL HOLE SPACING SEE PAGE 3.**

REFERENCE	MATERIAL	STANDARD DIMENSIONS	
		MIN	MAX
A	ALL	2.740	—
B	ALL	4.490	—

NOTES:

- 1- THE DEPTH IS DEFINED IN ACCORDANCE TO THE APPLICABLE INSTALLATION CODE BY THE AUTHORITY HAVING JURISDICTION. DECORATIVE CONTOURS SHOULD NOT PRECLUDE THE FLUSH SEATING OF A PLUG INTO A RECEPTACLE.
- 2- PLATE MOUNTING HOLES TO BE COUNTER-SUNK FOR # 6-32 UNC, OVAL HEAD MACHINE SCREW.
- 3- RIBS ARE OPTIONAL ON NON-METALLIC PLATES. HEIGHT, WIDTH, AND LOCATION OF RIBS SHALL CLEAR DEVICE FOR WHICH THE PLATE IS DESIGNED OR INTENDED FOR USE.

**DIMENSIONAL SPECIFICATIONS FOR WALLPLATES
USED ON 347 V SWITCH DEVICES**

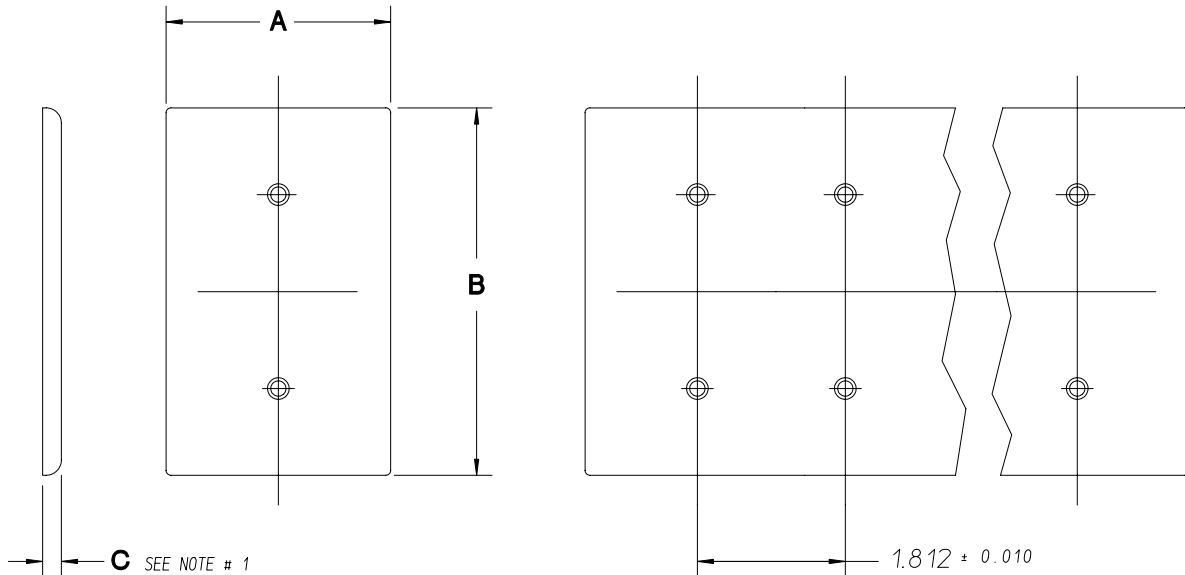

**SINGLE-GANG WALLPLATE
OVERALL DIMENSIONS**

**MULTIGANG WALLPLATE HORIZONTAL HOLE SPACING.
FOR VERTICAL HOLE SPACING SEE PAGE 3.**

REFERENCE	MATERIAL	STANDARD DIMENSIONS	
		MIN	MAX
A	ALL	3.120	—
B	ALL	4.870	—

NOTES:

- 1- THE DEPTH IS DEFINED IN ACCORDANCE TO THE APPLICABLE INSTALLATION CODE BY THE AUTHORITY HAVING JURISDICTION. DECORATIVE CONTOURS SHOULD NOT PRECLUDE THE FLUSH SEATING OF A PLUG INTO A RECEPTACLE.
- 2- PLATE MOUNTING HOLES TO BE COUNTER-SUNK FOR # 6-32 UNC, OVAL HEAD MACHINE SCREW.
- 3- RIBS ARE OPTIONAL ON NON-METALLIC PLATES. HEIGHT, WIDTH, AND LOCATION OF RIBS SHALL CLEAR DEVICE FOR WHICH THE PLATE IS DESIGNED OR INTENDED FOR USE.

MOUNTING AND CUT-OUT DIMENSIONS

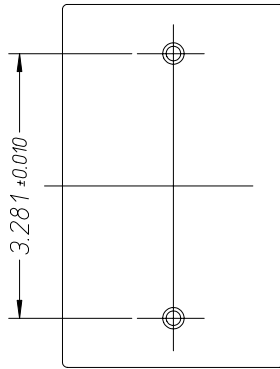

BOX MOUNT BLANK PLATE
(SEE NOTE # 3)

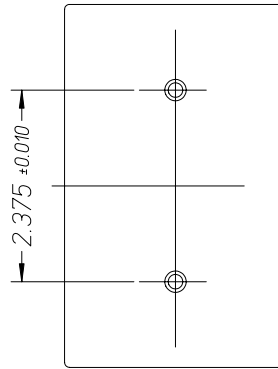

YOKE MOUNT BLANK PLATE
(SEE NOTE # 3)

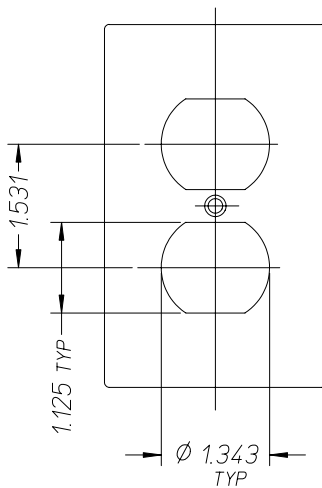

DUPLEX DEVICE

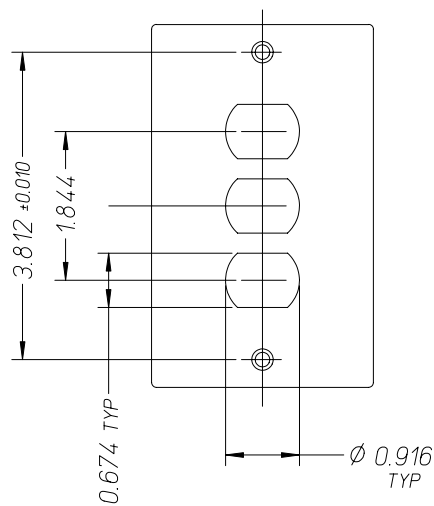

**INTERCHANGEABLE
DEVICE**

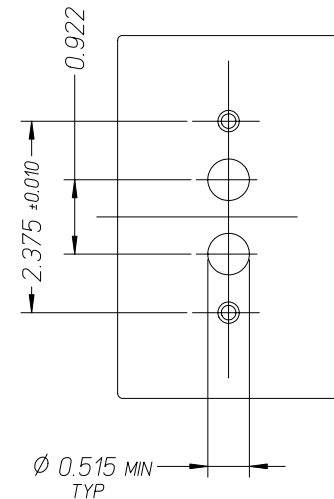

**TWO BUTTON
PUSH SWITCH**

NOTES:

- 1- PLATE MOUNTING HOLES TO BE COUNTER-SUNK FOR # 6-32 UNC, OVAL HEAD MACHINE SCREW.
- 2- RIBS ARE OPTIONAL ON NON-METALLIC PLATES. HEIGHT, WIDTH, AND LOCATION OF RIBS SHALL CLEAR DEVICE FOR WHICH THE PLATE IS DESIGNED OR INTENDED FOR USE.
- 3- BLANK PLATES MAY BE PROVIDED WITH KNOCK-OUTS.

WALLPLATE DIMENSIONS FOR ROUND FACE DEVICES

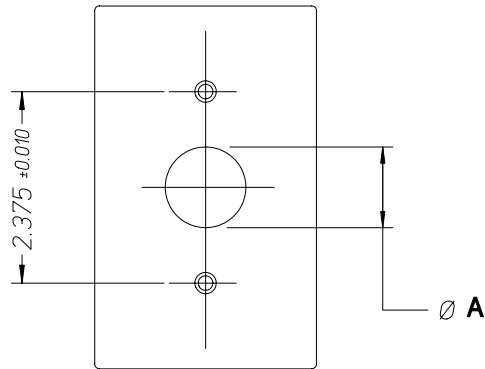

NOMINAL DIAMETER	DEVICE FACE DIAMETER		WALLPLATE OPENING (Ø A)	
	MIN	MAX	MIN	MAX
1	0.968	1.000	1.009	1.025
1 1/8	1.093	1.125	1.134	1.150
1 1/4	1.205	1.235	1.245	1.263
1 3/8	1.360	1.390	1.396	1.414
1 9/16	1.550	1.580	1.586	1.604
1 5/8	1.610	1.640	1.646	1.664
1 11/16	1.675	1.705	1.711	1.729
2 1/8	2.093	2.125	2.140	2.156
2 1/4	2.218	2.250	2.265 *	2.281 *
2 7/16	2.405	2.437	2.452 *	2.468 *

NOTES:

- 1- PLATE MOUNTING HOLES TO BE COUNTER-SUNK FOR # 6-32 UNC, OVAL HEAD MACHINE SCREW.
- 2- RIBS ARE OPTIONAL ON NON-METALLIC PLATES. HEIGHT, WIDTH, AND LOCATION OF RIBS SHALL CLEAR DEVICE FOR WHICH THE PLATE IS DESIGNED OR INTENDED FOR USE.
- 3- DIMENSIONS WITH ASTERISK (*) APPLY TO MULTIGANG PLATES ONLY.

WALLPLATE DIMENSIONS FOR RECTANGULAR FACE DEVICES

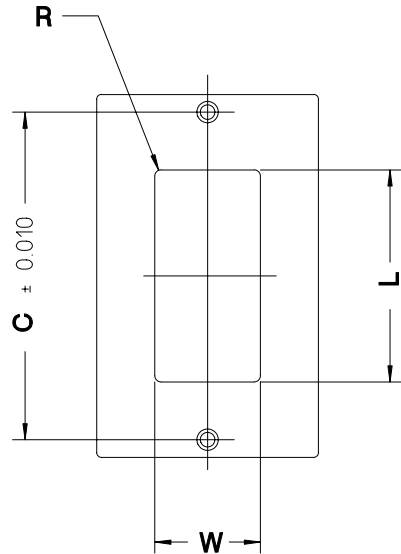

W MIN	L MIN	R	C	APPLICATION (DEVICE FACE)
1.310	2.630	0.079	4.062	1.300 MAX W × 2.620 MAX L (347 V SWITCH)
1.310	2.630	0.094	3.812	1.300 MAX W × 2.620 MAX L

NOTES:

- 1- PLATE MOUNTING HOLES TO BE COUNTER-SUNK FOR # 6-32 UNC, OVAL HEAD MACHINE SCREW.
- 2- RIBS ARE OPTIONAL ON NON-METALLIC PLATES. HEIGHT, WIDTH, AND LOCATION OF RIBS SHALL CLEAR DEVICE FOR WHICH THE PLATE IS DESIGNED OR INTENDED FOR USE.



WALLPLATE DIMENSIONS FOR TELEPHONE DEVICES

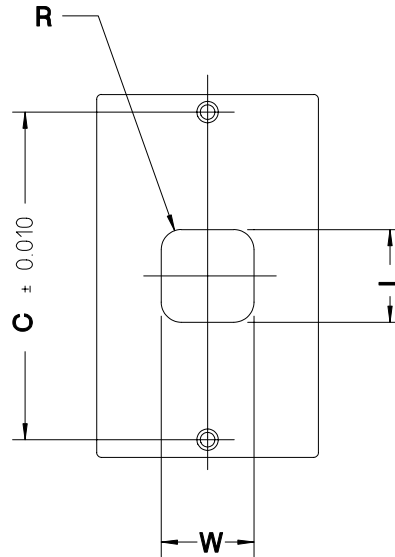

W MIN	L MIN	R	C	APPLICATION (DEVICE FACE)
1.150	1.150	0.250	2.375	1.140 MAX W x 1.140 MAX L

NOTES:

- 1- PLATE MOUNTING HOLES TO BE COUNTER-SUNK FOR # 6-32 UNC, OVAL HEAD MACHINE SCREW.
- 2- RIBS ARE OPTIONAL ON NON-METALLIC PLATES. HEIGHT, WIDTH, AND LOCATION OF RIBS SHALL CLEAR DEVICE FOR WHICH THE PLATE IS DESIGNED OR INTENDED FOR USE.



WALLPLATE DIMENSIONS FOR TOGGLE SWITCH DEVICES

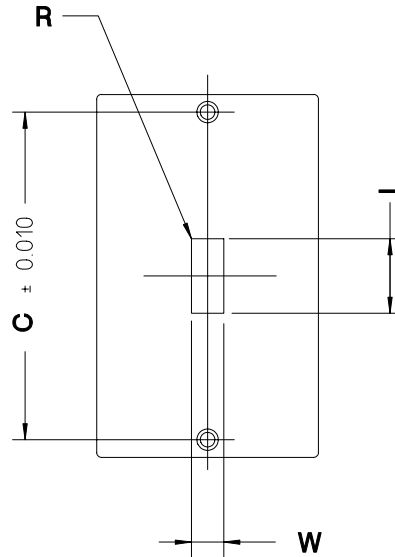

<i>W MIN</i>	<i>L MIN</i>	<i>R</i>	<i>C</i>	<i>APPLICATION</i>
0.401	0.925	0.000	2.375	120 V TO 600 V

NOTES:



- 1- PLATE MOUNTING HOLES TO BE COUNTER-SUNK FOR # 6-32 UNC, OVAL HEAD MACHINE SCREW.
- 2- RIBS ARE OPTIONAL ON NON-METALLIC PLATES. HEIGHT, WIDTH, AND LOCATION OF RIBS SHALL CLEAR DEVICE FOR WHICH THE PLATE IS DESIGNED OR INTENDED FOR USE.

YOKE DIMENSIONS OF RECEPTACLES AND SWITCHES FOR BOX MOUNTING

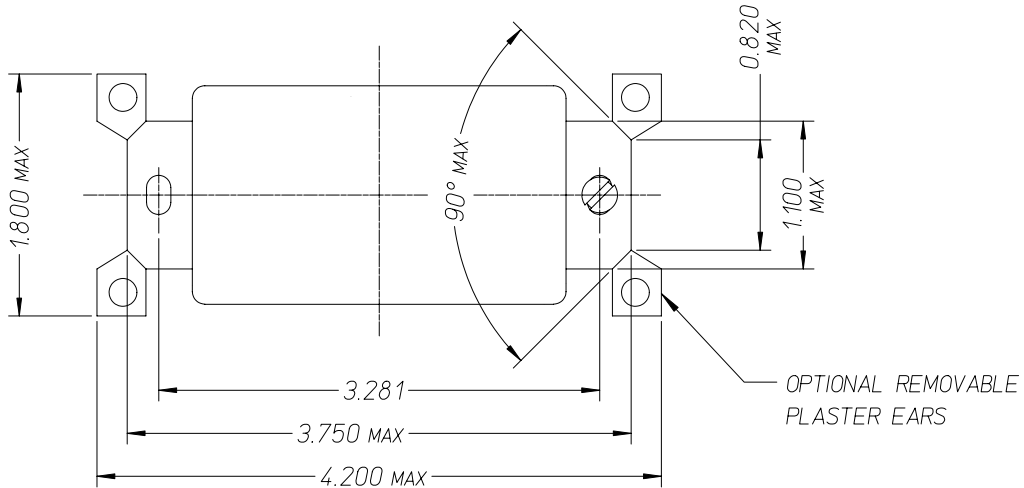

ALTERNATE YOKE CONSTRUCTION

OTHER DIMENSIONS SAME AS ABOVE

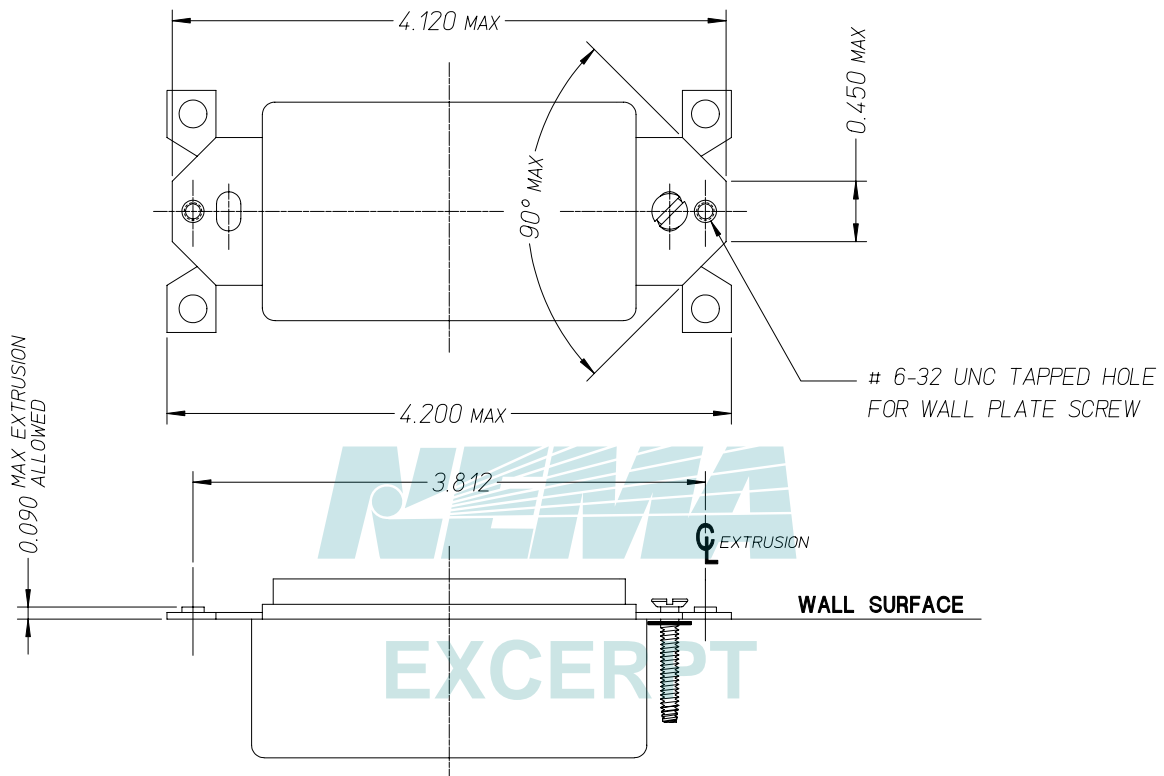

**YOKE DIMENSIONS FOR 2 GANG RECEPTACLE MOUNTING
"OFF-CENTER FACE" TYPE**

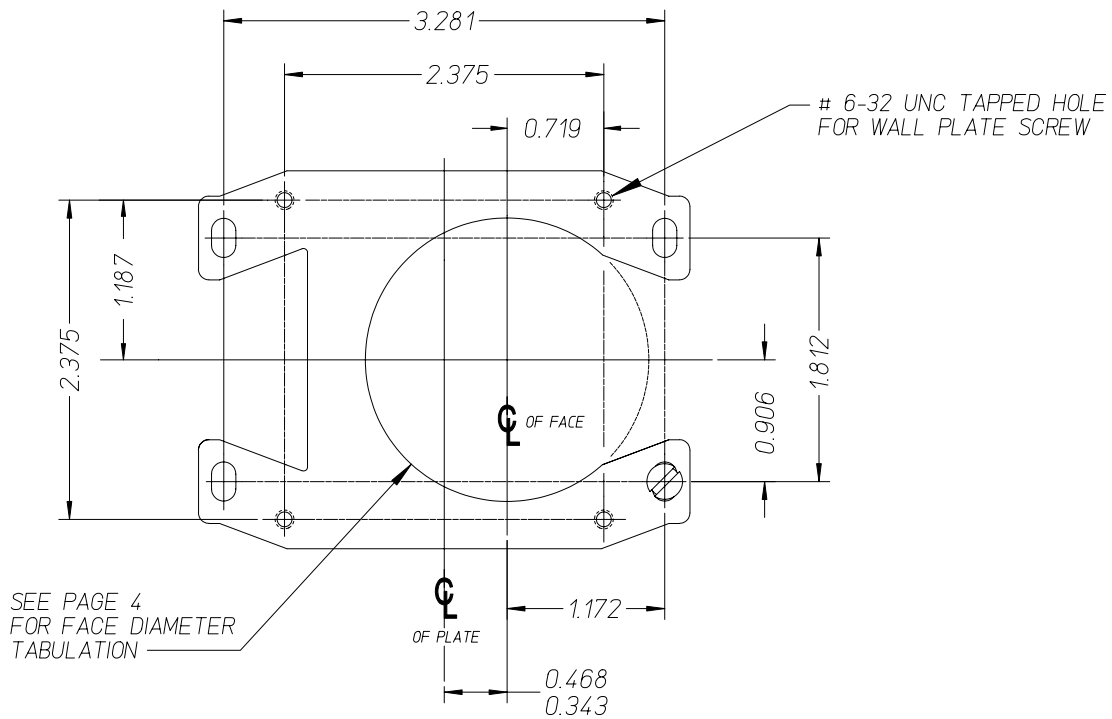

**YOKE DIMENSIONS FOR 2 GANG RECEPTACLE MOUNTING
"ON-CENTER FACE" TYPE**

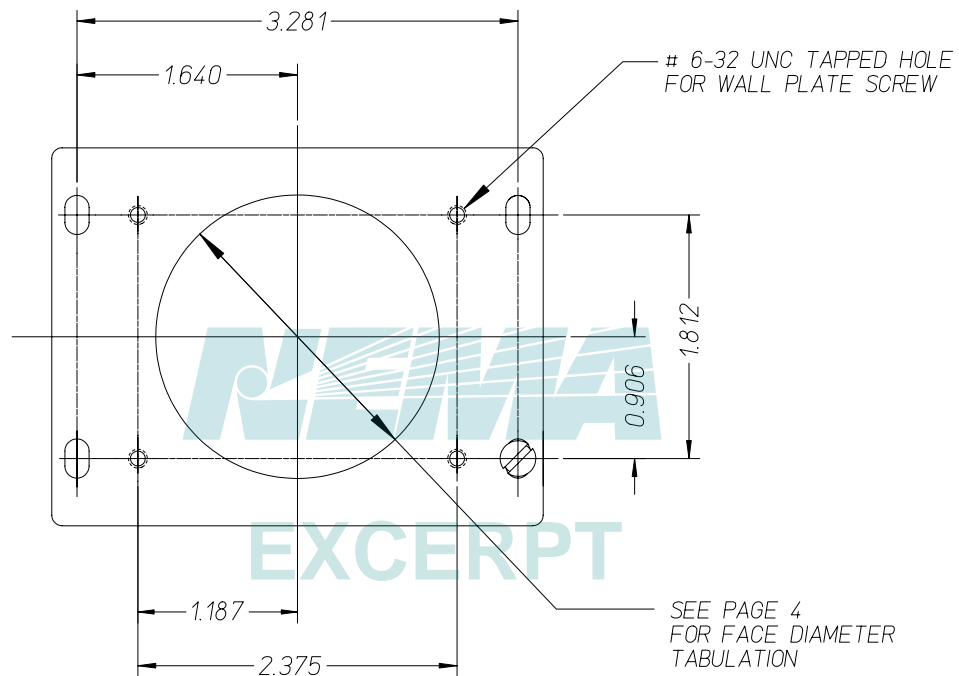

**DIMENSIONS FOR FLUSH MOUNT DUPLEX DEVICES
RECEPTACLES, COMBINATION SWITCHES, ETC...**

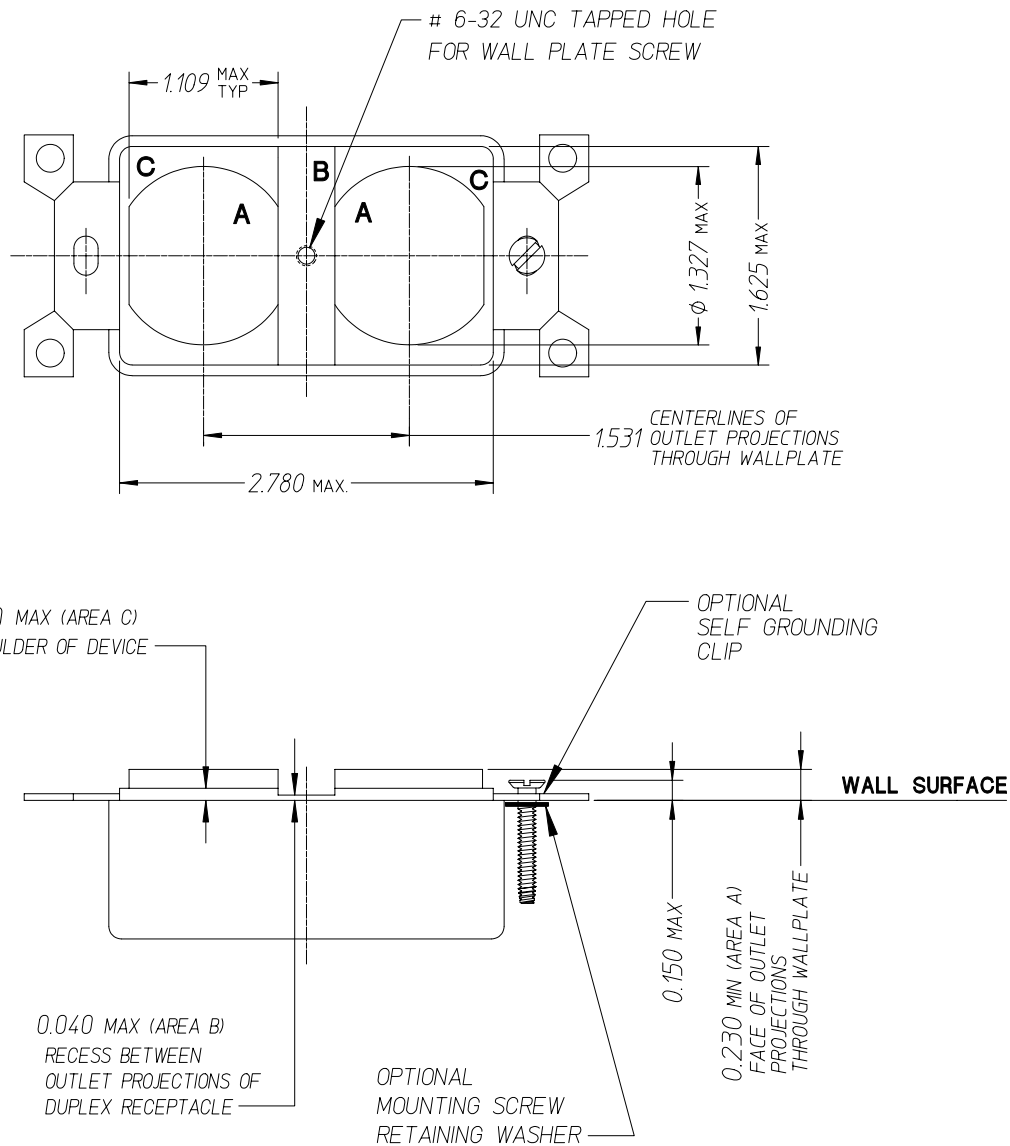

NOTES:

1. SEE PAGE 8 FOR YOKE DIMENSIONS.
2. CENTER LINE SPACING OF DUPLEX OUTLET FACE CONFIGURATIONS LISTED IN NOTE # 3 TO BE 1.531 MIN.
3. TYPICAL DUPLEX RECTANGULAR STYLE CONFIGURATIONS ARE:
1-15, 5-15, 5-20, 6-15, 6-20, 7-15, L1-15, L2-20, L5-15, L6-15, L7-15, L11-15

**DIMENSIONS FOR FLUSH MOUNT RECTANGULAR FACE DEVICES
RECEPTACLES, SWITCHES, EXCLUDING GFCI'S, DIMMERS, MOTION SENSORS, ETC...**

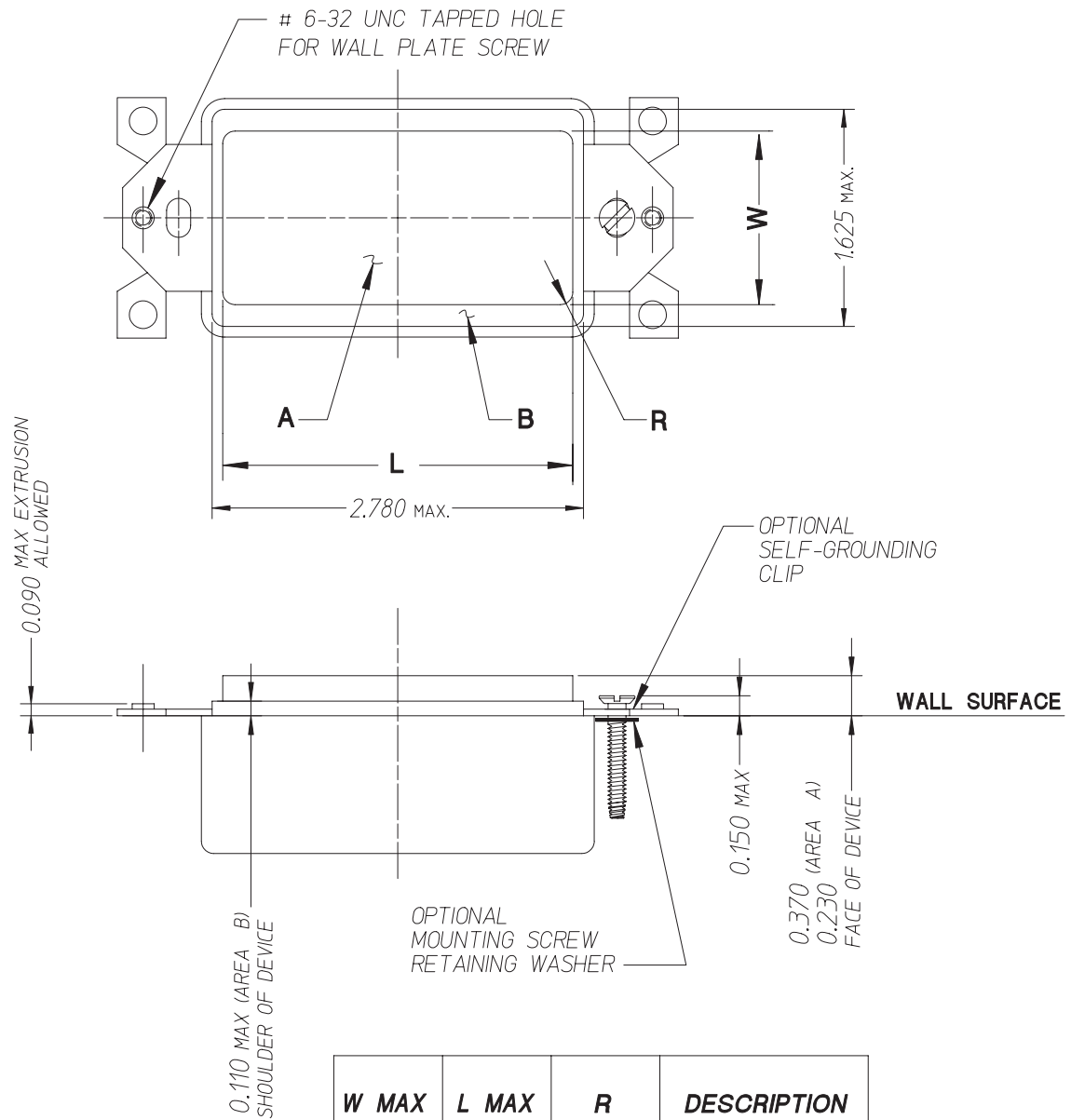

W MAX	L MAX	R	DESCRIPTION
1.300	2.620	0.094	DUPLEX DEVICE
1.060	2.880	0.062	TRIPLEX DEVICE

NOTES:

- SEE PAGE 8 FOR YOKE DIMENSIONS.
- CENTER LINE SPACING OF DUPLEX OUTLET FACE CONFIGURATIONS LISTED IN NOTE # 3 TO BE 1.531 MIN.
- TYPICAL DUPLEX RECTANGULAR STYLE CONFIGURATIONS ARE:
1-15, 5-15, 5-20, 6-15, 6-20, 7-15, L1-15, L2-20, L5-15, L6-15, L7-15, L11-15

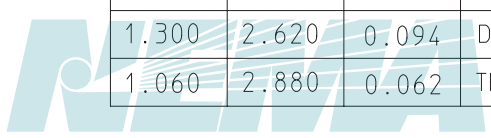

EXCERPT

DIMENSIONS FOR RECTANGULAR FACE DEVICES INCORPORATING PROTRUDING ACTUATORS

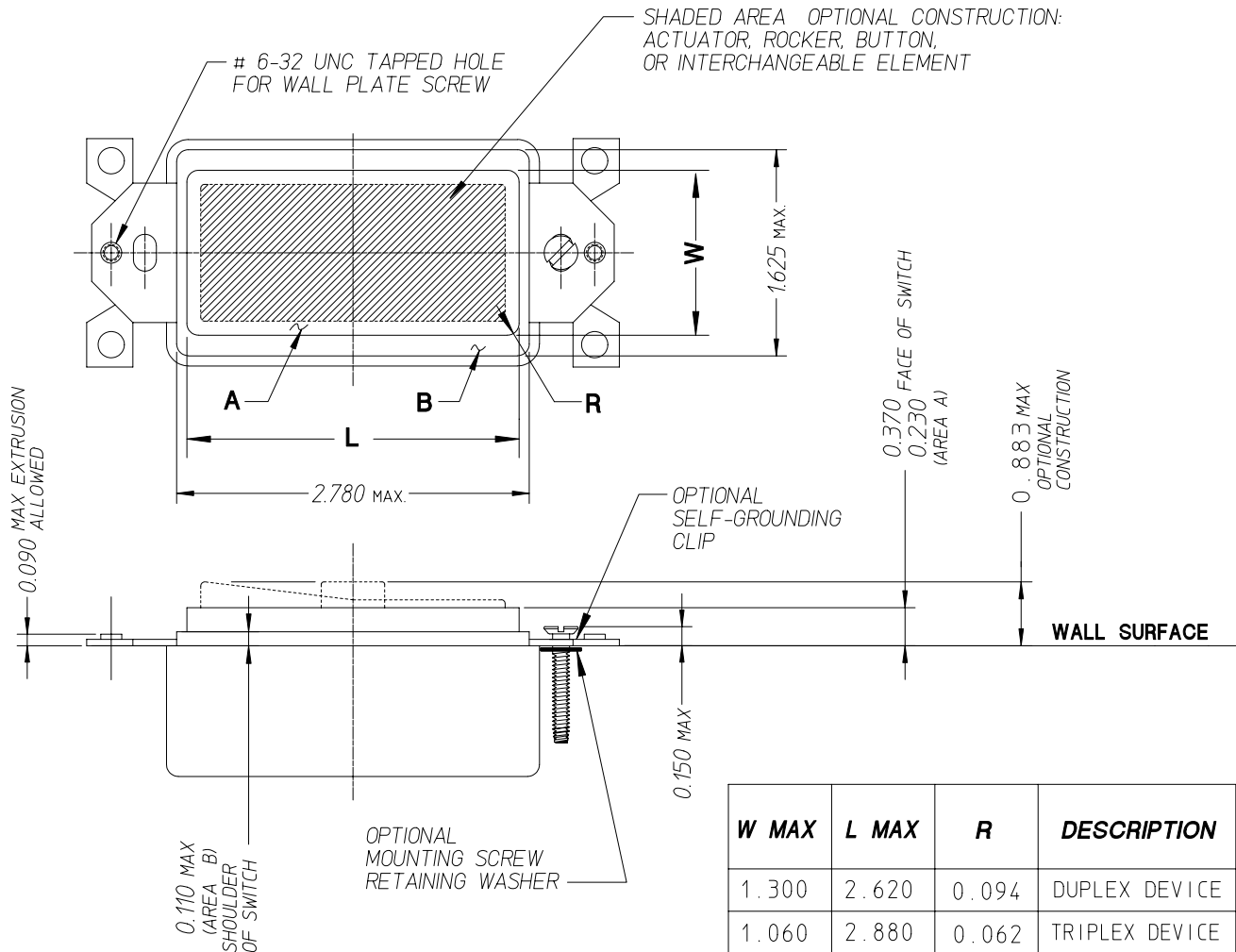

DIMENSIONS FOR RECTANGULAR FACE DEVICES INCORPORATING SWITCH TOGGLES

ALL OTHER DIMENSIONS NOT SHOWN, SEE ABOVE

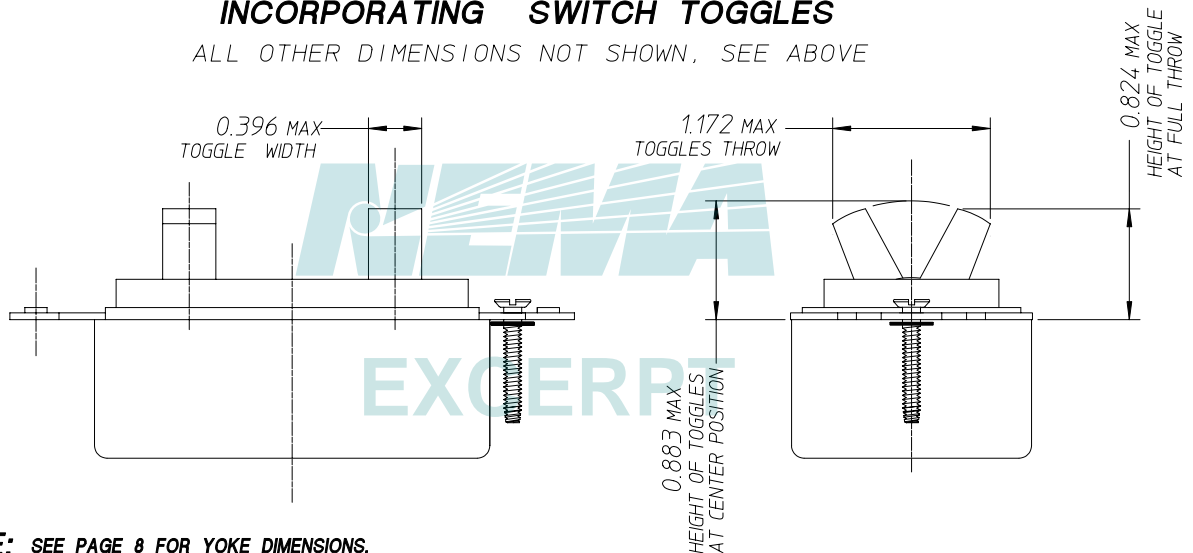

NOTE: SEE PAGE 8 FOR YOKE DIMENSIONS.

**DIMENSIONS FOR ROUND AND RECTANGULAR FACE
SINGLE DEVICES**

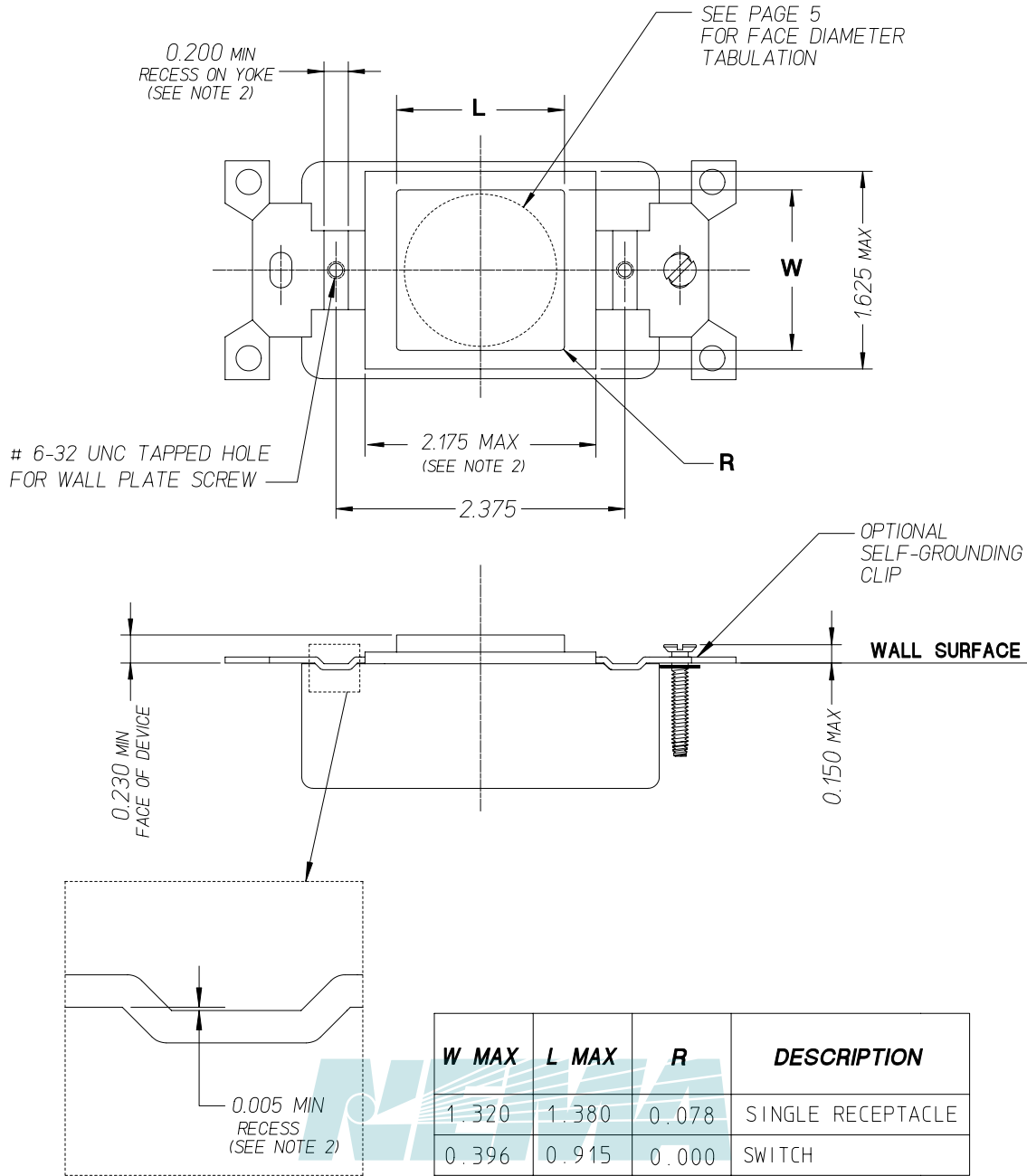

NOTES:

1. SEE PAGE 8 FOR YOKE DIMENSIONS.
2. THIS DIMENSION IS INTENDED FOR STRAIGHT BLADE SINGLE RECEPTACLES AND SWITCHES TO CLEAR THE REINFORCING RIBS IN PLASTIC PLATES

***DIMENSIONS FOR INTERCHANGEABLE TYPE
SINGLE, DUPLEX, AND TRIPLEX DEVICES***

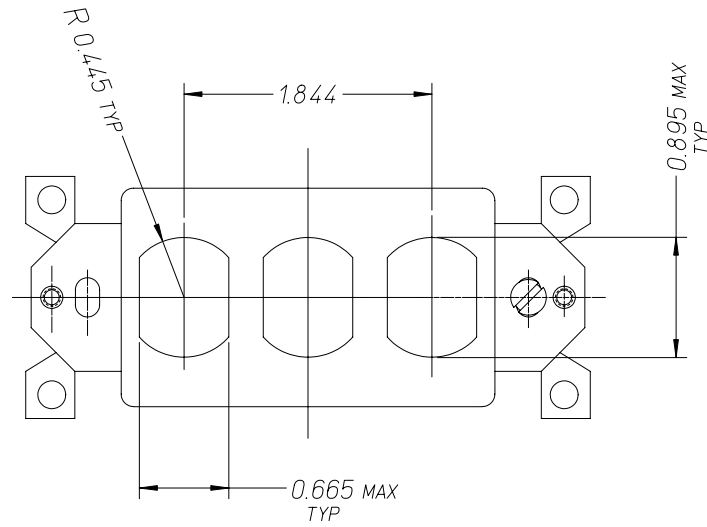

NOTES:

1- SEE PAGE 8 FOR YOKE DIMENSIONS



EXCERPT

WIRING DEVICE MAXIMUM ENVELOPE DIMENSION

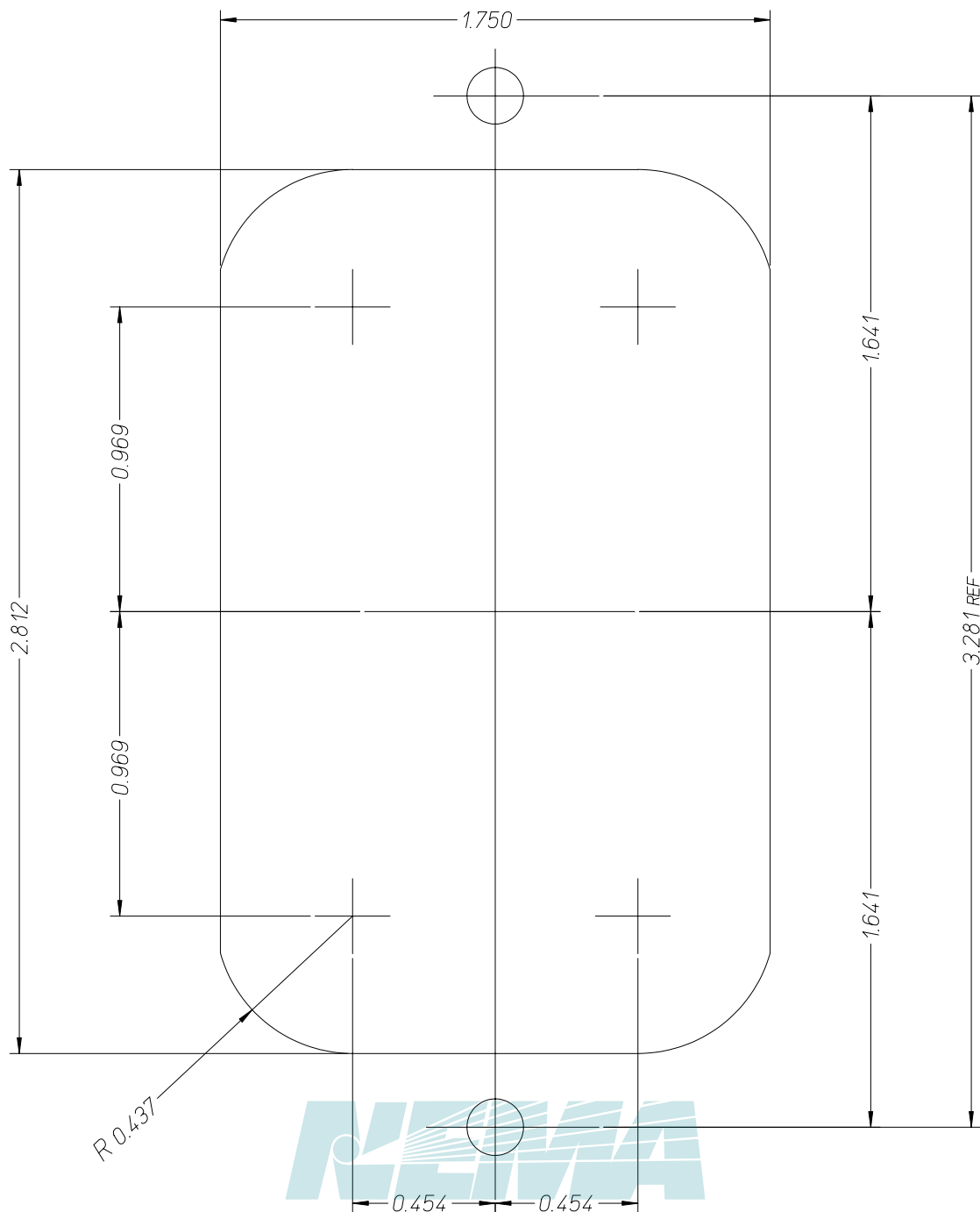

NOTES:

- 1- THIS STANDARD CORRESPONDS TO NEMA STANDARDS PUBLICATION OS-1 SHEET-STEEL OUTLET BOXES, DEVICE BOXES, COVERS AND BOX SUPPORTS, STANDARD FOR MINIMUM BOX/COVER FACE OPENING, AND DOES NOT ADDRESS ELECTRICAL CLEARANCES. AVAILABLE SPACE AT DEPTHS WITHIN THE BOX MAY BE FURTHER REDUCED BY ACCESSORY HARDWARE SUCH AS MACHINE SCREWS, NAILS, CABLE CLAMPS, FIXTURE STUDS, ETC.

DIMENSIONS FOR FLANGED INLETS AND CONNECTOR BODIES.

BLADE DIMENSIONS SHALL CONFORM WITH THE DIMENSIONS FOR PLUG BLADES OF THE SAME RATING AS SHOWN IN INDIVIDUAL CONFIGURATION RATING. THE MALE BASE SHALL ACCEPT A CYLINDER OF DIAMETER 'C' DESCRIBED ABOUT THE CENTER OF THE PLUG CAP CONFIGURATION OF THE SAME RATING FOR A DEPTH NOT LESS THAN DIMENSION 'B'.

THE CONNECTOR BODY SHALL FIT WITHIN A CIRCLE OF DIAMETER 'C' DESCRIBED ABOUT THE CENTER OF THE RECEPTACLE CONFIGURATION OF THE SAME RATING FOR A LENGTH 'D' NOT LESS THAN 0.015 INCH PLUS THE MAXIMUM LENGTH OF DIMENSION 'B'.

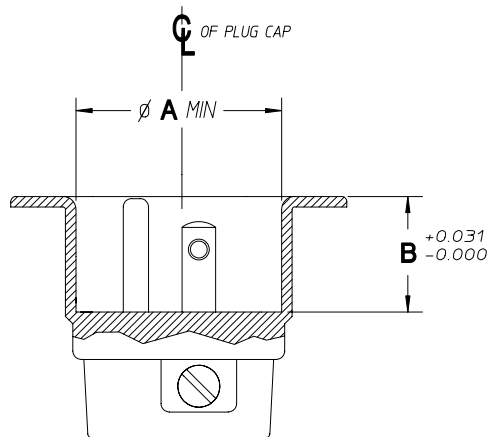

FLANGED INLET

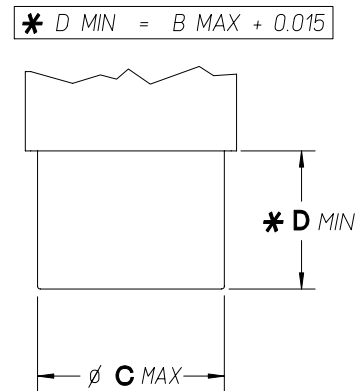

CONNECTOR BODY

CONFIGURATION NUMBER	DIMENSIONS		
	ø A	ø C	B
ML-1	0.990	0.970	0.468
ML-2, ML-3	1.150	1.130	0.468
1-15, 2-15, 5-15, 5-20, 6-15, 6-20, 7-15, 11-15, 11-20, 14-15, 15-15, 18-15, 24-15, 24-20, L1-15, L2-20, L5-15, L6-15, L7-15, L11-15	1.550	1.531	0.843
2-20, 7-20, 10-20, 14-20, 15-20, 18-20	2.030	2.010	0.875
2-30, 5-30, 5-50, 6-30, 6-50, 7-30, 7-50, 10-30, 10-50, 11-30, 11-50, 14-30, 14-50, 14-60, 15-30, 15-50, 15-60, 18-30, 18-50, 18-60, 24-30, 24-50	2.620	2.600	1.406
L5-20, L6-20, L7-20, L8-20, L9-20, L10-20, L11-20, L12-20	1.880	1.860	0.921
L5-30, L6-30, L7-30, L8-30, L9-30, L10-30, L11-30, L12-3, L13-30	1.880	1.860	1.000
L14-20, L15-20, L16-20, L18-20, L19-20, L20-20, L21-20, L22-20, L23-20, L24-20	2.000	1.980	0.921
L14-30, L15-30, L16-30, L17-30, L18-30, L19-30, L20-30, L21-30, L22-30, L23-30	2.000	1.980	1.000

FLAT BLADE HOLE LOCATIONS GENERAL INFORMATION

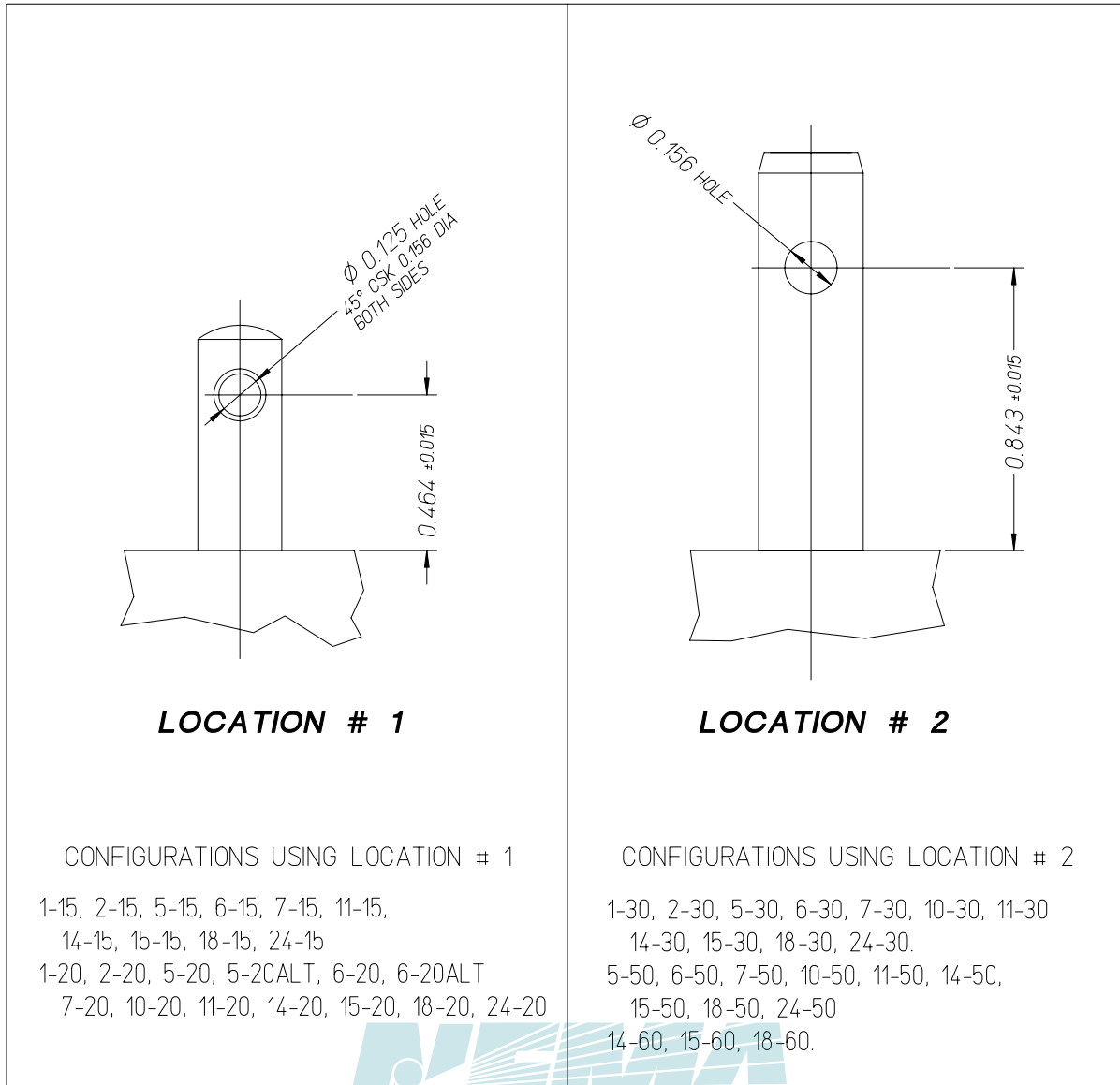

NOTES:

1- HOLE IN FLAT BLADE IS OPTIONAL, AND IT IS INTENDED FOR MANUFACTURING PURPOSES ONLY.
HOWEVER IF USED IT MUST BE LOCATED AS PER DIMENSIONS SHOWN ABOVE.